

radicon

with you at every turn

Series M Helical In-Line

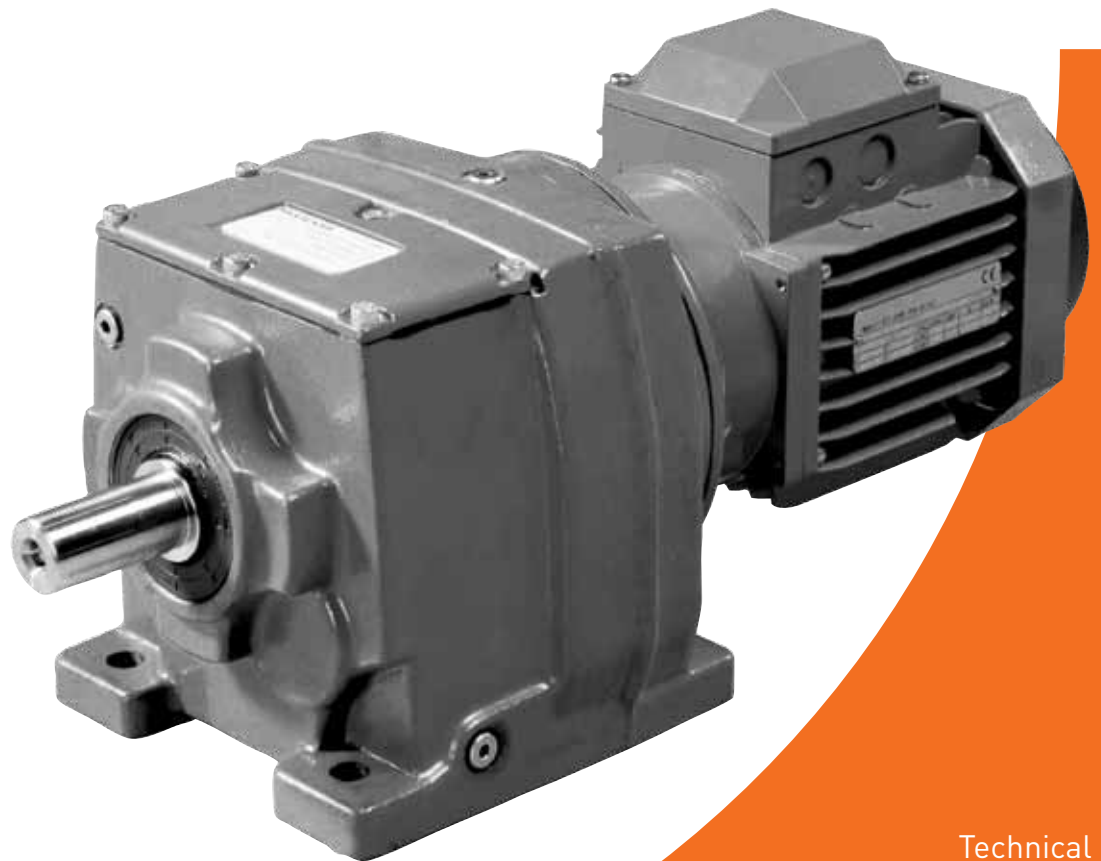

Technical
Up to - 90kW / 11,000 Nm

Geared Motors
CM-2.00GB1211

PRODUCTS IN THE RANGE

Serving an entire spectrum of mechanical drive applications from food, energy, mining and metal; to automotive, aerospace and marine propulsion, we are here to make a positive difference to the supply of drive solutions.

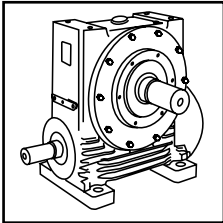

Series A
Worm Gear units
and geared motors
in single & double
reduction types

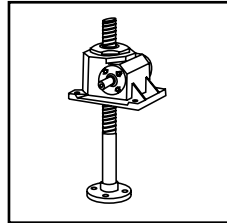

Series BD
Screwjack worm
gear unit

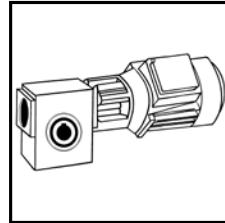

Series BS
Worm gear unit

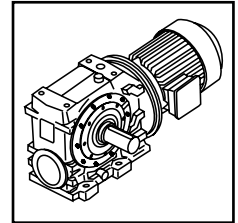

Series C
Right angle drive
helical worm geared
motors & reducers

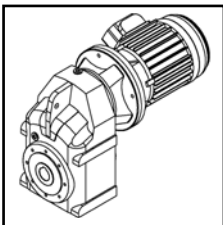

Series F
Parallel angle helical
bevel helical geared
motors & reducers

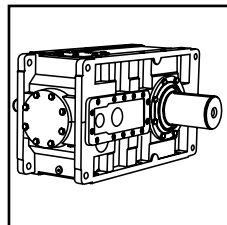

Series G
Helical parallel shaft
& bevel helical right
angle drive gear
units

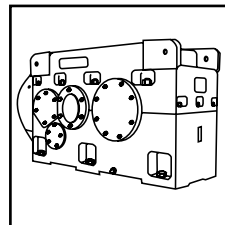

Series H
Large helical parallel
shaft & bevel helical
right angle drive units

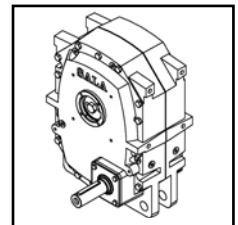

Series J
Shaft mounted
helical speed
reducers

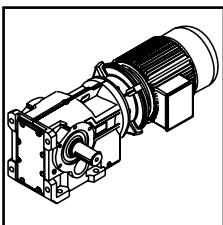

Series K
Right angle helical
bevel helical geared
motors & reducers

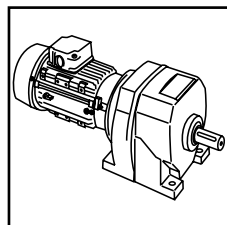

Series M
In-line helical geared
motors & reducers

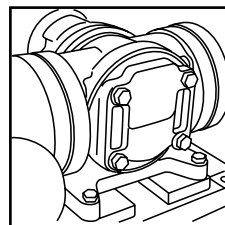

Roloid Gear Pump
Lubrication and fluid
transportation pump

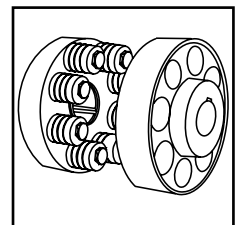

**Series X
Cone Ring**
Pin and bush
elastomer coupling

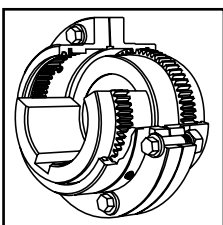

**Series X
Gear**
Torsionally rigid,
high torque coupling

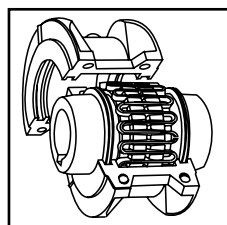

**Series X
Grid**
Double flexing steel
grid coupling

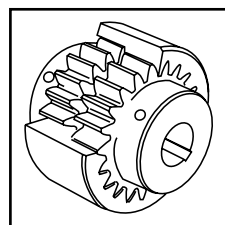

**Series X
Nylon**
Gear coupling with
nylon sleeve

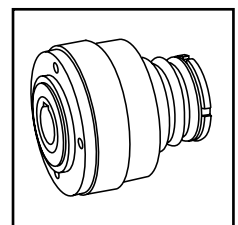

**Series X
Torque Limiter**
Overload protection
device



We offer a wide range of repair services and many years experience of repairing demanding and highly critical transmissions in numerous industries.

We can create custom engineered transmission solutions of any size and configuration.

ATEX Compliance Assured



Total compliance with the ATEX Directive safeguarding the use of industrial equipment in potentially explosive atmospheres is assured for users of our geared products.

Certification is available for standard gearboxes and geared motors with badging displaying the CE Mark and the Ex mark, name and location of the manufacturer, designation of series or type, serial number, year of manufacture, Ex symbol and equipment group/category.

ATEX directive 94/9/EC (also known as ATEX 95 or ATEX 100A) and the CE Marking Directive are enforced in all EC member states. Compliance is compulsory for designers, manufacturers or suppliers of electrical and non-electrical equipment for use in potentially explosive atmospheres created by the presence of flammable gases, vapours, mists or dusts.

Ex compliant standard gearboxes can be supplied against Groups 2 or 3 for surface industries in designated hazardous location Zones 1 and 2 for gases, vapours and mists; and in Zones 21 and 22 for dusts.

SERIES M

NOTES

SERIES M

CONTENTS

General Description _____	1
Unit Designations _____	2
Explanation and use of Ratings and Service Factors _____	3
Load Classification by Applications _____	4
Selection Procedure _____	5 - 6
Unit Versions - Column 9 Entry _____	7
Output Shaft Options - Column 11 Entry _____	8
Motor Adaptors - Column 12 Entry _____	9 - 12
Lubrication _____	13
Mounting Positions - Column 13 and 14 Entry _____	14
MOTORISED	
Motor Performance Data _____	17
Motor Details _____	18
Additional Motor Features - Column 19 Entry _____	19
Additional Gearbox Features - Column 20 Entry _____	20
Selection Tables - Geared Motors _____	21 - 73
Dimension Sheets - Geared Motors _____	74 - 81
Motorised Backstop Module _____	82
REDUCER	
Overhung & Axial Loads on Shafts _____	85 - 86
Ratings - Input Power / Output Torque _____	87 - 97
Dimension Sheets - Speed Reducers _____	98 - 105
C-Flange (B14) Mounting Dimensions _____	106
Thermal Power Ratings / Dimensions of Units with Fans _____	107 - 108
Reducer Backstop Module _____	109
Shipping Specification _____	110 - 111

SERIES M

GENERAL DESCRIPTION

Series M inline geared motors and reducers provide a very efficient and compact drive solution to meet most requirements up to 90kW with maximum output torque capacity of 11000Nm.

The range takes advantage of many years of accumulated design expertise, together with the use of high quality materials and components. The end result is a series of speed reducing and geared motors offering high load carrying capacity, high efficiency, quiet running and reliability.

The Range Includes

Twelve sizes of unit with a ratio coverage of 1.4/1 to 70/1 in double reduction and up to 250/1 in triple reduction and 16200/1 in combined units.

Unit Versions Available

- Base Mounted
- B5 (D) Flange Mounted
- B14 (C) Flange Mounting
- Base Mount and B14 (C) Flange Mounting

Unit type M - Motorised with IEC standard motor

Unit type N - Motorised with NEMA standard motor

Unit type H - Motorised with IEC high efficiency motor (IE2 or EPACT)

Unit type E - Motorised with NEMA high efficiency motor (EPACT)

Unit type G - Unit to allow fitting of a standard IEC motor

Unit type A - Unit to allow fitting of NEMA motor

Unit type R - Reducer unit

Unit type S - Reducer unit with fan kit

Unit type W - Reducer unit with backstop CCW rotation

Unit type X - Reducer unit with backstop CW rotation

Unit type Y - Reducer unit with fan and backstop CW rotation

Unit type Z - Reducer unit with fan and backstop CCW rotation

Design Features Include

Patented standard motor connection (IEC or NEMA).

Ability to fit double oil seal input and output as required.

All units being suitable to fit IEC or NEMA standard motors.

All units are dimensionally interchangeable with other major manufacturers.

Brake geared motors are available as standard.

Sizes 01, 02, 03, 04, 05, 06 and 07 are all supplied with lubricant.

Sizes 08, 09, 10, 13 and 14 are supplied without lubricant.

Motorised units can be fitted with a backstop module and reducer units can be fitted with a backstop and fan.

As improvements in design are being made continually this specification is not to be regarded as binding in detail and drawings and capacities are subject to alteration without notice. Certified drawings will be sent on request.

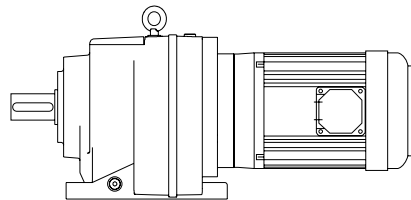

Two stage base mounted motorised

*

M	0	3	2	2	8	.	0	B	M	C	-	1	A	.	7	5	A	-	-
---	---	---	---	---	---	---	---	---	---	---	---	---	---	---	---	---	---	---	---

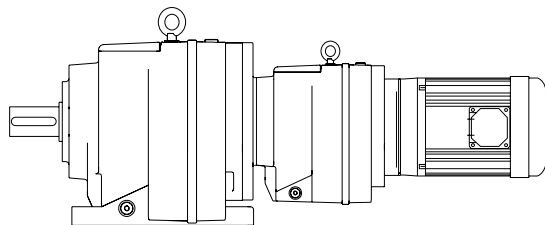

Four stage base mounted motorised

*

M	0	6	4	2	2	5	0	B	M	C	-	1	A	.	1	8	A	-	-
---	---	---	---	---	---	---	---	---	---	---	---	---	---	---	---	---	---	---	---

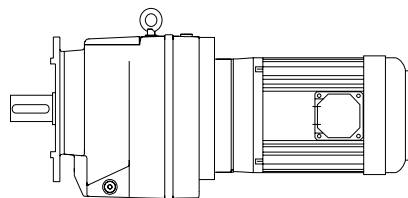

Three stage flange mounted motorised

*

M	0	6	3	2	1	2	5	L	M	C	-	1	A	.	7	5	A	-	-
---	---	---	---	---	---	---	---	---	---	---	---	---	---	---	---	---	---	---	---

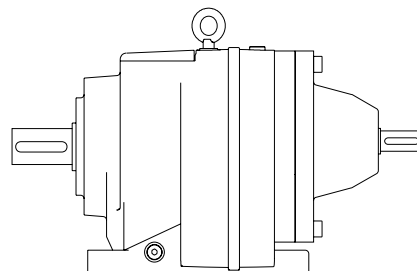

Two stage base mounted reducer

*

M	0	7	2	2	7	1	.	B	R	C	-	1	-	-	-	-	-	-	-
---	---	---	---	---	---	---	---	---	---	---	---	---	---	---	---	---	---	---	---

* Typical unit designations

UNIT DESIGNATIONS

Gearbox Codes													Motor Codes							
Series	Size of Unit		No of Reductions	Revision Version	Nominal Overall Ratio			Unit Version	Type of Unit	Output Shaft	Motor Adaptor	Mounting Position	Geared Motor Power			No of Motor Poles	Additional Motor Features	Additional Gearbox Features		
1	2	3	4	5	6	7	8	9	10	11	12	13	14	15	16	17	18	19	20	
M																				
M	0	3	2	2	8	.	0	B	M	C	-	1	A	.	7	5	A	-	-	

*

Example

1 - Series M

Range

2, 3 - Size of Unit

Through

4 - No of Reductions

Through

5 - Revision Version

6, 7, 8 - Nominal Overall Ratio

eg

9 - Unit Version

- Base Mounted
 - B14 (C) Flange Mounting
 - Base and B14 (C) Flange Mounting
- (Non - Standard Special Orders Only)
- Letter Entry Depends on Flange Diameter

10 - Type of Unit

- Motorised with IE2 standard motor
- Motorised with EPACT standard motor
- Motorised with IEC high efficiency motor (IE3)
- Motorised with NEMA high efficiency motor (PREMIUM)
- Unit to allow fitting of IEC motor (customer own motor)
- Unit to allow fitting of NEMA motor (customer own motor)
- Reducer unit
- Reducer unit with fan kit
- Reducer unit with backstop CCW rotation
- Reducer unit with backstop CW rotation
- Reducer unit with fan and backstop CW rotation
- Reducer unit with fan and backstop CCW rotation

20 - Additional Gearbox Features

Double Oil Seal, Motorised Backstop Etc

eg

19 - Additional Motor Features

eg

For Types Without Motor

Enter

18 - No of Motor Poles

No motor

		50 Hz		60 Hz
4 Pole (Std)	1500 rpm	<input type="text" value="A"/>	1800 rpm	<input type="text" value="B"/>
4 Pole (High)	1500 rpm	<input type="text" value="K"/>	1800 rpm	<input type="text" value="L"/>
6 Pole (Std)	1000 rpm	<input type="text" value="C"/>	1200 rpm	<input type="text" value="D"/>
6 Pole (High)	1000 rpm	<input type="text" value="M"/>	1200 rpm	<input type="text" value="N"/>
2 Pole	3000 rpm	<input type="text" value="E"/>	3600 rpm	<input type="text" value="F"/>
8 Pole	750 rpm	<input type="text" value="G"/>	900 rpm	<input type="text" value="H"/>

Dual speed or special motor

15, 16, 17 - Geared Motor Powers

Motor Power Required

eg

For reducer and non standard

motor types enter

13, 14 - Mounting Position

eg

12 - Motor Adaptor For Unit Types

Column 10 Entries M, N, H, E, G or A

For All Other Types Enter

11 - Output Shaft

- Standard

- Inch

SERIES M

EXPLANATION & USE OF RATINGS & SERVICE FACTORS

Gear unit selection is made by comparing actual loads with catalogue ratings. Catalogue ratings are based on a standard set of loading conditions, whereas actual load conditions vary according to type of application. Service Factors are therefore used to calculate an equivalent load to compare with catalogue ratings.

i.e. Equivalent Load = Actual Load x Service Factor

Mechanical ratings and service factors Fm and Fs

Mechanical ratings measure capacity in terms of life and/or strength, assuming 10 hr/day continuous running under uniform load conditions.

Catalogue ratings allow 100% overload at starting, braking or momentarily during operation up to 10 hours per day.

The unit selected must therefore have a catalogue rating at least equal to half maximum overload.

Mechanical Service Factor Fm (Table 1) is used to modify the actual load according to daily operating time, and type of loading.

Load characteristics for a wide range of applications are detailed in Table 3 opposite, which are used in deciding the appropriate Service Factor Fm from Table 1.

If overloads can be calculated, or accurately assessed, actual loads should be used instead of Fm.

For units subjected to frequent stop/starts overloads in excess of 10 times/day multiply factor Fm x Factor Fs (table 2).

For applications where units are to operate in extremely dusty or moist/humid atmospheres unit selection should be referred to our application engineers.

Table 1. Mechanical Service Factor (Fm)

Prime mover	Duration of service-hrs per day	Load classification-driven machine		
		Uniform mass acceleration factor ≤ 0.2	Moderate mass acceleration factor ≤ 3	Heavy mass acceleration factor ≤ 10
Electric motor, steam turbine or hydraulic motor	Under 3	0.80	1.00	1.50
	3 to 10	1.00	1.25	1.75
	Over 10	1.25	1.50	2.00
Multi-cylinder internal combustion engine	Under 3	1.00	1.25	1.75
	3 to 10	1.25	1.50	2.00
	Over 10	1.50	1.75	2.25
Single cylinder internal combustion engine	Under 3	1.25	1.50	2.00
	3 to 10	1.50	1.75	2.25
	Over 10	1.75	2.00	2.50

$$\text{Mass acceleration factor} = \frac{\text{all external moments of inertia}^*}{\text{moment of inertia of driving motor}}$$

* calculated with reference to the motor speed

Table 2. Number of Starts Factor (Fs)

Start / Stops per hour (1)	Up to 1	5	10	40	60	≥ 200
Factor Fs	1.00	1.03	1.06	1.10	1.15	1.20

Note: (1) Intermediate values are obtained by linear interpolation

SERIES M

LOAD CLASSIFICATION BY APPLICATIONS

Table 3

U = Uniform load

M = Moderate shock load

H = Heavy shock load

† = Refer to Application Engineering

Driven Machine	type of load	Driven Machine	type of load	Driven Machine	type of load
Agitators		Cranes		log haul	H
pure liquids	U	main hoists	†	presses	M
liquids and solids	M	bridge travel	†	pulp machine reel	M
liquids-variable density	M	trolley travel	†	stock chest	M
Blowers		Crusher		suction roll	M
centrifugal	U	ore	H	washers and thickeners	M
lobe	M	stone	H	winders	M
vane	U	sugar	H	Printing presses	†
Brewing and distilling		Dredges		Pullers	
bottling machinery	M	cable reels	M	barge haul	H
brew kettles-continuous duty	M	conveyors	M	Pumps	
cookers-continuous duty	M	cutter head drives	H	centrifugal	U
mash tubs-continuous duty	M	jig drives	H	proportioning	M
scale hopper-frequent starts	M	manoeuvring winches	M	reciprocating	
Can filling machines	M	pumps	M	single acting; 3 or more cylinders	M
Cane knives	M	screen drive	H	double acting; 2 or more cylinders	M
Car dumpers	H	stackers	M	single acting; 1 or 2 cylinders	†
Car pullers	M	utility winches	M	double acting; single cylinder	†
Clarifiers	U	Dry dock cranes		rotary	
Classifiers	M	main hoist	†	gear type	U
Clay working machinery		auxiliary hoist	†	lobe, vane	U
brick press	H	boom, luffing	†	Rubber and plastics industries	
briquette machine	H	rotating, swing or slew tracking, drive wheels	†	crackers	H
clay working machinery	M	Elevators		laboratory equipment	M
pug mill	M	bucket-uniform load	U	mixed mills	H
Compressors		bucket-heavy load	M	refiners	M
centrifugal	U	bucket-continuous	U	rubber calenders	M
lobe	M	centrifugal discharge	U	rubber mill-2 on line	M
reciprocating		escalators	U	rubber mill-3 on line	M
multi-cylinder	M	freight	U	sheeter	M
single cylinder	H	gravity discharge	†	tire building machines	†
Conveyors-uniformly loaded or fed		man lifts	†	tire and tube press	†
apron	U	passenger	†	openers	†
assembly	U	Fans		tubers and strainers	M
belt	U	centrifugal	U	warming mills	M
bucket	U	cooling towers		Sand muller	M
chain	U	induced draft	†	Sewage disposal equipment	
flight	U	forced draft	†	bar screens	U
oven	U	induced draft	M	chemical feeders	U
screw	U	large, mine, etc	M	collectors	U
Conveyors-heavy duty not uniformly fed		large, industrial	M	dewatering screws	M
apron	M	light, small diameter	U	scum breakers	M
assembly	M	Feeders		slow or rapid mixers	M
belt	M	apron	M	thickeners	M
bucket	M	belt	U	vacuum filters	M
chain	M	disc	M	Screens	
flight	M	reciprocating	H	air washing	U
live roll	†	screw	M	rotary-stone or gravel	M
oven	†	Food industry		travelling water intake	U
reciprocating	H	beef slicer	M	Slab pushers	M
screw	M	cereal cooker	U	Steering gear	†
shaker	H	dough mixer	M	Stokers	U
		meat grinders	M	Sugar industry	
		Generators-not welding	U	cane knives	M
		Hammer mills	H	crushers	M
		Hoists		mills	M
		heavy duty	H	Textile industry	
		medium duty	M	batchers	M
		skip hoist	M	calenders	M
		Laundry washers		cards	M
		reversing	M	dry cans	M
		Laundry tumblers	M	dryers	M
		Line shafts		dyeing machinery	†
		driving processing equipment	M	knitting machines	†
		light	U	looms	M
		other line shafts	U	mangles	M
		Lumber industry		nappers	M
		barkers-hydraulic-mechanical	M	pads	†
		burner conveyor	M	range drives	†
		chain saw and drag saw	H	slashers	M
		chain transfer	H	soapers	M
		craneway transfer	H	spinners	M
		de-barking drum	H	tenter frames	M
		edger feed	M	washers	M
		gang feed	M	winders	M
		green chain	M	Windlass	†
		live rolls	H		
		log deck	H		
				Machine tools	
				bending roll	M
				punch press-gear driven	H
				notching press- belt driven	†
				plate planers	H
				tapping machine	H
				other machine tools	
				main drives	M
				auxiliary drives	U
				Metal mills	
				draw bench carriage and main drive	M
				pinch, dryer and scrubber rolls-reversing	†
				slitters	M
				table conveyors	
				non-reversing	
				group drives	M
				individual drives	H
				reversing	
				wire drawing and flattening machine	M
				wire winding machine	M
				Mill-rotary type ball	
				cement kilns	H
				dryers and coolers	H
				kilns, other than cement	H
				pebble rod	H
				plain	H
				wedge bar	H
				tumbling barrels	H
				Mixers	
				concrete mixers	
				-continuous	M
				concrete mixers	
				-intermittent	M
				constant density	U
				variable density	M
				Oil industry	
				chillers	M
				oil well pumping	†
				paraffin filter press	M
				rotary kilns	M
				Paper mills	
				agitators, (mixers)	M
				barker-auxiliaries-hydraulic	M
				barker-mechanical	H
				barking drum	H
				beater and pulper	M
				bleacher	U
				calenders	M
				calenders-super	H
				converting machine, except cutters, platers	M
				conveyors	U
				couch	M
				cutters-plates	H
				cylinders	M
				dryers	M
				felt stretcher	M
				felt whipper	H
				jordans	M

SERIES M

SELECTION PROCEDURE FOR MOTORISED UNITS

EXAMPLE APPLICATION DETAILS

Absorbed power of driven machine = 0.7 kW
 Output speed of gearbox or Input speed of machine = 63 rev/min
 Application = Uniformly loaded belt conveyor
 Duration of service (hours per day) = 24hrs
 Mounting position = 1
 Ambient temperature = 20°C
 Running time (%) = 100%

1 DETERMINE MECHANICAL SERVICE FACTOR (Fm)

Refer to Load Classification by Application, table 3, page 4
 Application = Uniformly loaded belt conveyor

Conveyors-uniformly loaded or fed apron assembly belt bucket chain	U U U U U	U = Uniform load
--	-----------------------	------------------

Refer to mechanical service factor (Fm), table 1, page 3
 Duration of service (hours per day) = 24hrs

Prime mover	Duration of service-hrs per day	Load classification-drive	
		Uniform	Moderate
Electric motor, steam turbine or hydraulic motor	Under 3	0.80	1.00
	3 to 10	1.00	1.25
	Over 10	1.25	1.50

Therefore mechanical service factor (Fm) = 1.25

If the unit is subject to frequent start/stops Fm must be multiplied by factor Fs (see table 2 page 3)

2 DETERMINE REQUIRED OUTPUT TORQUE AT GEARBOX OUTPUTSHAFT

$$\text{Absorbed output torque} = \frac{\text{Absorbed power} \times 9550}{\text{Gearbox output speed}}$$

$$\frac{0.7 \times 9550}{63} = 106 \text{ Nm}$$

3 SELECT GEARED MOTOR

Refer to selection table one motor size larger than absorbed power.
 Absorbed power = 0.7 kW, therefore refer to 0.75 kW selection table, page 34
 Always select from 4 POLE selection table in the first instance as this offers a more economical solution.
 Required output speed of gearbox = 63 rev/min

0.75 kW	N2 R/MIN	i	M2 Nm	Fm	N	UNIT DESIGNATION Column Entry 1 Through 20 Spaces to be filled when entering order	Kg Weight of Base Mount Unit	Motor Frame Size
	Output Speed	Ratio	Output Torque	Service Factor	Overhung Load			
4 POLE	177	8	39	3.47	4000	M 0 2 2 2 8 . 0 _ M _ _ _ . 7 5 A _ _	22.5	80A
	156	9.09	44	3.14	4000	9 . 0		
	127	11.15	54	2.65	4000	1 1 .		
	114	12.37	60	2.45	4000	1 2 .		
	101	14.05	68	2.22	4000	1 4 .		
	89	15.97	78	2.04	3968	1 6 .		
	80	17.58	85	1.86	3878	1 8 .		
	70	20.23	99	1.61	3757	2 0 .		
	64	21.99	107	1.48	4000	2 2 .		
	54	26.4	128	1.24	3847	2 8 .		

4 CHECK OUTPUT TORQUE

Output torque (M2) of selected unit must be equal or more than required output torque at gearbox outputshaft.
 Required output torque at gearbox outputshaft = 106 Nm

0.75 kW	N2 R/MIN	i	M2 Nm	Fm	N	UNIT DESIGNATION Column Entry 1 Through 20 Spaces to be filled when entering order	Kg Weight of Base Mount Unit	Motor Frame Size
	Output Speed	Ratio	Output Torque	Service Factor	Overhung Load			
4 POLE	177	8	39	3.47	4000	M 0 2 2 2 8 . 0 _ M _ _ _ . 7 5 A _ _	22.5	80A
	156	9.09	44	3.14	4000	9 . 0		
	127	11.15	54	2.65	4000	1 1 .		
	114	12.37	60	2.45	4000	1 2 .		
	101	14.05	68	2.22	4000	1 4 .		
	89	15.97	78	2.04	3968	1 6 .		
	80	17.58	85	1.86	3878	1 8 .		
	70	20.23	99	1.61	3757	2 0 .		
	64	21.99	107	1.48	4000	2 2 .		
	54	26.4	128	1.24	3847	2 8 .		

Selected unit's output torque (M2) = 107 Nm, therefore unit is acceptable

Go to point 5

SERIES M

SELECTION PROCEDURE FOR MOTORISED UNITS

5 CHECK SERVICE FACTOR

Service factor (Fm) of selected unit must be equal or more than required service factor.

Required service factor of gearbox = 1.25

0.75 kW	N2 R/MIN	i	M2 Nm	Fm	N	UNIT DESIGNATION	Kg	
	Output Speed	Ratio	Output Torque	Service Factor	Overhung Load	Column Entry 1 Through 20 Spaces to be filled when entering order	Weight of Base Mount Unit	Motor Frame Size
4 POLE	177	8	39	3.47	4000	M 0 2 2 2 8 . 0 _ M _ _ _ . 7 5 A - -	22.5	80A
	156	9.09	44	3.14	4000	9 . 0		
	127	11.15	54	2.65	4000	1 1 .		
	114	12.37	60	2.45	4000	1 2 .		
	101	14.05	68	2.22	4000	1 4 .		
	89	15.97	78	2.04	3968	1 6 .		
	80	17.58	85	1.86	3878	1 8 .		
	70	20.23	99	1.61	3757	2 0 .		
	64	21.99	107	1.48	4000	2 2 .		
	54	26.4	128	1.24	3847	2 8 .		

Selected unit's service factor (Fm) = 1.48, therefore unit is acceptable.

Alternatively a M03 unit could be selected which has a greater service factor

0.75 kW	N2 R/MIN	i	M2 Nm	Fm	N	UNIT DESIGNATION	Kg	
	Output Speed	Ratio	Output Torque	Service Factor	Overhung Load	Column Entry 1 Through 20 Spaces to be filled when entering order	Weight of Base Mount Unit	Motor Frame Size
4 POLE	156	9.09	44	3.76	4000	M 0 3 2 2 9 . 0 _ M _ _ _ . 7 5 A - -	22.5	80A
	127	11.15	54	3.28	4000	1 1 .		
	114	12.37	60	3.07	4000	1 2 .		
	101	14.05	69	2.81	4000	1 4 .		
	89	15.97	77	2.63	3935	1 6 .		
	80	17.58	85	2.42	3844	1 8 .		
	70	20.23	99	2.11	3689	2 0 .		
	64	21.99	107	1.94	3568	2 2 .		
	54	26.4	128	1.63	3045	2 8 .		
	45	31.68	154	1.35	3182	3 2 .		

Selected unit's service factor (Fm) = 1.94, therefore unit is acceptable.

6 CHECK OVERHUNG LOADS

If sprocket, gear, etc is mounted on the outputshaft then refer to Overhung Loads Procedure, page 94, and compare with allowable overhung load (N) of selected unit

Allowable overhung load (N) must be equal or more than calculated overhung load (P)

0.75 kW	N2 R/MIN	i	M2 Nm	Fm	N	UNIT DESIGNATION	Kg	
	Output Speed	Ratio	Output Torque	Service Factor	Overhung Load	Column Entry 1 Through 20 Spaces to be filled when entering order	Weight of Base Mount Unit	Motor Frame Size
4 POLE	177	8	39	3.47	4000	M 0 2 2 2 8 . 0 _ M _ _ _ . 7 5 A - -	22.5	80A
	156	9.09	44	3.14	4000	9 . 0		
	127	11.15	54	2.65	4000	1 1 .		
	114	12.37	60	2.45	4000	1 2 .		
	101	14.05	68	2.22	4000	1 4 .		
	89	15.97	78	2.04	3968	1 6 .		
	80	17.58	85	1.86	3878	1 8 .		
	70	20.23	99	1.61	3757	2 0 .		
	64	21.99	107	1.48	4000	2 2 .		
	54	26.4	128	1.24	3847	2 8 .		

NOTE: If any of the following conditions occur then consult Application Engineering:-

- a) Mass acceleration factor > 10
- b) Ambient temperature is above 40°C

SERIES M

UNIT VERSIONS

UNIT VERSIONS. COLUMN 9 ENTRY

B

- Base Mounted

E

- Flange mount with B14 (C) Flange Mounting (For sizes M01 to M08 only)

Flange Mounted

Letter Entry Depends on Flange Diameter See tables below

Flange
Diameter

Column
9 Entry

120

H

140

J

160

K

200

L

250

N

Flange
Diameter

300

P

350

R

450

F

550

G

Unit Size				Flange Dia	Column 9 Entry
Double	Triple	Quadruple	Quintuple		
M0122	M0132	-	-	120	H
				140	J
				160	K
				200	L
M0222	M0232	-	-	120	H
				140	J
				160	K
				200	L
M0322	M0332	M0342	M0352	120	H
				140	J
				160	K
				200	L
M0422	M0432	M0442	M0452	140	J
				160	K
				200	L
				250	N
M0522	M0532	M0542	M0552	140	J
				160	K
				200	L
				250	N
M0622	M0632	M0642	M0652	200	L
				250	N
				300	P
M0722	M0732	M0742	M0752	200	L
				250	N
				300	P
M0822	M0832	M0842	M0852	300	P
				350	R
M0921	M0931	M0941	M0951	450	F
M1021	M1031	M1041	M1051	450	F
M1321	M1331	M1341	M1351	550	G
M1421	M1431	M1441	M1451	550	G

OUTPUT SHAFT OPTIONS

OUTPUTSHAFT OPTIONS

* Inch shaft has an open ended keyway, therefore no 'L11' dimension is required.

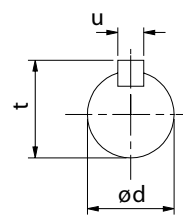
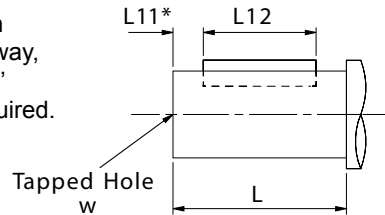

Column 11 Entry

- C Standard
- N Inch

OUTPUTSHAFT OPTIONS - double, triple, quadruple and quintuple reduction

SIZE OF UNIT	TYPE OF OUTPUT SHAFT	COLUMN 11 ENTRY	DIMENSIONS IN MM (Inch Shaft in Inches)						
			ød	L	L11	L12	t	u	w
01	Standard	C	20.015 / 20.002	40	4	32	22.5	6	M6 x 1, 16 deep
	Inch *	N	0.7500"/0.7495"	1.575"	-	1 ⁹ / ₃₂ "	0.829"	³ / ₁₆ "	¹ / ₄ " UNF x 0.63" deep
02	Standard	C	25.015 / 25.002	50	4	40	28	8	M10 x 1.5, 22 deep
	Inch *	N	1.0000"/0.9995"	1.969"	-	1 ⁹ / ₁₆ "	1.106"	¹ / ₄ "	¹ / ₄ " UNF x 0.71" deep
03	Standard	C	25.015 / 25.002	50	4	40	28	8	M10 x 1.5, 22 deep
	Inch *	N	1.0000"/0.9995"	1.969"	-	1 ⁹ / ₁₆ "	1.106"	¹ / ₄ "	¹ / ₄ " UNF x 0.71" deep
04	Standard	C	30.015 / 30.002	60	4	50	33	8	M10 x 1.5, 22 deep
	Inch *	N	1.2500"/1.2495"	2.362"	-	2"	1.359"	¹ / ₄ "	³ / ₈ " UNF x 0.86" deep
05	Standard	C	35.018 / 35.002	70	7	60	38	10	M12 x 1.75, 28 deep
	Inch *	N	1.3750"/1.3745"	2.756"	-	2 ³ / ₈ "	1.507"	⁵ / ₁₆ "	³ / ₈ " UNF x 0.75" deep
06	Standard	C	35.018 / 35.002	70	7	60	38	10	M12 x 1.75, 28 deep
	Inch *	N	1.3750"/1.3745"	2.756"	-	2 ³ / ₈ "	1.507"	⁵ / ₁₆ "	³ / ₈ " UNF x 0.75" deep
07	Standard	C	40.018 / 40.002	80	5	70	43	12	M16 x 2.0, 36 deep
	Inch *	N	1.6250"/1.6240"	3.150"	-	2 ³ / ₈ "	1.784"	³ / ₈ "	⁵ / ₈ " UNF x 1.25" deep
08	Standard	C	50.018 / 50.002	100	10	80	53.5	14	M16 x 2.0, 36 deep
	Inch *	N	2.1250"/2.1240"	3.937"	-	2 ³ / ₄ "	2.338"	¹ / ₂ "	³ / ₄ " UNF x 1.50" deep
09	Standard	C	60.030 / 60.011	120	10	100	64	18	M20 x 2.5, 42 deep
	Inch *	N	2.3750"/2.3740"	4.72"	-	3 ¹¹ / ₁₆ "	2.65"	0.625"	³ / ₄ " UNF 1.65" deep
10	Standard	C	70.030 / 70.011	140	15	110	74.5	20	M20 x 2.5, 42 deep
	Inch *	N	2.875"/2.874"	5.51"	-	4 ⁵ / ₈ "	3.20"	0.75"	³ / ₄ " UNF 1.65" deep
13	Standard	C	90.035 / 90.013	170	15	140	95	25	M24 x 3.0, 50 deep
	Inch *	N	3.625"/3.624"	6.69"	-	5 ¹⁵ / ₁₆ "	4.01"	0.875"	1" UNF 1.97" deep
14	Standard	C	100.035 / 100.013	210	15	180	106	28	M24 x 3.0, 50 deep
	Inch *	N	4.000"/3.999"	8.27"	-	7 ¹ / ₂ "	4.44"	1.00"	1" UNF 1.97" deep

SERIES M

MOTOR ADAPTERS

DOUBLE REDUCTION UNITS

IEC Flanges B14 - Column 12 Entry For Unit Types Column 10 Entries G, H and M Only

MOTOR FRAME FLANGE	UNIT SIZE, NUMBER OF REDUCTIONS, REVISION NUMBER													
	RATIO COVERAGE		M0122	M0222	M0322	M0422	M0522	M0622	M0722					
	3.6 - 9.0	11. - 56.	3.6 - 14.	16. - 56.	3.6 - 14.	16. - 56.	3.6 - 11.	12. - 56.	3.6 - 11.	12. - 56.	5.0 - 12.	14. - 63.	3.6 - 9.0	11. - 56.
71	H	H	-	H	-	H	-	-	-	-	-	-	-	-
80	B	K	B	K	B	K	-	G	-	G	-	G	-	G
90	D	R	D	R	D	R	-	J	-	J	-	J	-	J
100	F	S	F	S	F	S	B	L	B	L	B	L	B	L
112	F	S	F	S	F	S	B	L	B	L	B	L	B	L
132	-	-	-	-	-	-	-	-	-	-	-	-	D	N

■ Limited Availability / Non Preferred

IEC Flanges B5 - Column 12 Entry For Unit Types Column 10 Entries G, H and M Only

MOTOR FRAME FLANGE	UNIT SIZE, NUMBER OF REDUCTIONS, REVISION NUMBER																											
	RATIO COVERAGE		M0122	M0222	M0322	M0422	M0522	M0622	M0722	M0822	M0921	M1021	M1321	M1421														
	3.6 - 9.0	11. - 56.	3.6 - 14.	16. - 56.	3.6 - 14.	16. - 56.	3.6 - 11.	12. - 56.	3.6 - 11.	12. - 56.	5.0 - 12.	14. - 63.	3.6 - 9.0	11. - 56.	3.6 - 14.	16. - 56.	1.4 - 14.	16. - 71.	1.4 - 14.	16. - 71.	2.8 - 14.	16. - 45.	50. - 71.	2.8 - 14.	16. - 45.	50. - 71.		
63	F	F	-	F	-	F	-	V	-	V	-	V	-	-	-	-	-	-	-	-	-	-	-	-	-	-	-	-
71	G	G	-	G	-	G	-	D	-	D	-	D	-	-	-	-	-	-	-	-	-	-	-	-	-	-	-	-
80	A	J	A	J	A	J	W	F	W	F	W	F	-	F	-	D	-	E	-	-	-	-	-	-	-	-	-	-
90	C	Q	C	Q	C	Q	Y	H	Y	H	Y	H	-	H	-	E	-	F	-	-	-	-	-	-	-	-	-	-
100	-	-	-	-	-	-	A	K	A	K	A	K	A	K	A	F	-	G	-	E	-	G	N	-	S	W	-	-
112	-	-	-	-	-	-	A	K	A	K	A	K	A	K	A	F	-	G	-	E	-	G	N	-	S	W	-	-
132	-	-	-	-	-	-	N	P	N	P	N	P	N	P	C	M	B	G	-	H	-	F	-	H	P	-	T	X
160	-	-	-	-	-	-	-	-	-	-	-	-	-	E	-	C	H	A	J	A	G	A	J	Q	A	G	N	-
180	-	-	-	-	-	-	-	-	-	-	-	-	-	-	-	-	B	K	B	H	B	K	R	B	H	P	-	-
200	-	-	-	-	-	-	-	-	-	-	-	-	-	-	-	-	C	-	C	-	C	L	S	C	J	Q	-	-
225	-	-	-	-	-	-	-	-	-	-	-	-	-	-	-	-	-	D	-	D	-	D	M	T	D	K	R	-
250	-	-	-	-	-	-	-	-	-	-	-	-	-	-	-	-	-	-	-	-	-	E	U	-	E	L	-	-
280	-	-	-	-	-	-	-	-	-	-	-	-	-	-	-	-	-	-	-	-	-	F	W	-	F	M	-	-

NEMA Flanges C Face - Column 12 Entry For Unit Types Column 10 Entries A, E and N Only

MOTOR FRAME FLANGE	UNIT SIZE, NUMBER OF REDUCTIONS, REVISION NUMBER																											
	RATIO COVERAGE		M0122	M0222	M0322	M0422	M0522	M0622	M0722	M0822	M0921	M1021	M1321	M1421														
	3.6 - 9.0	11. - 56.	3.6 - 14.	16. - 56.	3.6 - 14.	16. - 56.	3.6 - 11.	12. - 56.	3.6 - 11.	12. - 56.	5.0 - 12.	14. - 63.	3.6 - 9.0	11. - 56.	3.6 - 14.	16. - 56.	1.4 - 14.	16. - 71.	1.4 - 14.	16. - 71.	2.8 - 14.	16. - 45.	50. - 71.	2.8 - 14.	16. - 45.	50. - 71.		
56c	T	U	T	U	T	U	-	Q	-	Q	-	Q	-	Q	-	M	-	-	-	-	-	-	-	-	-	-	-	-
143/145TC	V	W	V	W	V	W	-	R	-	R	-	R	-	R	-	N	-	-	-	-	-	-	-	-	-	-	-	-
182/184TC	X	-	X	-	X	-	S	T	S	T	S	T	S	T	J	P	-	S	-	P	-	N	A	-	W	X	-	-
213/215TC	-	-	-	-	-	-	U	-	U	-	U	-	U	-	U	V	K	Q	-	T	-	Q	-	P	B	-	N	A
254/256TC	-	-	-	-	-	-	-	-	-	-	-	-	-	-	W	-	L	U	P	U	L	R	F	Q	C	E	P	B
284/286TC	-	-	-	-	-	-	-	-	-	-	-	-	-	-	-	-	-	Q	V	M	S	G	R	D	F	Q	C	-
324/326TC	-	-	-	-	-	-	-	-	-	-	-	-	-	-	-	-	-	-	R	W	N	T	H	S	E	G	R	D
364/365TC	-	-	-	-	-	-	-	-	-	-	-	-	-	-	-	-	-	-	-	-	-	-	J	T	-	H	S	-
404/405TC	-	-	-	-	-	-	-	-	-	-	-	-	-	-	-	-	-	-	-	-	-	-	K	U	-	J	T	-

SERIES M

MOTOR ADAPTERS

TRIPLE REDUCTION UNITS

IEC Flanges B14 - Column 12 Entry For Unit Types Column 10 Entries G, H and M Only

MOTOR FRAME FLANGE	UNIT SIZE, NUMBER OF REDUCTIONS, REVISION NUMBER								
	RATIO COVERAGE	M0132	M0232	M0332	M0432	M0532	M0632	M0732	M0832
		56. - 200	56. - 200	56. - 200	56. - 200	56. - 200	63. - 25	56. - 200	56. - 200
71	COLUMN 12 ENTRY	H	H	H	H	H	-	-	
80		K	K	K	K	K	K	G	G
90		R	R	R	R	R	R	J	J
100		S	S	S	S	S	S	L	L
112		S	S	S	S	S	S	L	L
132		-	-	-	-	-	-	-	-

■ Limited Availability / Non Preferred

IEC Flanges B5 - Column 12 Entry For Unit Types Column 10 Entries G, H and M Only

MOTOR FRAME FLANGE	UNIT SIZE, NUMBER OF REDUCTIONS, REVISION NUMBER																	
	RATIO COVERAGE	M0132	M0232	M0332	M0432	M0532	M0632	M0732	M0832	M0931	M1031	M1331	M1431					
		56. - 200	56. - 200	56. - 200	56. - 200	56. - 200	63. - 25	56. - 200	56. - 200	56. - 200	56. - 200	40. - 50.	56. - 160	180 - 250	40. - 50.	56. - 160	180 - 250	
63	COLUMN 12 ENTRY	F	F	F	F	F	F	V	-	-	-	-	-	-	-	-	-	
71		G	G	G	G	G	G	D	-	-	-	-	-	-	-	-	-	-
80		J	J	J	J	J	J	F	F	L	E	-	-	-	-	-	-	-
90		Q	Q	Q	Q	Q	Q	H	H	M	F	-	-	-	-	-	-	-
100		-	-	-	-	-	-	-	K	K	N	G	-	G	N	-	G	N
112		-	-	-	-	-	-	-	K	K	N	G	-	G	N	-	G	N
132		-	-	-	-	-	-	-	P	M	-	H	-	H	P	-	H	P
160		-	-	-	-	-	-	-	-	-	-	J	A	J	Q	A	J	Q
180		-	-	-	-	-	-	-	-	-	-	K	B	K	R	B	K	R
200		-	-	-	-	-	-	-	-	-	-	-	C	L	S	C	L	S
225		-	-	-	-	-	-	-	-	-	-	-	D	M	T	D	M	T
250		-	-	-	-	-	-	-	-	-	-	-	E	U	-	E	W	-
280		-	-	-	-	-	-	-	-	-	-	-	F	W	-	F	X	-

NEMA Flanges C Face - Column 12 Entry For Unit Types Column 10 Entries A, E and N Only

MOTOR FRAME FLANGE	UNIT SIZE, NUMBER OF REDUCTIONS, REVISION NUMBER																	
	RATIO COVERAGE	M0132	M0232	M0332	M0432	M0532	M0632	M0732	M0832	M0931	M1031	M1331	M1431					
		56. - 200	56. - 200	56. - 200	56. - 200	56. - 200	63. - 25	56. - 200	56. - 200	56. - 200	56. - 200	40. - 50.	56. - 160	180 - 250	40. - 50.	56. - 160	180 - 250	
56c	COLUMN 12 ENTRY	U	U	U	U	U	U	Q	Q	X	-	-	-	-	-	-	-	
143/145TC		W	W	W	W	W	W	R	R	Y	-	-	-	-	-	-	-	
182/184TC		-	-	-	-	-	-	-	T	T	Z	S	-	N	A	-	N	A
213/215TC		-	-	-	-	-	-	-	-	V	-	T	-	P	B	-	P	B
254/256TC		-	-	-	-	-	-	-	-	-	-	U	F	Q	C	F	Q	C
284/286TC		-	-	-	-	-	-	-	-	-	-	V	G	R	D	G	R	D
324/326TC		-	-	-	-	-	-	-	-	-	-	W	H	S	E	H	S	E
364/365TC		-	-	-	-	-	-	-	-	-	-	-	J	T	-	J	T	-
404/405TC		-	-	-	-	-	-	-	-	-	-	-	K	U	-	K	U	-

SERIES M

MOTOR ADAPTERS

QUADRUPLE REDUCTION UNITS

IEC Flanges B14 - Column 12 Entry For Unit Types Column 10 Entries G, H and M Only

MOTOR FRAME FLANGE	UNIT SIZE, NUMBER OF REDUCTIONS, REVISION NUMBER										
	RATIO COVERAGE	M0342	M0442	M0542	M0642	M0742	M0842	M0941	M1041	M1341	M1441
71	COLUMN 12 ENTRY	H	H	H	H	H	-	-	-	-	-
80		K	K	K	K	K	G	G	G	G	G
90		R	R	R	R	R	J	J	J	J	J
100		-	-	-	-	-	L	L	L	L	L
112		-	-	-	-	-	L	L	L	L	L
132		-	-	-	-	-	-	-	N	N	N

IEC Flanges B5 - Column 12 Entry For Unit Types Column 10 Entries G, H and M Only

MOTOR FRAME FLANGE	UNIT SIZE, NUMBER OF REDUCTIONS, REVISION NUMBER										
	RATIO COVERAGE	M0342	M0442	M0542	M0642	M0742	M0842	M0941	M1041	M1341	M1441
63	COLUMN 12 ENTRY	F	F	F	F	F	V	V	-	-	-
71		G	G	G	G	G	D	D	-	-	-
80		J	J	J	J	J	F	F	F	F	F
90		Q	Q	Q	Q	Q	H	H	H	H	H
100		-	-	-	-	-	K	K	K	K	K
112		-	-	-	-	-	K	K	K	K	K
132	-	-	-	-	-	P	P	M	M	M	

■ Limited Availability / Non Preferred

NEMA Flanges C Face - Column 12 Entry For Unit Types Column 10 Entries A, E and N Only

MOTOR FRAME FLANGE	UNIT SIZE, NUMBER OF REDUCTIONS, REVISION NUMBER										
	RATIO COVERAGE	M0342	M0442	M0542	M0642	M0742	M0842	M0941	M1041	M1341	M1441
56c	COLUMN 12 ENTRY	U	U	U	U	U	Q	Q	Q	Q	Q
143/145TC		W	W	W	W	W	R	R	R	R	R
182/184TC		-	-	-	-	-	T	T	T	T	T
213/215TC		-	-	-	-	-	-	-	V	V	V

SERIES M

MOTOR ADAPTERS

QUINTUPLE REDUCTION UNITS

IEC Flanges B14 - Column 12 Entry For Unit Types Column 10 Entries G, H and M Only

MOTOR FRAME FLANGE	UNIT SIZE, NUMBER OF REDUCTIONS, REVISION NUMBER										
	RATIO COVERAGE	M0352	M0452	M0552	M0652	M0752	M0852	M0951	M1051	M1351	M1451
71	COLUMN 12 ENTRY	H	H	H	H	H	H	H	-	-	-
80		K	K	K	K	K	K	K	G	G	G
90		R	R	R	R	R	R	R	R	J	J

IEC Flanges B5 - Column 12 Entry For Unit Types Column 10 Entries G, H and M Only

MOTOR FRAME FLANGE	UNIT SIZE, NUMBER OF REDUCTIONS, REVISION NUMBER										
	RATIO COVERAGE	M0352	M0452	M0552	M0652	M0752	M0852	M0951	M1051	M1351	M1451
63	COLUMN 12 ENTRY	F	F	F	F	F	F	F	-	-	-
71		G	G	G	G	G	G	G	-	-	-
80		J	J	J	J	J	J	J	F	F	F
90		Q	Q	Q	Q	Q	Q	Q	H	H	H
100		-	-	-	-	-	-	-	K	K	K
112		-	-	-	-	-	-	-	K	K	K

 Limited Availability / Non Preferred

NEMA Flanges C Face - Column 12 Entry For Unit Types Column 10 Entries A, E and N Only

MOTOR FRAME FLANGE	UNIT SIZE, NUMBER OF REDUCTIONS, REVISION NUMBER										
	RATIO COVERAGE	M0352	M0452	M0552	M0652	M0752	M0852	M0951	M1051	M1351	M1451
56c	COLUMN 12 ENTRY	U	U	U	U	U	U	U	Q	Q	Q
143/145TC		W	W	W	W	W	W	W	R	R	R
182/184TC		-	-	-	-	-	-	-	-	T	T

SERIES M

LUBRICATION

M01,M02,M03,M04,M05,M06,& M07 Units, are supplied factory filled with EP mineral oil (Grade 6E) appropriate to the intended mounting position. If the unit is supplied without lubricant the unit must be filled with the correct lubricant and quantity as listed below.

M08,M09,M10,M13,& M14 Units, require filling with EP mineral oil (Grade 6E)
Lubricant quantities are approximate fill until oil escapes from the level plug hole, fit ventilator plug (when supplied) in the appropriate position for the required mounting position. If the unit is supplied without lubricant the unit must be filled with the correct lubricant and quantity.

TEMPERATURE LIMITATIONS

The standard lubricant is suitable for operation in ambient temperatures of 0° to 35°C, outside of this consult Table 1 or Application Engineers.

TABLE 1 OIL GRADES

LUBRICANT	AMBIENT TEMPERATURE RANGE		
	5°C to 20°C (type E) -30°C to 20°C (type H)	0°C to 35°C	20°C to 50°C
EP Mineral Oil (type E)	5E (VG 220)	6E (VG 320)	7E (VG 460)
Polyalphaolefin based Synthetic (type H)	5H (VG 220)	5H (VG 220)	6H (VG 320)

TABLE 2 Lubrication Quantity (Litres)

DOUBLE REDUCTION & FINAL STAGE QUADRUPLE OR QUINTUPLE REDUCTION													
Unit Size		M0122	M0222	M0322	M0422	M0522	M0622	M0722	M0822	M0921	M1021	M1321	M1421
MOUNTING POSITION	1	0.5	0.8	0.8	1.5	1.5	2.0	2.6	4.2	10.5	14.0	17.0	24.0
	2	0.8	1.2	1.2	1.8	1.8	2.0	2.9	6.3	12.0	22.0	31.0	49.0
	3	0.6	0.7	0.7	1.6	1.6	1.9	2.7	5.4	12.0	22.0	31.0	49.0
	4	0.8	1.2	1.2	1.8	1.8	1.7	3.0	7.3	12.0	19.0	28.0	41.0
	5	0.7	1.1	1.1	2.0	2.0	2.2	3.2	6.8	16.8	32.0	47.0	72.0
	6	1.0	1.4	1.4	2.6	2.6	2.8	4.7	9.3	16.4	26.0	38.0	65.0

Unit Size		M0132	M0232	M0332	M0432	M0532	M0632	M0732	M0832	M0931	M1031	M1331	M1431
MOUNTING POSITION	1	0.6	0.8	0.8	1.6	1.6	2.1	2.7	4.4	11.5	15.0	18.0	24.5
	2	0.9	1.3	1.3	1.9	1.9	2.1	3.0	6.5	12.0	24.0	33.0	50.0
	3	0.7	0.7	0.7	1.7	1.7	2.0	2.8	5.6	12.0	24.0	33.0	50.0
	4	0.9	1.2	1.2	1.9	1.9	1.8	3.1	7.5	12.0	21.0	30.0	43.0
	5	0.7	1.1	1.1	2.1	2.1	2.3	3.3	6.8	16.8	32.0	47.0	72.0
	6	1.1	1.6	1.6	2.7	2.7	2.9	4.8	9.7	16.5	28.0	40.0	67.0

PRIMARY STAGE QUADRUPLE REDUCTION (Quantities obtained from above double and triple sizes indicated)										
Unit Size	M0342	M0442	M0542	M0642	M0742	M0842	M0941	M1041	M1341	M1441
PRIMARY UNIT	M0122	M0322	M0322	M0322	M0322	M0522	M0522	M0722	M0722	M0722
SECONDARY UNIT	M0322	M0422	M0522	M0622	M0722	M0822	M0921	M1021	M1321	M1421

PRIMARY STAGE QUINTUPLE REDUCTION (Quantities obtained from above double and triple sizes indicated)										
Unit Size	M0352	M0452	M0552	M0652	M0752	M0852	M0951	M1051	M1351	M1451
PRIMARY UNIT	M0132	M0332	M0332	M0332	M0332	M0532	M0532	M0732	M0732	M0732
SECONDARY UNIT	M0322	M0422	M0522	M0622	M0722	M0822	M0921	M1021	M1321	M1421

MOUNTING POSITIONS

COLUMN 13 ENTRY

Enter for units with no oil fill

Base Mounted Units

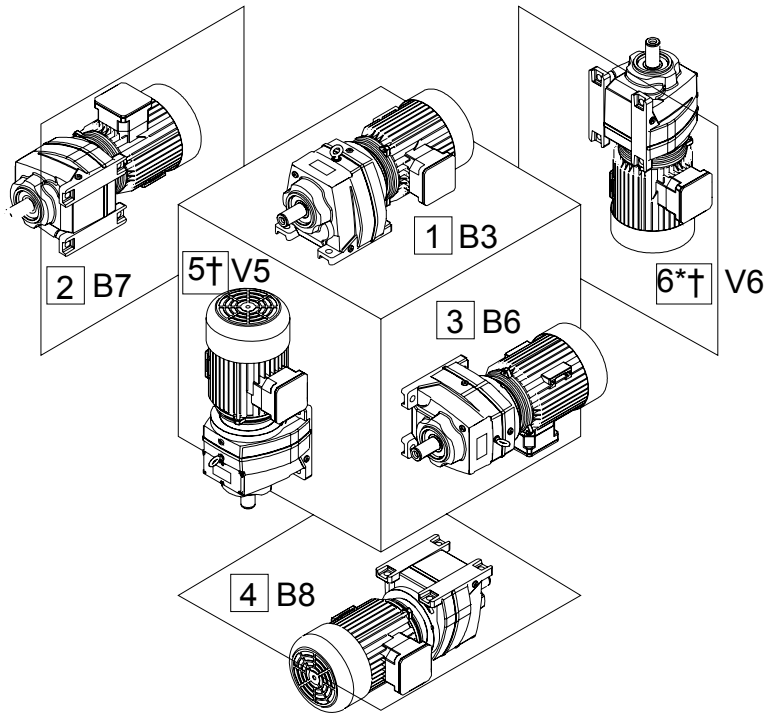

Flange Mounted Units

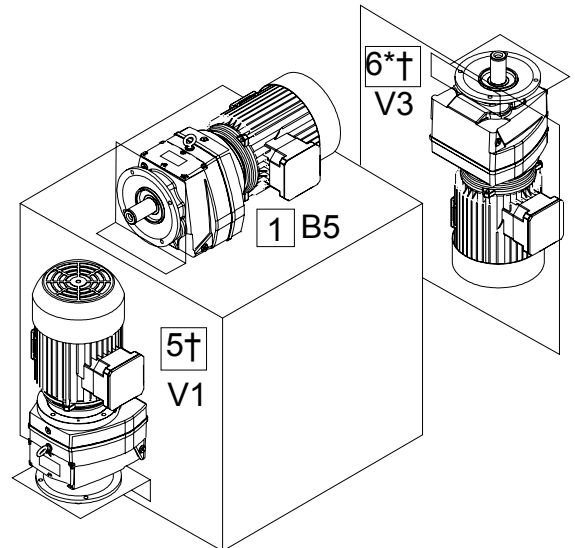

* Mounting Position 6 is not recommended for Geared Motors - Consult Application Engineering
 † Gear Units selected for use in mounting positions 5 and 6 should only be used with overall ratios greater or equal to those shown in the table below

Unit Size	Input Speed (rpm)			
	< 1000	< 1500	< 1800	> 1800
M01 - M08	All	All	All	Consult Application Engineering
M09	2.0	4.0	4.5	
M10	4.0	8.0	9.0	
M13	6.3	11.0	14.0	
M14	12.0	18.0	22.0	

MOUNTING POSITIONS - SHOWN AS MOTORISED - APPLIES ALSO FOR REDUCERS

COLUMN 14 ENTRY

ALL MOTORS

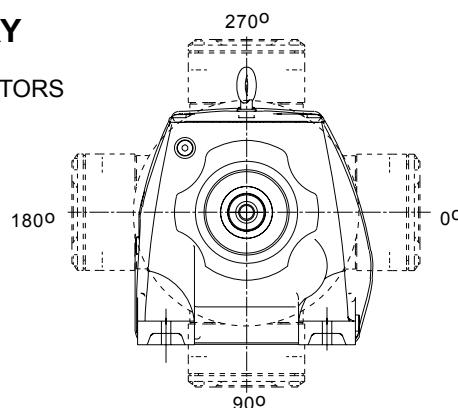

Column 14 Entry	Terminal Box Position
A	0°
B	90°
C	180°
D	270°
-	Reducer or no motor fitted

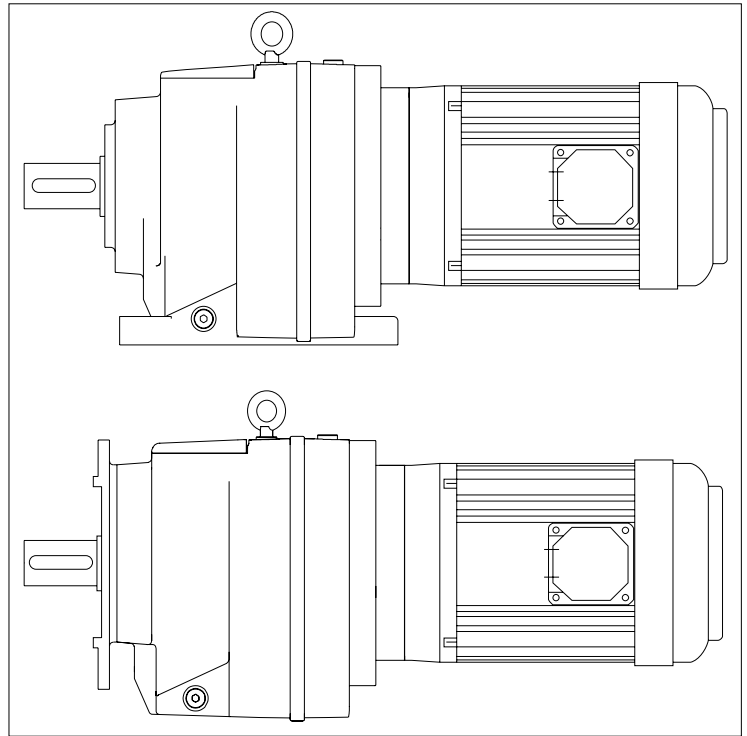

MOTORISED
SERIES M

SERIES M

EXPLANATION & USE OF RATINGS & SERVICE FACTORS

TEFC squirrel cage three phase motors
4 poles = 1500 rpm 400V, 50Hz, S1 IP55, Class F

Output Power Kw	Frame Size	Speed (RPM)	I (A)	Ist	Tst	J
				I	T	(Kgm2)
0.12	63	1360	0.6	2.6	2.5	0.000
0.18	63	1370	0.72	3	2.2	0.000
0.25	71	1400	0.83	3.5	2.2	0.001
0.37	71	1410	1.12	4	2.2	0.001
0.55	80A	1420	1.45	4	2.2	0.002
0.75	80A	1420	2.9	4.5	2.2	0.002
1.1	90S	1410	2.59	5	2.2	0.003
1.5	90L	1420	3.45	5	2.4	0.004
2.2	100L	1430	4.8	5.5	2.4	0.007
3	100L	1430	6.48	5.5	2.5	0.008
4	100L	1420	8.73	5.5	2.5	0.009
4	112M	1435	8.6	7	2.9	0.015
5.5	112M	1425	11.4	7.1	2.8	0.018
5.5	132S	1450	11.1	7.3	2.2	0.031
7.5	132M	1450	14.8	7.9	2.5	0.038
9	132M	1450	18	8.1	2.8	0.043
11	132M	1450	21	8.3	3	0.048
11	160M	1460	21.5	6.7	2.9	0.067
15	160L	1455	28.5	6.8	2	0.091
18.5	160L	1450	36	6.9	2.9	0.102
18.5	180M	1470	35	6.7	3.1	0.161
22	180L	1470	41	6.8	2.9	0.191
30	180L	1465	56	6.9	3.2	0.225
30	200L	1475	56	6.7	2.6	0.29
37	200L	1475	68	7.8	3.6	0.34
37	225S	1480	68	6.6	2.4	0.37
45	225M	1480	83	6.7	2.7	0.42
55	225M	1480	100	7.3	3.1	0.49
55	250M	1480	98	7.5	2.3	0.72
75	250M	1480	132	7	2.4	0.88
75	280S	1483	137	6.8	2.4	1.15
90	280M	1484	163	7.1	2.7	1.4
110	280M	1483	195	7.5	2.7	1.7

High Power Motor (Non Standard)

I = Nominal current
Ist/I = Starting current factor
Tst/T = Starting torque factor
J = Motor moment of inertia

Recalculation Factors

Recalculation factors for current at rated voltages other than 400V, 50 Hz.

Rated voltage at 50Hz and motor wound for	Recalculation factor
220V	1.82
230V	1.74
415V	0,96
500V	0,80
660V	0,61
690V	0,58

TEFC squirrel cage three phase motors
6 poles = 1000 rpm 400V, 50Hz, S1 IP55, Class F

Output Power Kw	Frame Size	Speed (RPM)	I (A)	Ist	Tst	J
				I	T	(Kgm2)
0.12	63	900	0.6	2.1	2.1	0.000
0.18	71	920	0.75	2.5	2	0.001
0.25	71	920	0.92	3	2	0.001
0.37	80A	920	1.25	3.5	2.1	0.002
0.55	80B	930	1.78	3.5	2.1	0.002
0.75	90S	930	2.36	4	1.9	0.003
1.1	90L	930	3.25	4	1.9	0.004
1.5	100L	940	5.8	4.5	1.9	0.009
2.2	112M	940	5.8	4.5	1.9	0.009
2.2	100L	940	5.4	5.6	2.1	0.015
3	112M	935	7.2	5.5	2.4	0.018
3	132S	960	6.9	6.1	2.4	0.031
4	132M	960	8.7	7.1	2.6	0.038
5.5	132M	955	11.9	6.9	2.8	0.045
7.5	160M	970	15.4	6.7	2	0.089
11	160L	970	23	7.1	2.2	0.107
15	180L	970	31	7	2.1	0.217
18.5	180L	965	37.5	6.2	2	0.237
18.5	200L	985	36	7	2.5	0.370
22	200L	980	43	7.2	2.5	0.430
30	200L	980	56	7.5	3.3	0.490
30	225M	985	56	6.6	2.5	0.640
37	225S	985	69	7.7	3.1	0.750
37	250M	985	69	7.3	2.8	1.160
45	250S	985	82	7.3	2.8	1.490
45	280S	990	85	6.6	2.6	1.650

High Power Motor (Non Standard)

I = Nominal current
Ist/I = Starting current factor
Tst/T = Starting torque factor
J = Motor moment of inertia

60 Hz Operation

Motors wound for a certain voltage at 50 Hz can be operated at 60 Hz, without any modifications, subject to the following changes in their data

Motor wound for 50 Hz and	Connected to 60 Hz and	Data at 60 Hz in percentage of values at 50 Hz					
		P kW	n rpm	I A	Ist/I	T Nm	Tst/T
400V	380V	100	120	100	80	83	66
	400V	100	120	98	83	83	70
	415V	105	120	100	88	86	78
	440V	110	120	100	95	91	85
	460V	115	120	100	100	96	95
	480V	120	120	100	105	100	100

SERIES M

MOTOR DETAILS

B14 'C' FACE

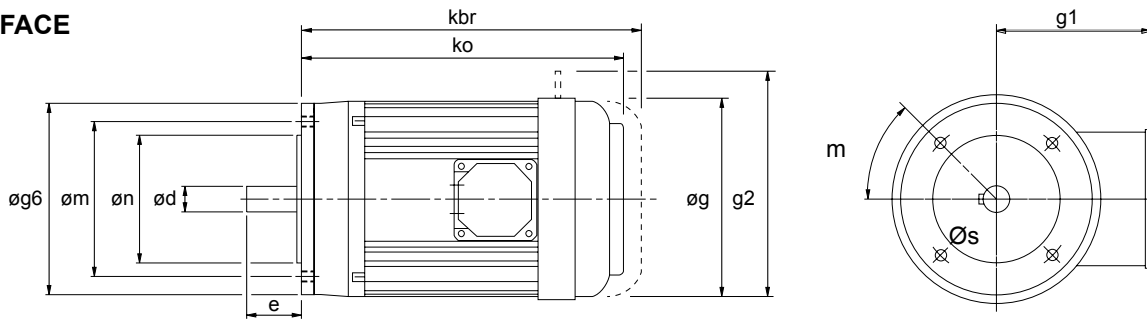

MOTOR FRAME SIZE	Øg6	Øm	Øn	Ød	e	ko*	kbr*	Øg	g1*	m	Øs
71	105	85	70	14	30	221	265	138	102	45°	4 x M6
80A	120	100	80	19	40	239	291	157	125	45°	4 x M6
80B	120	100	80	19	40	248	300	157	125	45°	4 x M6
90S	140	115	95	24	50	260	312	177	133	45°	4 x M8
90L	140	115	95	24	50	275	327	177	133	45°	4 x M8
100L	160	130	110	28	60	310	370	197	144	45°	4 x M8
112M	160	130	110	28	60	325	399	219	155	45°	4 x M8
132S	200	165	130	38	80	392	475	235	172	45°	4 x M10
132M	200	165	130	38	80	412	495	235	172	45°	4 x M10

B5 'D' FACE

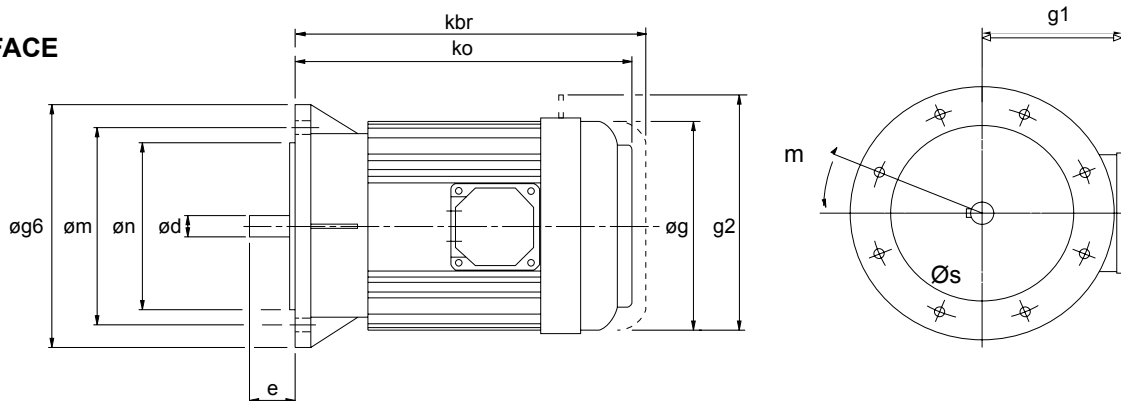

MOTOR FRAME SIZE	Øg6	Øm	Øn	Ød	e	ko*	kbr*	Øg	g1*	m	Øs
63	140	115	95	11	23	218	263	122	96	45°	4 x M8
71	160	130	110	14	30	221	265	138	102	45°	4 x M8
80A	200	165	130	19	40	239	291	157	125	45°	4 x M10
80B	200	165	130	19	40	248	300	157	125	45°	4 x M10
90S	200	165	130	24	50	260	312	177	133	45°	4 x M10
90L	200	165	130	24	50	275	327	177	133	45°	4 x M10
100L	250	215	180	28	60	310	370	197	144	45°	4 x M12
112M	250	215	180	28	60	325	399	219	155	45°	4 x M12
132S	300	265	230	38	80	392	475	235	172	45°	4 x M12
132M	300	265	230	38	80	412	495	235	172	45°	4 x M12
160M	350	300	250	42	110	455	538	273	282	45°	4 x M16
160L	350	300	250	42	110	500	583	273	282	45°	4 x M16
180M	350	300	250	48	110	557	-	382	307	22.5°	4 x M16
180L	350	300	250	48	110	595	-	382	307	22.5°	4 x M16
200L	400	350	300	55	110	658	-	420	372	-	4 x M16
225S	450	400	350	60	140	671	-	458	427	-	8 x M16
225M	450	400	350	60	140	696	-	458	427	-	8 x M16
250M	550	500	450	65	140	771	-	510	490	-	8 x M16
280S	550	500	450	75	140	837	-	576	520	-	8 x M16
280M	550	500	450	75	140	888	-	576	520	-	8 x M16

* Motor lengths for own brand standard motors. These lengths may vary if alternative motor is fitted.

SERIES M

ADDITIONAL MOTOR FEATURES

ADDITIONAL MOTOR FEATURES - COLUMN 19 ENTRY

Column 19 Entry	Brake Motor	Hand Release on Brake	Forced Ventilation/ Constant Blower (TECB)	Thermistors	Special
-					
A	•				
B	•	•			
C			•		
D	•		•		
E	•	•	•		
F				•	
G	•			•	
H	•	•		•	
K			•	•	
L	•		•	•	
M	•	•	•	•	
S					•

Please refer to Application Engineering for details of the following additional motor features

- PGF encoder flange
- Wash down
- Customised brake torque
- Separate brake supply
- Aluminium fan
- Anti Condensation heater
- Bi-metal temperature detectors, Thermostat
- EExEIIT3
- Ex nA II T3
- IP56
- IP65
- Metal fan cover
- Rain cowl
- Separate terminal box

SERIES M

ADDITIONAL GEARBOX FEATURES

ADDITIONAL GEARBOX FEATURES - COLUMN 20 ENTRY

Column 20 Entry	Double Outputshaft Oil Seals *	Oil Level Glass ** M07 - M14	Motorised Backstop ***		Special
			CW Rotation	CCW Rotation	
-					
A	•				
B		•			
C	•	•			
D			•		
E	•		•		
F		•	•		
G	•	•	•		
H				•	
I	•			•	
J		•		•	
K	•	•		•	
L					•

Please refer to Application Engineering for details of the following additional gearbox features

- Prime paint only
- Wash down
- BISSC compatible
- Special oil (food compatible, bio-degradable, different viscosities etc)

* Double Oil Seals for output shafts sizes M08 to M14 only

** Oil level glass is NOT AVAILABLE for M01 to M06 units

*** IEC frame sizes 100 - 200 NEMA frame sizes 182TC - 326TC

SERIES M

SELECTION TABLES

GEARED MOTORS

0.12 kW

4 POLE

N2 R/MIN	i	M2 Nm	Fm	N	Unit Designation	Kg	Motor Size
Output Speed	Ratio	Output Torque	Service Factor	Overhung Load	Column Entry 1 Through 20 Spaces to be filled when entering order	Weight	
363	3.75	3	19.46	1690	M 0 1 2 2 3 . 6 _ M _ _ _ _ . 1 2 A - -	13.5	63
268	5.07	4	16.34	1790	5 . 0		
236	5.76	4	15.24	1840	5 . 6		
208	6.53	5	14.07	1880	6 . 3		
163	8.35	6	11.65	1900	8 . 0		
151	9	7	10.94	1900	9 . 0		
120	11.36	9	9.07	1900	1 1 .		
106	12.88	10	8.29	1900	1 2 .		
92	14.71	11	7.48	1900	1 4 .		
83	16.37	13	6.75	1900	1 6 .		
75	18.05	14	6.11	1900	1 8 .		
68	19.86	16	5.56	1900	2 0 .		
58	23.27	18	4.74	1900	2 2 .		
49	27.92	22	3.96	1900	2 8 .		
42	32.54	26	3.41	1900	3 2 .		
38	36.16	29	3.07	1900	3 6 .		
31	43.54	35	2.38	1900	4 5 .		
27	49.91	40	1.78	1900	5 0 .		
24	56.72	45	1.54	1900	5 6 .		
23	58.46	46	1.93	1900	M 0 1 3 2 5 6 . _ M _ _ _ _ . 1 2 A - -	14.5	63
21	64.45	51	1.75	1900	6 3 .		
19	70.93	56	1.59	1900	7 1 .		
16	83.1	66	1.36	1900	8 0 .		
14	99.7	79	1.13	1830	1 0 0		
12	116.22	92	0.97	1650	1 1 2		
11	129.13	102	0.88	1360	1 2 5		
25	53.54	43	3.69	4000	M 0 2 2 2 5 6 . _ M _ _ _ _ . 1 2 A - -	16.5	63
24	57.03	45	3.5	4000	M 0 2 3 2 5 6 . _ M _ _ _ _ . 1 2 A - -	17.5	63
22	62.87	50	3.17	4000	6 3 .		
20	69.19	55	2.88	4000	7 1 .		
17	81.07	64	2.46	4000	8 0 .		
14	97.26	77	2.06	4000	1 0 0		
12	113.37	90	1.77	4000	1 1 2		
11	125.97	100	1.59	4000	1 2 5		
9	151.69	121	1.32	4000	1 6 0		
7.8	173.87	139	1.15	4000	1 8 0		
6.9	197.6	157	1.02	4000	2 0 0		
20	69.19	55	3.77	4000	M 0 3 3 2 7 1 . _ M _ _ _ _ . 1 2 A - -	17.5	63
17	81.07	64	3.22	4000	8 0 .		
14	97.26	77	2.69	4000	1 0 0		
12	113.37	90	2.31	4000	1 1 2		
11	125.97	100	2.08	4000	1 2 5		
9	151.69	121	1.72	4000	1 6 0		
7.8	173.87	138	1.51	4000	1 8 0		
6.9	197.6	157	1.33	4000	2 0 0		
5.8	234.96	182	1.15	3026	M 0 3 4 2 2 2 5 _ M _ _ _ _ . 1 2 A - -	26.5	63
5.2	261.37	202	1.03	3026	2 5 0		
4.7	287.83	222	0.94	3026	2 8 0		
4.3	317.33	245	0.85	3026	3 0 0		
12	115.82	92	3.64	7200	M 0 4 3 2 1 1 2 _ M _ _ _ _ . 1 2 A - -	26.5	63
10	130.5	104	3.24	7200	1 2 5		
9	151.71	121	2.78	7200	1 6 0		
7.9	172.19	137	2.45	7200	1 8 0		
6.9	195.75	156	2.16	7200	2 0 0		
9	151.71	121	3.7	7200	M 0 5 3 2 1 6 0 _ M _ _ _ _ . 1 2 A - -	27.5	63
7.9	172.19	138	3.26	7200	1 8 0		
6.9	195.75	156	2.87	7200	2 0 0		
6.4	213.18	171	3.66	7200	M 0 6 3 2 2 0 0 _ M _ _ _ _ . 1 2 A - -	32.5	63

0.12 kW

6 POLE

NOTE

Other output speeds are available using 2 and 8 pole motors - Consult Application Engineering

232	3.75	4	14.27	1810	M 0 1 2 2 3 . 6 _ M _ _ _ _ . 1 2 C - -	13.5	63
172	5.07	6	11.71	1900	5 . 0		
151	5.76	7	10.65	1900	5 . 6		
133	6.53	8	9.59	1900	6 . 3		
104	8.35	10	8.01	1900	8 . 0		
97	9	11	7.54	1900	9 . 0		
77	11.36	14	6.19	1900	1 1 .		
68	12.88	16	5.47	1900	1 2 .		
59	14.71	18	4.79	1900	1 4 .		
53	16.37	20	4.31	1900	1 6 .		
48	18.05	22	3.9	1900	1 8 .		
44	19.86	25	3.55	1900	2 0 .		
37	23.27	29	3.04	1900	2 2 .		
31	27.92	35	2.54	1900	2 8 .		
27	32.54	41	2.17	1900	3 2 .		
24	36.16	45	1.96	1900	3 6 .		
20	43.54	55	1.52	1900	4 5 .		
17	49.91	63	1.14	1900	5 0 .		
15	56.72	71	0.99	1900	5 6 .		

SERIES M

SELECTION TABLES

GEARED MOTORS

0.12 kW

6 POLE

N2 R/MIN	i	M2 Nm	Fm	N	Unit Designation	Kg	Motor Size
Output Speed	Ratio	Output Torque	Service Factor	Overhung Load	Column Entry [1] Through [20] Spaces to be filled when entering order	Weight	
15	58.46	72	1.23	1900	M 0 1 3 2 5 6 . . M 1 2 C - -	14.5	63
13	64.45	80	1.12	1900	6 3 .		
12	70.93	88	1.01	1900	7 1 .		
10	83.1	103	0.87	1360	8 0 .		
21	41.49	52	3.04	4000	M 0 2 2 2 4 5 . . M 1 2 C - -	16.5	63
18	47.09	59	2.68	4000	5 0 .		
16	53.54	67	2.36	4000	5 6 .		
15	57.03	71	2.24	4000	M 0 2 3 2 5 6 . . M 1 2 C - -	17.5	63
14	62.87	79	2.02	4000	6 3 .		
13	69.19	86	1.84	4000	7 1 .		
11	81.07	101	1.57	4000	8 0 .		
8.9	97.26	121	1.31	4000	1 0 0		
7.7	113.37	142	1.13	4000	1 1 2		
6.9	125.97	156	1.02	4000	1 2 5		
5.7	151.69	189	0.85	3200	1 6 0		
13	69.19	86	2.41	4000	M 0 3 3 2 7 1 . . M 1 2 C - -	17.5	63
11	81.07	101	2.05	4000	8 0 .		
8.9	97.26	121	1.71	4000	1 0 0		
7.7	113.37	141	1.47	4000	1 1 2		
6.9	125.97	157	1.33	4000	1 2 5		
5.7	151.69	189	1.1	3500	1 6 0		
5	173.87	217	0.96	3000	1 8 0		
4.4	197.6	247	0.85	2400	2 0 0		
7.5	115.82	145	2.33	7200	M 0 4 3 2 1 1 2 . . M 1 2 C - -	26.5	63
6.7	130.5	163	2.07	7200	1 2 5		
5.7	151.71	190	1.77	7200	1 6 0		
5.1	172.19	215	1.57	7200	1 8 0		
4.4	195.75	244	1.38	7200	2 0 0		
5.7	151.71	190	2.36	7200	M 0 5 3 2 1 6 0 . . M 1 2 C - -	27.5	63
5.1	172.19	215	2.08	7200	1 8 0		
4.4	195.75	245	1.84	7200	2 0 0		
4.1	213.18	267	2.34	7200	M 0 6 3 2 2 0 0 . . M 1 2 C - -	32.5	63

0.18 kW

4 POLE

385	3.75	4	13.07	1681	M 0 1 2 2 3 . 6 . . M 1 8 A - -	13.5	63
270	5.07	6	10.97	1778	5 . 0		
238	5.76	6	10.24	1826	5 . 6		
210	6.53	7	9.45	1856	6 . 3		
164	8.35	10	7.82	1873	8 . 0		
152	9	10	7.35	1872	9 . 0		
121	11.36	13	6.09	1874	1 1 .		
106	12.88	15	5.56	1874	1 2 .		
93	14.71	17	5.02	1854	1 4 .		
84	16.37	19	4.53	1890	1 6 .		
76	18.05	21	4.1	1877	1 8 .		
69	19.86	24	3.73	1852	2 0 .		
59	23.27	28	3.19	1881	2 2 .		
49	27.92	33	2.66	1819	2 8 .		
42	32.54	39	2.29	1878	3 2 .		
38	36.16	43	2.06	1854	3 6 .		
31	43.54	52	1.6	1890	4 5 .		
27	49.91	60	1.2	1849	5 0 .		
24	56.72	68	1.03	1900	5 6 .		
23	58.46	69	1.3	1724	M 0 1 3 2 5 6 . . M 1 8 A - -	14.5	63
21	64.45	76	1.18	1590	6 3 .		
19	70.93	84	1.07	1780	7 1 .		
16	83.1	98	0.91	1450	8 0 .		
38	35.69	43	3.72	4000	M 0 2 2 2 3 6 . . M 1 8 A - -	16.5	63
33	41.49	50	3.19	4000	4 5 .		
29	47.09	56	2.81	4000	5 0 .		
26	53.54	64	2.48	3956	5 6 .		
24	57.03	68	2.35	4000	M 0 2 3 2 5 6 . . M 1 8 A - -	17.5	63
22	62.87	75	2.13	4000	6 3 .		
20	69.19	82	1.94	4000	7 1 .		
17	81.07	96	1.65	3913	8 0 .		
14	97.26	115	1.38	4000	1 0 0		
12	113.37	134	1.19	3976	1 1 2		
11	125.97	149	1.07	4000	1 2 5		
9	151.69	180	0.89	4000	1 6 0		
33	41.49	50	3.96	4000	M 0 3 2 2 4 5 . . M 1 8 A - -	16.5	63
29	47.09	56	3.57	4000	5 0 .		
26	53.54	64	3.19	4000	5 6 .		
24	57.03	68	3.07	4000	M 0 3 3 2 5 6 . . M 1 8 A - -	17.5	63
22	62.87	75	2.78	4000	6 3 .		
20	69.19	82	2.53	3743	7 1 .		
17	81.07	96	2.16	3913	8 0 .		
14	97.26	115	1.81	3654	1 0 0		
12	113.37	134	1.55	3976	1 1 2		
11	125.97	149	1.4	3718	1 2 5		
9	151.69	180	1.15	3173	1 6 0		
7.9	173.87	206	1.01	3420	1 8 0		
6.9	197.6	234	0.89	2660	2 0 0		

NOTE
Other output speeds are available using 2 and 8 pole motors - Consult Application Engineering

SERIES M

SELECTION TABLES

GEARED MOTORS

0.18 kW

4 POLE

N2 R/MIN	i	M2 Nm	Fm	N	Unit Designation	Kg	Motor Size
Output Speed	Ratio	Output Torque	Service Factor	Overhung Load	Column Entry 1 Through 20 Spaces to be filled when entering order	Weight	
19	73.95	88	3.82	7200	M 0 4 3 2 7 1 . . . M _ _ _ _ . 1 8 A - -	26.5	63
17	80.4	96	3.51	7200	8 0 .		
14	96.52	115	2.93	7200	1 0 0		
12	115.82	138	2.45	7102	1 1 2		
10	130.5	155	2.17	7200	1 2 5		
9	151.71	180	1.87	7178	1 6 0		
8	172.19	205	1.65	7034	1 8 0		
7	195.75	233	1.45	7200	2 0 0		
5.9	232.81	269	1.25	7125	M 0 4 4 2 2 5 . . . M _ _ _ _ . 1 8 A - -	38.5	63
5.3	260.47	300	1.12	7125	2 5 0		
4.9	277.62	320	1.06	7125	2 8 0		
4.5	305.72	353	0.96	7125	3 0 0		
3.8	362.32	416	0.81	7125	3 6 0		
14	96.52	115	3.89	7200	M 0 5 3 2 1 0 0 . . . M _ _ _ _ . 1 8 A - -	27.5	63
12	115.82	138	3.25	7200	1 1 2		
10	130.5	155	2.89	7200	1 2 5		
9	151.71	181	2.48	6660	1 6 0		
8	172.19	205	2.19	6902	1 8 0		
7	195.75	233	1.93	6628	2 0 0		
5.9	232.81	271	1.66	4809	M 0 5 4 2 2 5 . . . M _ _ _ _ . 1 8 A - -	40.5	63
5.3	260.47	302	1.49	4809	2 5 0		
4.9	277.62	322	1.4	4809	2 8 0		
4.5	305.72	355	1.27	4809	3 0 0		
3.8	362.32	419	1.07	4809	3 6 0		
3.3	416.75	482	0.93	4809	4 0 0		
3.1	444.96	514	0.87	4809	4 5 0		
2.8	483.76	559	0.8	4809	5 0 0		
8.5	161.57	192	3.24	7200	M 0 6 3 2 1 6 0 . . . M _ _ _ _ . 1 8 A - -	32.5	63
7.3	187.83	224	2.79	7200	1 8 0		
6.4	213.18	254	2.46	7200	2 0 0		
6.4	215.23	252	2.48	7200	M 0 6 4 2 2 2 5 . . . M _ _ _ _ . 1 8 A - -	45.5	63
5.8	237.02	278	2.25	7200	2 5 0		
5	272.91	318	1.66	7200	2 8 0		
4.4	313.91	366	1.44	7200	3 0 0		
3.8	365.1	426	1.4	7200	3 6 0		
3.5	396.93	463	1.29	7200	4 0 0		
3.1	444.1	516	1.21	7200	4 5 0		
2.6	533.13	620	1.01	7200	5 0 0		
2.4	568.23	661	0.95	7200	6 5 0		
6	229	268	3.24	4677	M 0 7 4 2 2 2 5 . . . M _ _ _ _ . 1 8 A - -	52.5	63
5.3	259.68	303	2.86	4676	2 5 0		
4.8	286.42	334	2.59	4676	2 8 0		
4.3	315.41	368	2.35	4676	3 0 0		
3.8	361.21	421	2.06	4675	3 6 0		
3.3	415.49	484	1.79	4675	4 0 0		
2.9	469.77	546	1.59	4675	4 5 0		
2.7	510.72	594	1.46	4675	5 0 0		
2.3	592.12	687	1.26	4675	6 5 0		
1.9	710.84	824	1.05	4675	7 3 0		
1.6	847.84	979	0.89	4674	8 6 0		

0.18 kW

6 POLE

240	3.75	6	9.84	1791	M 0 1 2 2 3 . 6 . . . M _ _ _ _ . 1 8 C - -	14.5	71
178	5.07	9	8.07	1874	5 . 0		
156	5.76	10	7.34	1874	5 . 6		
138	6.53	12	6.61	1874	6 . 3		
108	8.35	15	5.52	1874	8 . 0		
100	9	16	5.2	1868	9 . 0		
79	11.36	21	4.27	1822	1 1 .		
70	12.88	23	3.77	1792	1 2 .		
61	14.71	27	3.3	1783	1 4 .		
55	16.37	30	2.97	1786	1 6 .		
50	18.05	33	2.69	1750	1 8 .		
45	19.86	36	2.45	1719	2 0 .		
39	23.27	42	2.09	1712	2 2 .		
32	27.92	51	1.75	1634	2 8 .		
28	32.54	59	1.5	1631	3 2 .		
25	36.16	66	1.35	1540	3 6 .		
21	43.54	80	1.05	1496	4 5 .		
15	58.46	105	0.85	730	M 0 1 3 2 5 6 . . . M _ _ _ _ . 1 8 C - -	15.5	71
34	26.4	48	3.29	4000	M 0 2 2 2 2 8 . . . M _ _ _ _ . 1 8 C - -	18.5	71
28	31.68	58	2.74	4000	3 2 .		
25	35.69	65	2.44	4000	3 6 .		
22	41.49	76	2.09	3824	4 5 .		
19	47.09	86	1.85	3706	5 0 .		
17	53.54	98	1.63	3571	5 6 .		
16	57.03	103	1.54	3829	M 0 2 3 2 5 6 . . . M _ _ _ _ . 1 8 C - -	19.5	71
14	62.87	114	1.4	3685	6 3 .		
13	69.19	125	1.27	3532	7 1 .		
11	81.07	147	1.08	3243	8 0 .		
9.3	97.26	176	0.91	3270	1 0 0		
28	31.68	58	3.58	4000	M 0 3 2 2 3 2 . . . M _ _ _ _ . 1 8 C - -	18.5	71
25	35.69	65	3.19	4000	3 6 .		
22	41.49	76	2.69	4000	4 5 .		
19	47.09	86	2.41	4000	5 0 .		
17	53.54	98	2.09	4000	5 6 .		
16	57.03	103	2.02	4000	M 0 3 3 2 5 6 . . . M _ _ _ _ . 1 8 C - -	19.5	71
14	62.87	114	1.82	4000	6 3 .		
13	69.19	125	1.66	3441	7 1 .		
11	81.07	147	1.42	3243	8 0 .		
9.3	97.26	176	1.18	3039	1 0 0		
7.9	113.37	205	1.02	2493	1 1 2		
7.1	125.97	228	0.92	1766	1 2 5		

NOTE

Other output speeds are available using 2 and 8 pole motors - Consult Application Engineering

SERIES M

SELECTION TABLES

GEARED MOTORS

0.18 kW

6 POLE

N2 R/MIN	i	M2 Nm	Fm	N	Unit Designation	Kg	Motor Size
Output Speed	Ratio	Output Torque	Service Factor	Overhung Load	Column Entry [1] Through [20] Spaces to be filled when entering order	Weight	
15	58.38	106	3.17	7200	M 0 4 3 2 5 6 . . . M 1 8 C - -	28.5	71
14	64.29	117	2.88	7200	6 3		
12	73.95	134	2.51	7200	7 1		
11	80.4	146	2.31	7200	8 0		
9.3	96.52	175	1.92	7200	1 0 0		
7.8	115.82	210	1.6	6442	1 1 2		
6.9	130.5	236	1.43	6712	1 2 5		
5.9	151.71	276	1.22	6295	1 6 0		
5.2	172.19	312	1.08	5901	1 8 0		
4.6	195.75	354	0.95	6203	2 0 0		
3.9	232.81	412	0.82	7125	M 0 4 4 2 2 2 5 . . M 1 8 C - -	40.5	71
12	73.95	135	3.33	7200	M 0 5 3 2 7 1 . . M 1 8 C - -	28.5	71
11	80.4	146	3.06	7200	8 0		
9.3	96.52	175	2.56	7200	1 0 0		
7.8	115.82	210	2.14	7200	1 1 2		
6.9	130.5	237	1.9	7200	1 2 5		
5.9	151.71	276	1.63	6195	1 6 0		
5.2	172.19	313	1.44	5820	1 8 0		
4.6	195.75	355	1.27	5274	2 0 0		
3.9	232.81	413	1.09	4809	M 0 5 4 2 2 2 5 . . M 1 8 C - -	41.5	71
3.5	260.47	461	0.97	4809	2 5 0		
3.2	277.62	492	0.91	4809	2 8 0		
2.9	305.72	542	0.83	4809	3 0 0		
7.5	119.5	218	2.87	7200	M 0 6 3 2 1 1 2 . . M 1 8 C - -	33.5	71
6.3	143.39	261	2.4	7200	1 2 5		
5.6	161.57	293	2.13	7200	1 6 0		
4.8	187.83	342	1.83	7200	1 8 0		
4.2	213.18	387	1.61	6215	2 0 0		
4.2	215.23	384	1.62	7200	M 0 6 4 2 2 2 5 . . M 1 8 C - -	47.5	71
3.8	237.02	423	1.47	7200	2 5 0		
3.3	272.91	486	1.09	7200	2 8 0		
2.9	313.91	558	0.95	7200	3 0 0		
2.5	365.1	649	0.92	7200	3 6 0		
2.3	396.93	706	0.85	7200	4 0 0		
3.9	229	408	2.12	4677	M 0 7 4 2 2 2 5 . . M 1 8 C - -	54.5	71
3.5	259.68	462	1.88	4676	2 5 0		
3.1	286.42	510	1.7	4676	2 8 0		
2.9	315.41	562	1.54	4676	3 0 0		
2.5	361.21	642	1.35	4675	3 6 0		
2.2	415.49	738	1.17	4675	4 0 0		
1.9	469.77	833	1.04	4675	4 5 0		
1.8	510.72	906	0.96	4675	5 0 0		
1.5	592.12	1048	0.83	4675	6 5 0		

0.25 kW

4 POLE

373	3.75	6	9.62	1670	M 0 1 2 2 3 . 6 . . M 2 5 A - -	14.5	71
276	5.07	8	8.07	1764	5 0		
243	5.76	9	7.53	1810	5 6		
214	6.53	10	6.95	1829	6 3		
168	8.35	13	5.75	1841	8 0		
156	9	14	5.41	1840	9 0		
123	11.36	18	4.48	1845	1 1		
109	12.88	21	4.09	1845	1 2		
95	14.71	24	3.7	1800	1 4		
86	16.37	26	3.33	1879	1 6		
78	18.05	29	3.02	1850	1 8		
70	19.86	32	2.75	1796	2 0		
60	23.27	38	2.34	1860	2 2		
50	27.92	45	1.96	1724	2 8		
43	32.54	53	1.68	1853	3 2		
39	36.16	59	1.52	1801	3 6		
32	43.54	71	1.17	1880	4 5		
28	49.91	81	0.88	1790	5 0		
24	58.46	94	0.95	1520	M 0 1 3 2 5 6 . . M 2 5 A - -	15.5	71
22	64.45	103	0.87	1230	6 3		
53	26.4	43	3.68	4000	M 0 2 2 2 2 8 . . M 2 5 A - -	18.5	71
44	31.68	52	3.07	4000	3 2		
39	35.69	58	2.73	4000	3 6		
34	41.49	68	2.35	4000	4 5		
30	47.09	77	2.07	4000	5 0		
26	53.54	87	1.82	3906	5 6		
25	57.03	92	1.73	4000	M 0 2 3 2 5 6 . . M 2 5 A - -	19.5	71
22	62.87	102	1.57	4000	6 3		
20	69.19	112	1.43	4000	7 1		
17	81.07	131	1.22	3812	8 0		
14	97.26	157	1.02	4000	1 0 0		
12	113.37	183	0.87	3950	1 1 2		
39	35.69	58	3.57	3837	M 0 3 2 2 3 6 . . M 2 5 A - -	18.5	71
34	41.49	68	2.91	3921	4 5		
30	47.09	77	2.63	3828	5 0		
26	53.54	87	2.34	3941	5 6		
25	57.03	92	2.26	3884	M 0 3 3 2 5 6 . . M 2 5 A - -	19.5	71
22	62.87	102	2.05	3772	6 3		
20	69.19	112	1.86	3443	7 1		
17	81.07	131	1.59	3812	8 0		
14	97.26	157	1.33	3251	1 0 0		
12	113.37	183	1.14	3950	1 1 2		
11	125.97	203	1.03	3390	1 2 5		
9.2	151.69	245	0.85	2209	1 6 0		

NOTE
Other output speeds are available using 2 and 8 pole motors - Consult Application Engineering

SERIES M

SELECTION TABLES

GEARED MOTORS

0.25 kW

4 POLE

N2 R/MIN	i	M2 Nm	Fm	N	Unit Designation	Kg	Motor Size
Output Speed	Ratio	Output Torque	Service Factor	Overhung Load	Column Entry 1 Through 20 Spaces to be filled when entering order	Weight	
24	58.38	94	3.56	7200	M 0 4 3 2 5 6 . . . M _ _ _ _ . 2 5 A - -	28.5	71
22	64.29	104	3.23	7200	6 3 . . .		
19	73.95	120	2.81	7191	7 1 . . .		
17	80.4	130	2.58	7171	8 0 . . .		
15	96.52	156	2.16	7200	1 0 0 . . .		
12	115.82	187	1.8	6988	1 1 2 . . .		
11	130.5	211	1.6	7200	1 2 5 . . .		
9.2	151.71	245	1.37	7153	1 6 0 . . .		
8.1	172.19	278	1.21	6841	1 8 0 . . .		
7.2	195.75	317	1.07	7200	2 0 0 . . .		
6	232.81	366	0.92	7125	M 0 4 4 2 2 2 5 0 _ M _ _ _ _ . 2 5 A - -	40.5	71
5.4	260.47	408	0.83	7125			
19	73.95	120	3.73	7200	M 0 5 3 2 7 1 . . . M _ _ _ _ . 2 5 A - -	28.5	71
17	80.4	131	3.43	7200	8 0 . . .		
15	96.52	157	2.87	6902	1 0 0 . . .		
12	115.82	188	2.39	6965	1 1 2 . . .		
11	130.5	211	2.12	6764	1 2 5 . . .		
9.2	151.71	246	1.83	6030	1 6 0 . . .		
8.1	172.19	279	1.61	6555	1 8 0 . . .		
7.2	195.75	317	1.42	5962	2 0 0 . . .		
6	232.81	368	1.22	4809	M 0 5 4 2 2 2 5 0 _ M _ _ _ _ . 2 5 A - -	41.5	71
5.4	260.47	411	1.09	4809	2 5 0 . . .		
5	277.62	438	1.03	4809	2 8 0 . . .		
4.6	305.72	483	0.93	4809	3 0 0 . . .		
14	99.54	162	3.86	7200	M 0 6 3 2 1 0 0 0 _ M _ _ _ _ . 2 5 A - -	33.5	71
12	119.5	194	3.22	7200	1 1 2 . . .		
10	143.39	232	2.69	7200	1 2 5 . . .		
8.7	161.57	262	2.39	7200	1 6 0 . . .		
7.5	187.83	305	2.05	7200	1 8 0 . . .		
6.6	213.18	346	1.81	7200	2 0 0 . . .		
6.5	215.23	342	1.82	7200	M 0 6 4 2 2 2 5 0 _ M _ _ _ _ . 2 5 A - -	47.5	71
5.9	237.02	377	1.65	7200	2 5 0 . . .		
5.1	272.91	433	1.22	7200	2 8 0 . . .		
4.5	313.91	498	1.06	7200	3 0 0 . . .		
3.8	365.1	579	1.03	7200	3 6 0 . . .		
3.5	396.93	629	0.95	7200	4 0 0 . . .		
3.2	444.1	702	0.89	7200	4 5 0 . . .		
6.1	229	364	2.38	4677	M 0 7 4 2 2 2 5 0 _ M _ _ _ _ . 2 5 A - -	54.5	71
5.4	259.68	412	2.1	4676	2 5 0 . . .		
4.9	286.42	454	1.91	4676	2 8 0 . . .		
4.4	315.41	501	1.73	4676	3 0 0 . . .		
3.9	361.21	572	1.51	4675	3 6 0 . . .		
3.4	415.49	658	1.32	4675	4 0 0 . . .		
3	469.77	743	1.17	4675	4 5 0 . . .		
2.7	510.72	807	1.07	4675	5 0 0 . . .		
2.4	592.12	934	0.93	4675	6 5 0 . . .		

0.25 kW

6 POLE

240	3.75	9	7.09	1768	M 0 1 2 2 3 . 6 _ M _ _ _ _ . 2 5 C - -	14.5	71
178	5.07	13	5.81	1845	5 . 0 . . .		
156	5.76	14	5.29	1844	5 . 6 . . .		
138	6.53	16	4.76	1845	6 . 3 . . .		
108	8.35	21	3.97	1845	8 . 0 . . .		
100	9	23	3.75	1831	9 . 0 . . .		
79	11.36	29	3.08	1731	1 1 . . .		
70	12.88	33	2.71	1666	1 2 . . .		
61	14.71	37	2.38	1647	1 4 . . .		
55	16.37	41	2.14	1653	1 6 . . .		
50	18.05	46	1.94	1576	1 8 . . .		
45	19.86	50	1.76	1507	2 0 . . .		
39	23.27	59	1.51	1493	2 2 . . .		
32	27.92	71	1.26	1325	2 8 . . .		
28	32.54	83	1.08	1319	3 2 . . .		
25	36.16	92	0.97	1121	3 6 . . .		
44	20.23	51	3.08	4000	M 0 2 2 2 2 0 . . . M _ _ _ _ . 2 5 C - -	18.5	71
41	21.99	56	2.84	4000	2 2 . . .		
34	26.4	67	2.37	3771	2 8 . . .		
28	31.68	80	1.98	3813	3 2 . . .		
25	35.69	91	1.75	3712	3 6 . . .		
22	41.49	106	1.51	3619	4 5 . . .		
19	47.09	120	1.33	3365	5 0 . . .		
17	53.54	136	1.17	3071	5 6 . . .		
16	57.03	144	1.11	3630	M 0 2 3 2 5 6 . . . M _ _ _ _ . 2 5 C - -	19.5	71
14	62.87	159	1	3318	6 3 . . .		
13	69.19	174	0.92	2986	7 1 . . .		
41	21.99	56	3.7	3873	M 0 3 2 2 2 2 . . . M _ _ _ _ . 2 5 C - -	18.5	71
34	26.4	67	3.09	3771	2 8 . . .		
28	31.68	81	2.58	3695	3 2 . . .		
25	35.69	91	2.3	3695	3 6 . . .		
22	41.49	106	1.94	3562	4 5 . . .		
19	47.09	120	1.73	3508	5 0 . . .		
17	53.54	136	1.51	3419	5 6 . . .		
16	57.03	144	1.45	3331	M 0 3 3 2 5 6 . . . M _ _ _ _ . 2 5 C - - 19.5	71	
14	62.87	159	1.31	3243	6 3 . . .		
13	69.19	174	1.2	2790	7 1 . . .		
11	81.07	204	1.02	2359	8 0 . . .		
9.3	97.26	245	0.85	1920	1 0 0 . . .		

NOTE

Other output speeds are available using 2 and 8 pole motors - Consult Application Engineering

SERIES M

SELECTION TABLES

GEARED MOTORS

0.25 kW

6 POLE

N2 R/MIN	i	M2 Nm	Fm	N	Unit Designation	Kg	Motor Size
Output Speed	Ratio	Output Torque	Service Factor	Overhung Load	Column Entry [1] Through [20] Spaces to be filled when entering order	Weight	
15	58.38	148	2.28	6774	M 0 4 3 2 5 6 . _ M _ _ _ _ . 2 5 C - -	28.5	71
14	64.29	162	2.07	6944	6 3 .		
12	73.95	187	1.8	6749	7 1 .		
11	80.4	203	1.66	6620	8 0 .		
9.3	96.52	244	1.38	6609	1 0 0		
7.8	115.82	292	1.15	5558	1 1 2		
6.9	130.5	328	1.03	6144	1 2 5		
5.9	151.71	383	0.88	5239	1 6 0		
15	58.38	148	3.04	7200	M 0 5 3 2 5 6 . _ M _ _ _ _ . 2 5 C - -	28.5	71
14	64.29	163	2.76	7200	6 3 .		
12	73.95	187	2.4	6652	7 1 .		
11	80.4	204	2.2	6594	8 0 .		
9.3	96.52	244	1.84	6315	1 0 0		
7.8	115.82	292	1.54	6146	1 1 2		
6.9	130.5	329	1.37	5841	1 2 5		
5.9	151.71	383	1.17	5023	1 6 0		
5.2	172.19	434	1.03	4280	1 8 0		
4.6	195.75	493	0.91	3331	2 0 0		
12	72.28	183	3.41	7200	M 0 6 3 2 6 3 . _ M _ _ _ _ . 2 5 C - -	33.5	71
11	79.6	202	3.09	7200	7 1 .		
10	91.56	232	2.69	7200	8 0 .		
9	99.54	252	2.48	7200	1 0 0		
7.5	119.5	302	2.07	6988	1 1 2		
6.3	143.39	362	1.73	6562	1 2 5		
5.6	161.57	408	1.53	6914	1 6 0		
4.8	187.83	475	1.32	6375	1 8 0		
4.2	213.18	538	1.16	5067	2 0 0		
4.2	215.23	534	1.17	7200	M 0 6 4 2 2 2 5 _ M _ _ _ _ . 2 5 C - -	47.5	71
3.8	237.02	588	1.06	7200	2 5 0		
3.9	229	567	1.53	4677	M 0 7 4 2 2 2 5 _ M _ _ _ _ . 2 5 C - -	54.5	71
3.5	259.68	642	1.35	4676	2 5 0		
3.1	286.42	708	1.22	4676	2 8 0		
2.9	315.41	780	1.11	4676	3 0 0		
2.5	361.21	892	0.97	4675	3 6 0		
2.2	415.49	1026	0.85	4675	4 0 0		

0.37 kW

4 POLE

373	3.75	9	6.5	1652	M 0 1 2 2 3 . 6 _ M _ _ _ _ . 3 7 A - -	14.5	71
276	5.07	12	5.45	1740	5 . 0		
243	5.76	14	5.09	1782	5 . 6		
214	6.53	15	4.7	1782	6 . 3		
168	8.35	20	3.89	1787	8 . 0		
156	9	22	3.65	1785	9 . 0		
123	11.36	27	3.03	1795	1 1 .		
109	12.88	31	2.77	1795	1 2 .		
95	14.71	35	2.5	1708	1 4 .		
86	16.37	39	2.25	1860	1 6 .		
78	18.05	43	2.04	1804	1 8 .		
70	19.86	48	1.86	1701	2 0 .		
60	23.27	56	1.58	1824	2 2 .		
50	27.92	67	1.32	1562	2 8 .		
43	32.54	78	1.14	1810	3 2 .		
39	36.16	87	1.03	1710	3 6 .		
80	17.58	42	3.73	4000	M 0 2 2 2 1 8 . _ M _ _ _ _ . 3 7 A - -	18.5	71
69	20.23	49	3.24	4000	2 0 .		
64	21.99	53	2.97	4000	2 2 .		
53	26.4	64	2.49	3963	2 8 .		
44	31.68	77	2.08	4000	3 2 .		
39	35.69	86	1.85	4000	3 6 .		
34	41.49	100	1.59	4000	4 5 .		
30	47.09	114	1.4	4000	5 0 .		
26	53.54	129	1.23	3819	5 6 .		
25	57.03	136	1.17	4000	M 0 2 3 2 5 6 . _ M _ _ _ _ . 3 7 A - -	19.5	71
22	62.87	151	1.06	4000	6 3 .		
20	69.19	166	0.96	4000	7 1 .		
17	81.07	194	0.82	3640	8 0 .		
64	21.99	53	3.89	3856	M 0 3 2 2 2 2 . _ M _ _ _ _ . 3 7 A - -	18.5	71
53	26.4	64	3.26	3681	2 8 .		
44	31.68	77	2.71	3727	3 2 .		
39	35.69	86	2.41	3560	3 6 .		
34	41.49	101	1.97	3786	4 5 .		
30	47.09	114	1.77	3533	5 0 .		
26	53.54	130	1.58	3840	5 6 .		
25	57.03	136	1.53	3686	M 0 3 3 2 5 6 . _ M _ _ _ _ . 3 7 A - -	19.5	71
22	62.87	151	1.38	3383	6 3 .		
20	69.19	166	1.26	2930	7 1 .		
17	81.07	194	1.08	3640	8 0 .		
14	97.26	232	0.9	2560	1 0 0		

NOTE
Other output speeds are available using 2 and 8 pole motors - Consult Application Engineering

SERIES M

SELECTION TABLES

GEARED MOTORS

0.37 kW

4 POLE

N2 R/MIN	i	M2 Nm	Fm	N	Unit Designation	Kg	Motor Size
Output Speed	Ratio	Output Torque	Service Factor	Overhung Load	Column Entry 1 Through 20 Spaces to be filled when entering order	Weight	
24	58.38	140	2.41	7087	M 0 4 3 2 5 6 . _ M _ _ _ _ . 3 7 A - -	28.5	71
22	64.29	154	2.18	7200	6 3 .		
19	73.95	178	1.9	7176	7 1 .		
17	80.4	193	1.75	7123	8 0 .		
15	96.52	232	1.46	7200	1 0 0		
12	115.82	277	1.22	6793	1 1 2		
11	130.5	312	1.08	7200	1 2 5		
9.2	151.71	363	0.93	7110	1 6 0		
8.1	172.19	412	0.82	6510	1 8 0		
24	58.38	141	3.18	7200	M 0 5 3 2 5 6 . _ M _ _ _ _ . 3 7 A - -	28.5	71
22	64.29	155	2.9	7200	6 3 .		
19	73.95	178	2.52	6687	7 1 .		
17	80.4	193	2.32	7005	8 0 .		
15	96.52	232	1.94	6393	1 0 0		
12	115.82	278	1.62	6563	1 1 2		
11	130.5	313	1.44	6018	1 2 5		
9.2	151.71	364	1.23	4950	1 6 0		
8.1	172.19	413	1.09	5960	1 8 0		
7.2	195.75	469	0.96	4820	2 0 0		
6	232.81	545	0.82	4809	M 0 5 4 2 2 2 5 _ M _ _ _ _ . 3 7 A - -	41.5	71
19	72.28	173	3.6	7200	M 0 6 3 2 6 3 . _ M _ _ _ _ . 3 7 A - -	33.5	71
18	79.6	192	3.24	7200	7 1 .		
15	91.56	220	2.84	7200	8 0 .		
14	99.54	240	2.61	7200	1 0 0		
12	119.5	287	2.17	7200	1 1 2		
10	143.39	344	1.82	7200	1 2 5		
8.7	161.57	388	1.61	7200	1 6 0		
7.5	187.83	451	1.39	7200	1 8 0		
6.6	213.18	512	1.22	7200	2 0 0		
6.5	215.23	507	1.23	7200	M 0 6 4 2 2 2 5 _ M _ _ _ _ . 3 7 A - -	47.5	71
5.9	237.02	559	1.12	7200	2 5 0		
5.1	272.91	641	0.82	7200	2 8 0		
6.1	229	539	1.61	4677	M 0 7 4 2 2 2 5 _ M _ _ _ _ . 3 7 A - -	54.5	71
5.4	259.68	610	1.42	4676	2 5 0		
4.9	286.42	672	1.29	4676	2 8 0		
4.4	315.41	741	1.17	4676	3 0 0		
3.9	361.21	847	1.02	4675	3 6 0		
3.4	415.49	974	0.89	4675	4 0 0		

0.37 kW

6 POLE

245	3.75	13	4.9	1730	M 0 1 2 2 3 . 6 _ M _ _ _ _ . 3 7 C - -	18.5	80A
182	5.07	18	4.01	1795	5 . 0		
160	5.76	21	3.65	1792	5 . 6		
141	6.53	24	3.29	1795	6 . 3		
110	8.35	30	2.75	1795	8 . 0		
102	9	33	2.59	1767	9 . 0		
81	11.36	42	2.12	1575	1 1 .		
71	12.88	47	1.88	1451	1 2 .		
63	14.71	54	1.64	1415	1 4 .		
56	16.37	60	1.48	1425	1 6 .		
51	18.05	66	1.34	1278	1 8 .		
46	19.86	73	1.22	1146	2 0 .		
40	23.27	86	1.04	1117	2 2 .		
33	27.92	103	0.87	795	2 8 .		
74	12.37	46	3.47	4000	M 0 2 2 2 1 2 . _ M _ _ _ _ . 3 7 C - -	22.5	80A
65	14.05	52	3.06	4000	1 4 .		
58	15.97	59	2.69	4000	1 6 .		
52	17.58	65	2.45	4000	1 8 .		
45	20.23	75	2.13	3841	2 0 .		
42	21.99	81	1.96	3765	2 2 .		
35	26.4	97	1.63	3380	2 8 .		
29	31.68	117	1.36	3493	3 2 .		
26	35.69	131	1.21	3220	3 6 .		
22	41.49	153	1.04	3267	4 5 .		
20	47.09	174	0.92	2779	5 0 .		
17	53.54	197	0.81	2215	5 6 .		
58	15.97	59	3.52	4000	M 0 3 2 2 1 6 . _ M _ _ _ _ . 3 7 C - -	22.5	80A
52	17.58	65	3.19	3933	1 8 .		
45	20.23	75	2.77	3768	2 0 .		
42	21.99	81	2.56	3657	2 2 .		
35	26.4	97	2.13	3380	2 8 .		
29	31.68	117	1.78	3173	3 2 .		
26	35.69	131	1.59	3173	3 6 .		
22	41.49	153	1.34	2812	4 5 .		
20	47.09	173	1.2	2666	5 0 .		
17	53.54	197	1.04	2423	5 6 .		

NOTE

Other output speeds are available using 2 and 8 pole motors - Consult Application Engineering

SERIES M

SELECTION TABLES

GEARED MOTORS

0.37 kW

6 POLE

N2 R/MIN	i	M2 Nm	Fm	N	Unit Designation	Kg	Motor Size
Output Speed	Ratio	Output Torque	Service Factor	Overhung Load	Column Entry [1] Through [20] Spaces to be filled when entering order	Weight	
16	57.03	208	1	2186	M 0 3 3 2 5 6 . _ M _ _ _ _ . 3 7 C - -	23.5	80A
15	62.87	230	0.91	1945	6 3 .		
13	69.19	252	0.83	1674	7 1 .		
34	27.3	101	3.34	7200	M 0 4 2 2 2 8 . _ M _ _ _ _ . 3 7 C - -	30.5	80A
29	32.19	119	2.82	7200	3 2 .		
26	35.25	130	2.58	7200	3 6 .		
21	43.2	159	2.11	7200	4 5 .		
19	48.15	178	1.9	7200	5 0 .		
17	54	199	1.35	7200	5 6 .		
16	58.38	214	1.58	6045	M 0 4 3 2 5 6 . _ M _ _ _ _ . 3 7 C - -	32.5	80A
14	64.29	235	1.43	6506	6 3 .		
12	73.95	271	1.25	5976	7 1 .		
11	80.4	294	1.15	5626	8 0 .		
10	96.52	353	0.96	5597	1 0 0		
29	32.19	119	3.76	7200	M 0 5 2 2 3 2 . _ M _ _ _ _ . 3 7 C - -	31.5	80A
26	35.25	130	3.44	7200	3 6 .		
21	43.2	160	2.54	7200	4 5 .		
19	48.15	178	2.13	7200	5 0 .		
17	54	199	1.35	7200	5 6 .		
16	58.38	214	2.1	6391	M 0 5 3 2 5 6 . _ M _ _ _ _ . 3 7 C - -	32.5	80A
14	64.29	236	1.9	6204	6 3 .		
12	73.95	271	1.66	5713	7 1 .		
11	80.4	295	1.52	5556	8 0 .		
10	96.52	353	1.27	4800	1 0 0		
7.9	115.82	423	1.06	4339	1 1 2		
7	130.5	477	0.94	3513	1 2 5		
6.1	151.71	555	0.81	3013	1 6 0		
15	59.61	220	2.13	7200	M 0 6 2 2 5 6 . _ M _ _ _ _ . 3 7 C - -	36.5	80A
13	72.28	265	2.36	7200	M 0 6 3 2 6 3 . _ M _ _ _ _ . 3 7 C - -	37.5	80A
12	79.6	292	2.14	7008	7 1 .		
10	91.56	336	1.86	6645	8 0 .		
9.2	99.54	365	1.71	6403	1 0 0		
7.7	119.5	438	1.43	6626	1 1 2		
6.4	143.39	525	1.19	5470	1 2 5		
5.7	161.57	590	1.06	6424	1 6 0		
4.9	187.83	688	0.91	4961	1 8 0		
4.3	213.18	779	0.8	3099	2 0 0		
4.3	215.23	773	0.81	7200	M 0 6 4 2 2 2 5 _ M _ _ _ _ . 3 7 C - -	50.5	80A
16	58.95	216	3.99	10000	M 0 7 3 2 5 6 . _ M _ _ _ _ . 3 7 C - -	48.5	80A
15	62.83	231	3.76	10000	6 3 .		
12	74.47	274	3.16	10000	7 1 .		
12	79.51	291	2.98	10000	8 0 .		
9.3	98.66	361	2.4	10000	1 0 0		
7.9	116.34	426	2.04	10000	1 1 2		
7.2	127.39	466	1.86	10000	1 2 5		
5.9	156.12	569	1.54	10000	1 6 0		
5.3	174.01	635	1.39	8970	1 8 0		
4.7	195.15	711	1.25	7760	2 0 0		
4	229	821	1.06	4677	M 0 7 4 2 2 2 5 _ M _ _ _ _ . 3 7 C - -	57.5	80A
3.5	259.68	929	0.93	4676	2 5 0		
3.2	286.42	1025	0.85	4676	2 8 0		
4	228.91	821	1.66	18916	M 0 8 4 2 2 2 5 _ M _ _ _ _ . 3 7 C - -	105.5	80A
3.6	258.98	928	1.58	17870	2 5 0		
3.1	301.21	1079	1.36	17870	2 8 0		
2.7	337.01	1206	1.21	17870	3 0 0		
2.6	359.19	1286	1.14	17870	3 6 0		
2.2	425.69	1523	0.96	17870	4 0 0		
1.9	480.51	1717	0.9	16792	4 5 0		
1.8	513.04	1833	0.84	16792	5 0 0		
4	231.06	837	3.16	25710	M 0 9 4 1 2 2 5 _ M _ _ _ _ . 3 7 C - -	149.5	80A
3.6	258.09	933	3.06	24951	2 5 0		
3.1	300.18	1085	2.63	24951	2 8 0		
2.7	335.85	1212	2.36	24951	3 0 0		
2.6	357.95	1293	2.21	24951	3 6 0		
2.2	424.23	1531	1.87	24951	4 0 0		
2	471.32	1699	1.68	24951	4 5 0		
1.8	503.22	1813	1.58	24951	5 0 0		
1.5	624.45	2246	1.27	24951	6 5 0		
1.2	736.35	2644	1.08	24951	7 3 0		
1	882.06	3161	0.9	24951	8 6 0		
0.34	2743.72	9589	1.11	80613	M 1 4 5 1 2 7 C _ M _ _ _ _ . 3 7 C - -	406.5	80A
0.27	3404.7	11873	0.9	80613	3 2 C		

NOTE
Other output speeds are available using 2 and 8 pole motors - Consult Application Engineering

SERIES M

SELECTION TABLES

GEARED MOTORS

0.55 kW

4 POLE

N2 R/MIN	i	M2 Nm	Fm	N	Unit Designation	Kg	Motor Size
Output Speed	Ratio	Output Torque	Service Factor	Overhung Load	Column Entry 1 Through 20 Spaces to be filled when entering order	Weight	
379	3.75	13	4.43	1625	M 0 1 2 2 3 . 6 _ M _ _ _ _ . 5 5 A - -	18.5	80A
280	5.07	18	3.72	1705	5 . 0		
246	5.76	20	3.47	1740	5 . 6		
218	6.53	23	3.21	1711	6 . 3		
170	8.35	29	2.65	1706	8 . 0		
158	9	32	2.49	1703	9 . 0		
125	11.36	40	2.07	1720	1 1 .		
110	12.88	46	1.89	1720	1 2 .		
97	14.71	52	1.7	1570	1 4 .		
87	16.37	58	1.54	1831	1 6 .		
79	18.05	64	1.39	1736	1 8 .		
71	19.86	70	1.27	1558	2 0 .		
61	23.27	82	1.08	1770	2 2 .		
51	27.92	99	0.9	1320	2 8 .		
127	11.15	39	3.63	4000	M 0 2 2 2 1 1 _ M _ _ _ _ . 5 5 A - -	22.5	80A
115	12.37	44	3.35	4000	1 2 .		
101	14.05	50	3.04	4000	1 4 .		
89	15.97	57	2.8	4000	1 6 .		
81	17.58	62	2.55	3942	1 8 .		
70	20.23	72	2.21	3885	2 0 .		
65	21.99	78	2.03	4000	2 2 .		
54	26.4	94	1.7	3908	2 8 .		
45	31.68	112	1.42	4000	3 2 .		
40	35.69	126	1.26	4000	3 6 .		
34	41.49	147	1.08	4000	4 5 .		
30	47.09	167	0.95	4000	5 0 .		
27	53.54	190	0.84	3690	5 6 .		
101	14.05	50	3.85	4000	M 0 3 2 2 1 4 _ M _ _ _ _ . 5 5 A - -	22.5	80A
89	15.97	56	3.6	3972	1 6 .		
81	17.58	62	3.31	3934	1 8 .		
70	20.23	72	2.88	3798	2 0 .		
65	21.99	78	2.65	3719	2 2 .		
54	26.4	93	2.23	3380	2 8 .		
45	31.68	112	1.85	3469	3 2 .		
40	35.69	127	1.65	3143	3 6 .		
34	41.49	148	1.34	3584	4 5 .		
30	47.09	167	1.21	3091	5 0 .		
27	53.54	190	1.08	3690	5 6 .		
25	57.03	200	1.04	3390	M 0 3 3 2 5 6 _ M _ _ _ _ . 5 5 A - -	23.5	80A
23	62.87	221	0.94	2800	6 3 .		
21	69.19	243	0.86	2160	7 1 .		
52	27.3	97	3.44	7200	M 0 4 2 2 2 8 _ M _ _ _ _ . 5 5 A - -	30.5	80A
44	32.19	115	2.94	7200	3 2 .		
40	35.25	125	2.69	7200	3 6 .		
33	43.2	154	2.19	7200	4 5 .		
29	48.15	171	1.98	7200	5 0 .		
26	54	191	1.41	7200	5 6 .		
24	58.38	205	1.64	6917	M 0 4 3 2 5 6 _ M _ _ _ _ . 5 5 A - -	32.5	80A
22	64.29	227	1.49	7200	6 3 .		
19	73.95	261	1.29	7154	7 1 .		
18	80.4	283	1.19	7050	8 0 .		
15	96.52	340	0.99	7200	1 0 0		
12	115.82	407	0.83	6500	1 1 2		
44	32.19	115	3.9	7200	M 0 5 2 2 3 2 _ M _ _ _ _ . 5 5 A - -	31.5	80A
40	35.25	125	3.58	7200	3 6 .		
33	43.2	154	2.3	7200	4 5 .		
29	48.15	171	2.12	7200	5 0 .		
26	54	191	1.41	7200	5 6 .		
24	58.38	207	2.17	6869	M 0 5 3 2 5 6 _ M _ _ _ _ . 5 5 A - -	32.5	80A
22	64.29	227	1.98	6652	6 3 .		
19	73.95	261	1.72	5918	7 1 .		
18	80.4	284	1.58	6714	8 0 .		
15	96.52	340	1.32	5629	1 0 0		
12	115.82	408	1.1	5960	1 1 2		
11	130.5	459	0.98	4900	1 2 5		
9.4	151.71	534	0.84	3329	1 6 0		
27	53.49	190	2.76	7200	M 0 6 2 2 5 0 _ M _ _ _ _ . 5 5 A - -	36.5	80A
24	59.61	212	2.21	7200	5 6 .		
20	72.28	254	2.46	7200	M 0 6 3 2 6 3 _ M _ _ _ _ . 5 5 A - -	37.5	80A
18	79.6	282	2.21	7200	7 1 .		
16	91.56	322	1.94	7200	8 0 .		
14	99.54	351	1.78	7200	1 0 0		
12	119.5	422	1.48	7200	1 1 2		
10	143.39	505	1.24	7200	1 2 5		
8.8	161.57	568	1.1	7200	1 6 0		
7.6	187.83	662	0.95	7200	1 8 0		
6.7	213.18	751	0.83	7200	2 0 0		
6.6	215.23	743	0.84	7200	M 0 6 4 2 2 2 5 _ M _ _ _ _ . 5 5 A - -	50.5	80A

NOTE
Other output speeds are available using 2 and 8 pole motors - Consult Application Engineering

SERIES M

SELECTION TABLES

GEARED MOTORS

0.55 kW

4 POLE

N2 R/MIN	i	M2 Nm	Fm	N	Unit Designation	Kg	Motor Size
Output Speed	Ratio	Output Torque	Service Factor	Overhung Load	Column Entry [1] Through [20] Spaces to be filled when entering order	Weight	
24	58.95	208	3.61	10000	M 0 7 3 2 5 6 . _ M _ _ _ _ . 5 5 A - -	48.5	80A
23	62.83	221	3.47	10000	6 3 .		
19	74.47	263	3.1	10000	7 1 .		
18	79.51	280	2.97	10000	8 0 .		
14	98.66	348	2.49	10000	1 0 0		
12	116.34	409	2.12	10000	1 1 2		
11	127.39	447	1.94	10000	1 2 5		
9.1	156.12	548	1.58	10000	1 6 0		
8.2	174.01	611	1.42	9140	1 8 0		
7.3	195.15	684	1.27	7940	2 0 0		
6.2	229	790	1.1	4677	M 0 7 4 2 2 2 5 _ M _ _ _ _ . 5 5 A - -	57.5	80A
5.5	259.68	894	0.97	4676	2 5 0		
5	286.42	986	0.88	4676	2 8 0		
12	119.19	419	3.94	20000	M 0 8 3 2 1 1 2 _ M _ _ _ _ . 5 5 A - -	76.5	80A
11	130.92	461	3.58	20000	1 2 5		
8.9	160.45	565	2.92	20000	1 6 0		
8.1	175.21	617	2.67	20000	1 8 0		
7	201.75	707	2.33	20000	2 0 0		
6.2	228.91	788	1.73	18916	M 0 8 4 2 2 2 5 _ M _ _ _ _ . 5 5 A - -	105.5	80A
5.5	258.98	891	1.64	17870	2 5 0		
4.7	301.21	1036	1.41	17870	2 8 0		
4.2	337.01	1158	1.26	17870	3 0 0		
4	359.19	1235	1.18	17870	3 6 0		
3.3	425.69	1464	1	17870	4 0 0		
3	480.51	1650	0.93	16792	4 5 0		
2.8	513.04	1761	0.87	16792	5 0 0		
6.1	231.06	805	3.29	25710	M 0 9 4 1 2 2 5 _ M _ _ _ _ . 5 5 A - -	149.5	80A
5.5	258.09	898	3.18	24951	2 5 0		
4.7	300.18	1044	2.74	24951	2 8 0		
4.2	335.85	1166	2.45	24951	3 0 0		
4	357.95	1244	2.3	24951	3 6 0		
3.3	424.23	1473	1.94	24951	4 0 0		
3	471.32	1635	1.75	24951	4 5 0		
2.8	503.22	1745	1.64	24951	5 0 0		
2.3	624.45	2162	1.32	24951	6 5 0		
1.9	736.35	2546	1.12	24951	7 3 0		
1.6	882.06	3040	0.94	24951	8 6 0		
0.52	2743.72	9227	1.15	80613	M 1 4 5 1 2 7 C _ M _ _ _ _ . 5 5 A - -	406.5	80A
0.42	3404.7	11435	0.93	80613	3 2 C		

0.55 kW

6 POLE

245	3.75	20	3.29	1673	M 0 1 2 2 3 . 6 _ M _ _ _ _ . 5 5 C - -	20	80B
182	5.07	28	2.7	1720	5 . 0		
160	5.76	31	2.46	1715	5 . 6		
141	6.53	36	2.21	1720	6 . 3		
110	8.35	46	1.85	1720	8 . 0		
102	9	49	1.74	1671	9 . 0		
81	11.36	62	1.43	1341	1 1 .		
71	12.88	71	1.26	1129	1 2 .		
63	14.71	81	1.1	1066	1 4 .		
56	16.37	90	0.99	1083	1 6 .		
51	18.05	99	0.9	830	1 8 .		
46	19.86	109	0.82	603	2 0 .		
146	6.3	34	3.96	4000	M 0 2 2 2 6 . 3 _ M _ _ _ _ . 5 5 C - -	24	80B
115	8	44	3.28	4000	8 . 0		
101	9.09	50	2.98	4000	9 . 0		
82	11.15	62	2.54	4000	1 1 .		
74	12.37	68	2.33	4000	1 2 .		
65	14.05	77	2.06	4000	1 4 .		
58	15.97	88	1.81	4000	1 6 .		
52	17.58	97	1.64	3921	1 8 .		
45	20.23	111	1.43	3604	2 0 .		
42	21.99	121	1.32	3414	2 2 .		
35	26.4	145	1.1	2793	2 8 .		
29	31.68	174	0.92	3013	3 2 .		
26	35.69	196	0.82	2481	3 6 .		
101	9.09	50	3.78	4000	M 0 3 2 2 9 . 0 _ M _ _ _ _ . 5 5 C - -	24	80B
82	11.15	61	3.29	4000	1 1 .		
74	12.37	68	3.05	4000	1 2 .		
65	14.05	77	2.68	4000	1 4 .		
58	15.97	88	2.37	4000	1 6 .		
52	17.58	97	2.14	3871	1 8 .		
45	20.23	112	1.86	3549	2 0 .		
42	21.99	121	1.72	3332	2 2 .		
35	26.4	145	1.44	2793	2 8 .		
29	31.68	174	1.2	2391	3 2 .		
26	35.69	195	1.07	2391	3 6 .		
22	41.49	228	0.9	1687	4 5 .		
20	47.09	258	0.81	1403	5 0 .		

NOTE

Other output speeds are available using 2 and 8 pole motors - Consult Application Engineering

SERIES M

SELECTION TABLES

GEARED MOTORS

0.55 kW

6 POLE

N2 R/MIN	i	M2 Nm	Fm	N	Unit Designation	Kg	Motor Size
Output Speed	Ratio	Output Torque	Service Factor	Overhung Load	Column Entry 1 Through 20 Spaces to be filled when entering order	Weight	
53	17.39	96	3.5	7200	M 0 4 2 2 1 8 . _ M _ _ _ _ . 5 5 C - -	32	80B
45	20.61	114	2.96	7200	2 0 .		
42	22	122	2.77	7200	2 2 .		
34	27.3	150	2.25	6720	2 8 .		
29	32.19	177	1.9	6835	3 2 .		
26	35.25	194	1.74	6675	3 6 .		
21	43.2	237	1.42	6266	4 5 .		
19	48.15	264	1.28	6393	5 0 .		
17	54	296	0.91	6939	5 6 .		
16	58.38	318	1.06	4951	M 0 4 3 2 5 6 . _ M _ _ _ _ . 5 5 C - -	34	80B
14	64.29	350	0.96	5849	6 3 .		
12	73.95	403	0.84	4817	7 1 .		
45	20.61	114	3.94	6989	M 0 5 2 2 2 0 . _ M _ _ _ _ . 5 5 C - -	33	80B
42	22	121	3.69	6929	2 2 .		
34	27.3	151	2.98	6700	2 8 .		
29	32.19	178	2.53	6491	3 2 .		
26	35.25	194	2.32	6491	3 6 .		
21	43.2	237	1.71	6249	4 5 .		
19	48.15	264	1.43	6053	5 0 .		
17	54	296	0.91	6678	5 6 .		
16	58.38	318	1.41	5177	M 0 5 3 2 5 6 . _ M _ _ _ _ . 5 5 C - -	34	80B
14	64.29	351	1.28	4710	6 3 .		
12	73.95	404	1.11	4304	7 1 .		
11	80.4	439	1.02	3999	8 0 .		
10	96.52	525	0.86	2526	1 0 0		
27	33.8	187	3.35	7200	M 0 6 2 2 3 2 . _ M _ _ _ _ . 5 5 C - -	38	80B
23	39.86	220	2.84	7200	3 6 .		
21	43.64	241	2.6	7200	4 5 .		
17	53.49	294	1.85	7200	5 0 .		
15	59.61	328	1.43	6908	5 6 .		
13	72.28	394	1.59	7200	M 0 6 3 2 6 3 . _ M _ _ _ _ . 5 5 C - -	39	80B
12	79.6	435	1.44	6720	7 1 .		
10	91.56	500	1.25	5812	8 0 .		
9.2	99.54	543	1.15	5209	1 0 0		
7.7	119.5	652	0.96	6083	1 1 2		
6.4	143.39	781	0.8	3831	1 2 5		
22	42.21	231	3.75	10000	M 0 7 2 2 4 5 . _ M _ _ _ _ . 5 5 C - -	45	80B
19	48.56	266	2.63	10000	5 0 .		
17	53.96	294	2.02	10000	5 6 .		
16	58.95	322	2.68	9221	M 0 7 3 2 5 6 . _ M _ _ _ _ . 5 5 C - -	50	80B
15	62.83	343	2.53	9072	6 3 .		
12	74.47	408	2.13	8636	7 1 .		
12	79.51	433	2	8446	8 0 .		
9.3	98.66	537	1.61	8407	1 0 0		
7.9	116.34	633	1.37	7534	1 1 2		
7.2	127.39	693	1.25	7534	1 2 5		
5.9	156.12	846	1.03	5591	1 6 0		
5.3	174.01	945	0.94	4721	1 8 0		
4.7	195.15	1057	0.84	4084	2 0 0		
9	102.2	557	2.96	20000	M 0 8 3 2 1 0 0 _ M _ _ _ _ . 5 5 C - -	78	80B
7.7	119.19	648	2.54	20000	1 1 2		
7	130.92	711	2.32	20000	1 2 5		
5.7	160.45	876	1.88	20000	1 6 0		
5.3	175.21	952	1.73	20000	1 8 0		
4.6	201.75	1093	1.51	20000	2 0 0		
4	228.91	1221	1.12	18916	M 0 8 4 2 2 2 5 _ M _ _ _ _ . 5 5 C - -	107	80B
3.6	258.98	1380	1.06	17870	2 5 0		
3.1	301.21	1604	0.91	17870	2 8 0		
2.7	337.01	1792	0.82	17870	3 0 0		
6.3	145.2	791	3.12	29600	M 0 9 3 1 1 4 0 _ M _ _ _ _ . 5 5 C - -	129	80B
5.7	160.29	875	2.82	29500	1 6 0		
4	231.06	1244	2.13	25710	M 0 9 4 1 2 2 5 _ M _ _ _ _ . 5 5 C - -	151	80B
3.6	258.09	1388	2.06	24951	2 5 0		
3.1	300.18	1613	1.77	24951	2 8 0		
2.7	335.85	1802	1.59	24951	3 0 0		
2.6	357.95	1922	1.49	24951	3 6 0		
2.2	424.23	2275	1.26	24951	4 0 0		
2	471.32	2525	1.13	24951	4 5 0		
1.8	503.22	2695	1.06	24951	5 0 0		
1.5	624.45	3339	0.86	24951	6 5 0		

NOTE
Other output speeds are available using 2 and 8 pole motors - Consult Application Engineering

SERIES M

SELECTION TABLES

GEARED MOTORS

0.55 kW

6 POLE

N2 R/MIN	i	M2 Nm	Fm	N	Unit Designation	Kg	Motor Size
Output Speed	Ratio	Output Torque	Service Factor	Overhung Load	Column Entry [1] Through [20] Spaces to be filled when entering order	Weight	
4.2	220.22	1179	3.74	41580	M 1 0 4 1 2 2 5 _ M _ _ _ _ . 5 5 C - -	213	80B
3.8	242.24	1297	3.4	41580	2 5 0		
3.3	278.36	1489	2.96	41580	2 8 0		
2.9	315.65	1686	2.62	41580	3 0 0		
2.6	348.16	1861	2.37	41580	3 6 0		
2.3	398.71	2130	2.07	41580	4 0 0		
2.1	443.06	2364	1.87	41580	4 5 0		
1.8	500.94	2670	1.65	41580	5 0 0		
1.6	580.78	3093	1.43	41580	6 5 0		
1.3	692.72	3683	1.2	41580	7 3 0		
1.1	828.21	4397	1	41580	8 6 0		
0.93	987.84	5238	0.84	41580	1 0 C		
2.8	325.33	1733	3.66	64632	M 1 3 4 1 3 0 0 _ M _ _ _ _ . 5 5 C - -	287	80B
2.6	358.84	1912	3.32	64632	3 6 0		
2.2	410.95	2189	2.9	64632	4 0 0		
2	463.22	2466	2.57	64632	4 5 0		
1.8	523.74	2786	2.28	64632	5 0 0		
1.5	607.22	3226	1.97	64632	6 5 0		
1.3	724.25	3842	1.65	64632	7 3 0		
1.1	858.69	4535	1.4	64632	8 6 0		
0.9	1024.19	5402	1.18	64632	1 0 C		
0.81	1140.7	6006	1.06	64632	1 1 C		
0.74	1249.19	6571	0.97	64632	1 3 C		
0.6	1528.11	8013	0.81	64690	1 5 C		
1.7	556.83	2961	3.64	80613	M 1 4 4 1 5 0 0 _ M _ _ _ _ . 5 5 C - -	403	80B
1.4	645.58	3429	3.14	80613	6 5 0		
1.2	770.01	4083	2.64	80613	7 3 0		
1.1	801.52	4244	2.51	80613	8 6 0		
0.99	929.27	4915	2.17	80613	1 0 C		
0.83	1108.37	5853	1.82	80613	1 1 C		
0.76	1213.79	6404	1.66	80613	1 3 C		
0.61	1502.21	7906	1.28	80711	1 5 C		
0.51	1802.65	9464	1.07	80711	1 8 C		
0.44	2074.02	10876	0.93	80711	2 0 C		
0.4	2304.47	12062	0.84	80711	2 4 C		

0.75 kW

4 POLE

377	3.75	18	3.24	1596	M 0 1 2 2 3 . 6 _ M _ _ _ _ . 7 5 A - -	18.5	80A
279	5.07	24	2.72	1665	5 . 0		
246	5.76	28	2.54	1694	5 . 6		
217	6.53	32	2.34	1633	6 . 3		
169	8.35	40	1.94	1616	8 . 0		
157	9	44	1.82	1612	9 . 0		
125	11.36	55	1.51	1636	1 1 .		
110	12.88	63	1.38	1636	1 2 .		
96	14.71	72	1.25	1417	1 4 .		
86	16.37	79	1.12	1800	1 6 .		
78	18.05	88	1.02	1660	1 8 .		
71	19.86	96	0.93	1400	2 0 .		
177	8	39	3.47	4000	M 0 2 2 2 8 . 0 _ M _ _ _ _ . 7 5 A - -	22.5	80A
156	9.09	44	3.14	4000	9 . 0		
127	11.15	54	2.65	4000	1 1 .		
114	12.37	60	2.45	4000	1 2 .		
101	14.05	68	2.22	4000	1 4 .		
89	15.97	78	2.04	3968	1 6 .		
80	17.58	85	1.86	3878	1 8 .		
70	20.23	99	1.61	3757	2 0 .		
64	21.99	107	1.48	4000	2 2 .		
54	26.4	128	1.24	3847	2 8 .		
45	31.68	154	1.04	4000	3 2 .		
40	35.69	173	0.92	4000	3 6 .		
156	9.09	44	3.76	4000	M 0 3 2 2 9 . 0 _ M _ _ _ _ . 7 5 A - -	22.5	80A
127	11.15	54	3.28	4000	1 1 .		
114	12.37	60	3.07	4000	1 2 .		
101	14.05	69	2.81	4000	1 4 .		
89	15.97	77	2.63	3957	1 6 .		
80	17.58	85	2.42	3898	1 8 .		
70	20.23	99	2.11	3689	2 0 .		
64	21.99	107	1.94	3568	2 2 .		
54	26.4	128	1.63	3045	2 8 .		
45	31.68	154	1.35	3182	3 2 .		
40	35.69	173	1.2	2680	3 6 .		
34	41.49	202	0.98	3360	4 5 .		
30	47.09	229	0.88	2600	5 0 .		

NOTE

Other output speeds are available using 2 and 8 pole motors - Consult Application Engineering

SERIES M

SELECTION TABLES

GEARED MOTORS

0.75kW

4 POLE

N2 R/MIN	i	M2 Nm	Fm	N	Unit Designation	Kg	Motor Size
Output Speed	Ratio	Output Torque	Service Factor	Overhung Load	Column Entry <input type="text" value="1"/> Through <input type="text" value="20"/> Spaces to be filled when entering order	Weight	
81	17.39	85	3.64	6430	M 0 4 2 2 1 8 . _ M _ _ _ _ . 7 5 A - -	30.5	80A
69	20.61	100	3.16	6750	2 0 .		
64	22	107	2.99	6880	2 2 .		
52	27.3	133	2.51	7052	2 8 .		
44	32.19	157	2.15	7124	3 2 .		
40	35.25	172	1.96	7147	3 6 .		
33	43.2	211	1.6	6970	4 5 .		
29	48.15	234	1.44	7178	5 0 .		
26	54	262	1.03	7200	5 6 .		
24	58.38	281	1.2	6729	M 0 4 3 2 5 6 . _ M _ _ _ _ . 7 5 A - -	32.5	80A
22	64.29	310	1.09	7200	6 3 .		
19	73.95	357	0.95	7130	7 1 .		
18	80.4	388	0.87	6970	8 0 .		
52	27.3	134	3.36	6723	M 0 5 2 2 2 8 . _ M _ _ _ _ . 7 5 A - -	31.5	80A
44	32.19	157	2.85	6875	3 2 .		
40	35.25	172	2.62	6769	3 6 .		
33	43.2	210	1.68	6865	4 5 .		
29	48.15	234	1.55	6658	5 0 .		
26	54	262	1.03	7200	5 6 .		
24	58.38	283	1.59	6502	M 0 5 3 2 5 6 . _ M _ _ _ _ . 7 5 A - -	32.5	80A
22	64.29	311	1.44	6044	6 3 .		
19	73.95	358	1.26	5064	7 1 .		
18	80.4	389	1.16	6390	8 0 .		
15	96.52	466	0.97	4780	1 0 0		
42	33.8	165	3.77	7200	M 0 6 2 2 3 2 . _ M _ _ _ _ . 7 5 A - -	36.5	80A
36	39.86	194	3.21	7200	3 6 .		
32	43.64	213	2.93	7200	4 5 .		
26	53.49	260	2.02	7200	5 0 .		
24	59.61	291	1.61	7200	5 6 .		
20	72.28	348	1.8	7200	M 0 6 3 2 6 3 . _ M _ _ _ _ . 7 5 A - -	37.5	80A
18	79.6	386	1.61	7200	7 1 .		
15	91.56	441	1.42	7200	8 0 .		
14	99.54	481	1.3	7200	1 0 0		
12	119.5	577	1.08	7200	1 1 2		
10	143.39	691	0.91	7200	1 2 5		
29	48.56	235	2.97	10000	M 0 7 2 2 5 0 . _ M _ _ _ _ . 7 5 A - -	43.5	80A
26	53.96	261	2.28	10000	5 6 .		
24	58.95	285	2.64	9458	M 0 7 3 2 5 6 . _ M _ _ _ _ . 7 5 A - -	48.5	80A
23	62.83	303	2.54	9349	6 3 .		
19	74.47	359	2.26	9454	7 1 .		
18	79.51	383	2.17	9288	8 0 .		
14	98.66	476	1.82	8661	1 0 0		
12	116.34	560	1.55	8450	1 1 2		
11	127.39	612	1.42	7996	1 2 5		
9.1	156.12	751	1.16	6910	1 6 0		
8.1	174.01	837	1.04	5530	1 8 0		
7.3	195.15	936	0.93	3899	2 0 0		
6.2	229	1081	0.8	4677	M 0 7 4 2 2 2 5 _ M _ _ _ _ . 7 5 A - -	57.5	80A
14	102.2	493	3.34	20000	M 0 8 3 2 1 0 0 _ M _ _ _ _ . 7 5 A - -	76.5	80A
12	119.19	573	2.88	19337	1 1 2		
11	130.92	630	2.62	19051	1 2 5		
8.8	160.45	773	2.13	19410	1 6 0		
8.1	175.21	845	1.95	18989	1 8 0		
7	201.75	968	1.7	18252	2 0 0		
6.2	228.91	1079	1.27	18916	M 0 8 4 2 2 2 5 _ M _ _ _ _ . 7 5 A - -	105.5	80A
5.5	258.98	1219	1.2	17870	2 5 0		
4.7	301.21	1418	1.03	17870	2 8 0		
4.2	337.01	1585	0.92	17870	3 0 0		
3.9	359.19	1691	0.87	17870	3 6 0		
10	145.2	700	3.53	29600	M 0 9 3 1 1 4 0 _ M _ _ _ _ . 7 5 A - -	127.5	80A
8.8	160.29	771	3.2	29600	1 6 0		
6.1	231.06	1101	2.4	25710	M 0 9 4 1 2 2 5 _ M _ _ _ _ . 7 5 A - -	149.5	80A
5.5	258.09	1228	2.33	24951	2 5 0		
4.7	300.18	1428	2	24951	2 8 0		
4.2	335.85	1596	1.79	24951	3 0 0		
4	357.95	1702	1.68	24951	3 6 0		
3.3	424.23	2016	1.42	24951	4 0 0		
3	471.32	2237	1.28	24951	4 5 0		
2.8	503.22	2388	1.2	24951	5 0 0		
2.3	624.45	2959	0.97	24951	6 5 0		
1.9	736.35	3485	0.82	24951	7 3 0		

NOTE
Other output speeds are available using 2 and 8 pole motors - Consult Application Engineering

SERIES M

SELECTION TABLES

GEARED MOTORS

0.75 kW

4 POLE

N2 R/MIN	i	M2 Nm	Fm	N	Unit Designation	Kg	Motor Size
Output Speed	Ratio	Output Torque	Service Factor	Overhung Load	Column Entry [1] Through [20] Spaces to be filled when entering order	Weight	
5.8	242.24	1148	3.84	41580	M 1 0 4 1 2 5 0 _ M _ _ _ _ . 7 5 A - -	211.5	80A
5.1	278.36	1318	3.35	41580	2 8 0		
4.5	315.65	1493	2.95	41580	3 0 0		
4.1	348.16	1648	2.68	41580	3 6 0		
3.5	398.71	1886	2.34	41580	4 0 0		
3.2	443.06	2093	2.11	41580	4 5 0		
2.8	500.94	2365	1.87	41580	5 0 0		
2.4	580.78	2740	1.61	41580	6 5 0		
2	692.72	3264	1.35	41580	7 3 0		
1.7	828.21	3892	1.13	41580	8 6 0		
1.4	987.84	4638	0.95	41580	1 0 C		
1.2	1138.21	5332	0.83	41580	1 1 C		
3.9	358.84	1694	3.75	64632	M 1 3 4 1 3 6 0 _ M _ _ _ _ . 7 5 A - -	285.5	80A
3.4	410.95	1939	3.27	64632	4 0 0		
3.1	463.22	2185	2.91	64632	4 5 0		
2.7	523.74	2468	2.57	64632	5 0 0		
2.3	607.22	2859	2.22	64632	6 5 0		
2	724.25	3406	1.86	64632	7 3 0		
1.6	858.69	4016	1.58	64632	8 6 0		
1.4	1024.19	4785	1.33	64632	1 0 C		
1.2	1140.7	5319	1.19	64632	1 1 C		
1.1	1249.19	5821	1.09	64632	1 3 C		
0.93	1528.11	7097	0.91	64690	1 5 C		
2.2	645.58	3040	3.54	80613	M 1 4 4 1 6 5 0 _ M _ _ _ _ . 7 5 A - -	401.5	80A
1.8	770.01	3621	2.97	80613	7 3 0		
1.8	801.52	3760	2.83	80613	8 6 0		
1.5	929.27	4355	2.45	80613	1 0 C		
1.3	1108.37	5188	2.05	80613	1 1 C		
1.2	1213.79	5677	1.88	80613	1 3 C		
0.94	1502.21	7007	1.44	80711	1 5 C		
0.78	1802.65	8391	1.2	80711	1 8 C		
0.68	2074.02	9645	1.05	80711	2 0 C		
0.61	2304.47	10700	0.94	80711	2 4 C		
0.52	2743.72	12627	0.84	80613	M 1 4 5 1 2 7 C _ M _ _ _ _ . 7 5 A - -	406.5	80A

0.75 kW

6 POLE

245	3.75	28	2.41	1610	M 0 1 2 2 3 . 6 _ M _ _ _ _ . 7 5 C - -	23.5	90S
182	5.07	38	1.98	1636	5 . 0		
160	5.76	43	1.8	1630	5 . 6		
141	6.53	49	1.62	1636	6 . 3		
110	8.35	62	1.35	1636	8 . 0		
102	9	67	1.28	1565	9 . 0		
81	11.36	85	1.05	1081	1 1 .		
71	12.88	96	0.93	770	1 2 .		
63	14.71	110	0.81	678	1 4 .		
183	5.03	37	3.45	4000	M 0 2 2 2 5 . 0 _ M _ _ _ _ . 7 5 C - -	26.5	90S
166	5.55	41	3.19	4000	5 . 6		
146	6.3	47	2.9	4000	6 . 3		
115	8	60	2.4	4000	8 . 0		
101	9.09	68	2.18	4000	9 . 0		
82	11.15	84	1.87	4000	1 1 .		
74	12.37	93	1.71	4000	1 2 .		
65	14.05	106	1.51	4000	1 4 .		
58	15.97	120	1.33	4000	1 6 .		
52	17.58	132	1.21	3833	1 8 .		
45	20.23	152	1.05	3341	2 0 .		
42	21.99	165	0.97	3023	2 2 .		
35	26.4	198	0.81	2141	2 8 .		
166	5.55	41	3.8	4000	M 0 3 2 2 5 . 6 _ M _ _ _ _ . 7 5 C - -	26.5	90S
146	6.3	47	3.5	4000	6 . 3		
115	8	60	3.02	4000	8 . 0		
101	9.09	68	2.77	4000	9 . 0		
82	11.15	84	2.41	4000	1 1 .		
74	12.37	93	2.24	4000	1 2 .		
65	14.05	106	1.97	4000	1 4 .		
58	15.97	120	1.74	4000	1 6 .		
52	17.58	132	1.57	3801	1 8 .		
45	20.23	152	1.37	3306	2 0 .		
42	21.99	165	1.26	2971	2 2 .		
35	26.4	198	1.05	2141	2 8 .		
29	31.68	237	0.88	1521	3 2 .		
73	12.54	94	3.44	6590	M 0 4 2 2 1 2 . _ M _ _ _ _ . 7 5 C - -	35.5	90S
63	14.58	110	3.07	6880	1 4 .		
56	16.31	123	2.75	7100	1 6 .		
53	17.39	131	2.57	7050	1 8 .		
45	20.61	155	2.17	6996	2 0 .		
42	22	166	2.03	6915	2 2 .		
34	27.3	205	1.65	6186	2 8 .		
29	32.19	242	1.39	6429	3 2 .		
26	35.25	265	1.28	6093	3 6 .		
21	43.2	324	1.04	5229	4 5 .		
19	48.15	360	0.94	5497	5 0 .		

NOTE

Other output speeds are available using 2 and 8 pole motors - Consult Application Engineering

SERIES M

SELECTION TABLES

GEARED MOTORS

0.75 kW

6 POLE

N2 R/MIN	i	M2 Nm	Fm	N	Unit Designation	Kg	Motor Size
Output Speed	Ratio	Output Torque	Service Factor	Overhung Load	Column Entry 1 Through 20 Spaces to be filled when entering order	Weight	
56	16.31	123	3.65	6381	M 0 5 2 2 1 6 . _ M _ _ _ _ . 7 5 C - -	36.5	90S
53	17.39	131	3.42	6708	1 8 .		
45	20.61	155	2.89	6755	2 0 .		
42	22	166	2.71	6628	2 2 .		
34	27.3	205	2.18	6145	2 8 .		
29	32.19	242	1.85	5704	3 2 .		
26	35.25	264	1.7	5704	3 6 .		
21	43.2	324	1.25	5192	4 5 .		
19	48.15	360	1.05	4778	5 0 .		
16	58.38	434	1.03	3829	M 0 5 3 2 5 6 . _ M _ _ _ _ . 7 5 C - -	37.5	90S
14	64.29	479	0.94	3050	6 3 .		
12	73.95	551	0.82	2739	7 1 .		
36	25.51	192	3.25	7200	M 0 6 2 2 2 2 . _ M _ _ _ _ . 7 5 C - -	41.5	90S
34	27.24	205	3.04	7200	2 8 .		
27	33.8	255	2.45	7200	3 2 .		
23	39.86	300	2.08	7010	3 6 .		
21	43.64	328	1.9	6813	4 5 .		
17	53.49	401	1.35	7193	5 0 .		
15	59.61	447	1.05	6584	5 6 .		
13	72.28	538	1.16	7200	M 0 6 3 2 6 3 . _ M _ _ _ _ . 7 5 C - -	42.5	90S
12	79.6	593	1.05	6400	7 1 .		
10	91.56	682	0.92	4888	8 0 .		
9.2	99.54	741	0.84	3882	1 0 0		
29	32.12	241	3.59	9420	M 0 7 2 2 3 2 . _ M _ _ _ _ . 7 5 C - -	48.5	90S
26	35.17	264	3.28	9420	3 6 .		
22	42.21	315	2.75	9183	4 5 .		
19	48.56	363	1.93	9043	5 0 .		
17	53.96	402	1.48	9208	5 6 .		
16	58.95	439	1.97	8355	M 0 7 3 2 5 6 . _ M _ _ _ _ . 7 5 C - -	53.5	90S
15	62.83	468	1.85	8042	6 3 .		
12	74.47	556	1.56	7121	7 1 .		
12	79.51	590	1.47	6721	8 0 .		
9.3	98.66	733	1.18	6637	1 0 0		
7.9	116.34	864	1	4794	1 1 2		
7.2	127.39	946	0.92	4794	1 2 5		
16	55.8	416	3.72	20000	M 0 8 2 2 5 6 . _ M _ _ _ _ . 7 5 C - -	81.5	90S
14	66.02	490	3.36	20000	M 0 8 3 2 6 3 . _ M _ _ _ _ . 7 5 C - -	81.5	90S
12	74.69	556	2.96	20000	7 1 .		
11	84.31	626	2.63	20000	8 0 .		
9	102.2	759	2.17	18367	1 0 0		
7.7	119.19	884	1.87	17935	1 1 2		
7	130.92	970	1.7	17575	1 2 5		
5.7	160.45	1195	1.38	17044	1 6 0		
5.3	175.21	1299	1.27	16406	1 8 0		
4.6	201.75	1491	1.11	15789	2 0 0		
4	228.91	1665	0.82	18916	M 0 8 4 2 2 2 5 _ M _ _ _ _ . 7 5 C - -	112.5	90S
7.9	116.55	870	3.28	29500	M 0 9 3 1 1 1 2 _ M _ _ _ _ . 7 5 C - -	131.5	90S
7.2	128.66	960	2.98	29500	1 2 5		
6.3	145.2	1079	2.29	29442	1 4 0		
5.7	160.29	1193	2.07	29330	1 6 0		
4	231.06	1696	1.56	25710	M 0 9 4 1 2 2 5 _ M _ _ _ _ . 7 5 C - -	156.5	90S
3.6	258.09	1892	1.51	24951	2 5 0		
3.1	300.18	2200	1.3	24951	2 8 0		
2.7	335.85	2457	1.16	24951	3 0 0		
2.6	357.95	2621	1.09	24951	3 6 0		
2.2	424.23	3103	0.92	24951	4 0 0		
2	471.32	3444	0.83	24951	4 5 0		
4.2	220.22	1608	2.74	41580	M 1 0 4 1 2 2 5 _ M _ _ _ _ . 7 5 C - -	217.5	90S
3.8	242.24	1768	2.49	41580	2 5 0		
3.3	278.36	2031	2.17	41580	2 8 0		
2.9	315.65	2300	1.92	41580	3 0 0		
2.6	348.16	2538	1.74	41580	3 6 0		
2.3	398.71	2904	1.52	41580	4 0 0		
2.1	443.06	3224	1.37	41580	4 5 0		
1.8	500.94	3642	1.21	41580	5 0 0		
1.6	580.78	4217	1.05	41580	6 5 0		
1.3	692.72	5022	0.88	41580	7 3 0		

NOTE
Other output speeds are available using 2 and 8 pole motors - Consult Application Engineering

SERIES M

SELECTION TABLES

GEARED MOTORS

0.75 kW

6 POLE

N2 R/MIN	i	M2 Nm	Fm	N	Unit Designation	Kg	Motor Size
Output Speed	Ratio	Output Torque	Service Factor	Overhung Load	Column Entry [1] Through [20] Spaces to be filled when entering order	Weight	
4.1	226.98	1653	3.84	64632	M 1 3 4 1 2 2 5 _ M _ _ _ _ . 7 5 C - -	292.5	90S
3.7	249.68	1818	3.49	64632	2 5 0		
3.2	286.9	2087	3.04	64632	2 8 0		
2.8	325.33	2363	2.69	64632	3 0 0		
2.6	358.84	2608	2.43	64632	3 6 0		
2.2	410.95	2985	2.13	64632	4 0 0		
2	463.22	3363	1.89	64632	4 5 0		
1.8	523.74	3799	1.67	64632	5 0 0		
1.5	607.22	4400	1.44	64632	6 5 0		
1.3	724.25	5239	1.21	64632	7 3 0		
1.1	858.69	6184	1.03	64632	8 6 0		
0.9	1024.19	7366	0.86	64632	1 0 C		
2.4	390.06	2836	3.74	80613	M 1 4 4 1 3 6 0 _ M _ _ _ _ . 7 5 C - -	408.5	90S
2.1	446.71	3245	3.26	80613	4 0 0		
1.9	492.49	3575	3.01	80613	4 5 0		
1.7	556.83	4038	2.67	80613	5 0 0		
1.4	645.58	4676	2.3	80613	6 5 0		
1.2	770.01	5568	1.93	80613	7 3 0		
1.1	801.52	5787	1.84	80613	8 6 0		
0.99	929.27	6702	1.59	80613	1 0 C		
0.83	1108.37	7982	1.33	80613	1 1 C		
0.76	1213.79	8732	1.22	80613	1 3 C		
0.61	1502.21	10781	0.94	80711	1 5 C		

1.1 kW

4 POLE

376	3.75	26	2.2	1543	M 0 1 2 2 3 . 6 _ M _ _ _ _ . 1 . 1 A - -	23.5	90S
278	5.07	36	1.85	1596	5 . 0		
245	5.76	41	1.72	1613	5 . 6		
216	6.53	47	1.59	1496	6 . 3		
169	8.35	60	1.32	1459	8 . 0		
157	9	65	1.24	1452	9 . 0		
124	11.36	82	1.03	1490	1 1 .		
109	12.88	92	0.94	1490	1 2 .		
96	14.71	106	0.85	1150	1 4 .		
393	3.59	25	3.88	3750	M 0 2 2 2 3 . 6 _ M _ _ _ _ . 1 . 1 A - -	26.5	90S
280	5.03	36	3.19	3950	5 . 0		
254	5.55	40	3.01	4000	5 . 6		
224	6.3	45	2.79	3992	6 . 3		
176	8	57	2.36	4000	8 . 0		
155	9.09	65	2.13	4000	9 . 0		
126	11.15	80	1.8	4000	1 1 .		
114	12.37	89	1.66	4000	1 2 .		
100	14.05	101	1.51	4000	1 4 .		
88	15.97	115	1.39	3913	1 6 .		
80	17.58	126	1.26	3767	1 8 .		
70	20.23	145	1.1	3534	2 0 .		
64	21.99	158	1.01	4000	2 2 .		
53	26.4	189	0.84	3740	2 8 .		
280	5.03	36	3.73	3920	M 0 3 2 2 5 . 0 _ M _ _ _ _ . 1 . 1 A - -	26.5	90S
254	5.55	39	3.51	3970	5 . 6		
224	6.3	45	3.24	3990	6 . 3		
176	8	57	2.78	4000	8 . 0		
155	9.09	65	2.55	4000	9 . 0		
126	11.15	80	2.23	4000	1 1 .		
114	12.37	89	2.09	4000	1 2 .		
100	14.05	101	1.91	4000	1 4 .		
88	15.97	114	1.79	3931	1 6 .		
80	17.58	126	1.64	3836	1 8 .		
70	20.23	145	1.43	3498	2 0 .		
64	21.99	158	1.32	3303	2 2 .		
53	26.4	189	1.11	2459	2 8 .		
45	31.68	227	0.92	2680	3 2 .		
40	35.69	255	0.82	1870	3 6 .		
112	12.54	90	3.13	5720	M 0 4 2 2 1 2 . _ M _ _ _ _ . 1 . 1 A - -	35.5	90S
97	14.58	105	2.8	5940	1 4 .		
86	16.31	117	2.6	6130	1 6 .		
81	17.39	125	2.48	6229	1 8 .		
68	20.61	148	2.15	6512	2 0 .		
64	22	158	2.03	6624	2 2 .		
52	27.3	196	1.71	6794	2 8 .		
44	32.19	231	1.46	6991	3 2 .		
40	35.25	253	1.33	7055	3 6 .		
33	43.2	310	1.09	6568	4 5 .		
29	48.15	344	0.98	7140	5 0 .		
24	58.38	414	0.82	6400	M 0 4 3 2 5 6 . _ M _ _ _ _ . 1 . 1 A - -	36.5	90S

NOTE

Other output speeds are available using 2 and 8 pole motors - Consult Application Engineering

SERIES M

SELECTION TABLES

GEARED MOTORS

1.1 kW

4 POLE

N2 R/MIN	i	M2 Nm	Fm	N	Unit Designation	Kg	Motor Size
Output Speed	Ratio	Output Torque	Service Factor	Overhung Load	Column Entry <input type="text" value="1"/> Through <input type="text" value="20"/> Spaces to be filled when entering order	Weight	
86	16.31	117	3.82	5743	M 0 5 2 2 1 6 . _ M _ _ _ _ 1 . 1 A - -	36.5	90S
81	17.39	125	3.58	5832	1 8 .		
68	20.61	148	3.02	6042	2 0 .		
64	22	159	2.83	5957	2 2 .		
52	27.3	197	2.28	6188	2 8 .		
44	32.19	232	1.94	6307	3 2 .		
40	35.25	253	1.78	6015	3 6 .		
33	43.2	310	1.14	6279	4 5 .		
29	48.15	345	1.05	5712	5 0 .		
24	58.38	417	1.08	5860	M 0 5 3 2 5 6 . _ M _ _ _ _ 1 . 1 A - -	37.5	90S
22	64.29	458	0.98	4980	6 3 .		
19	73.95	526	0.85	3570	7 1 .		
55	25.51	184	3.39	7200	M 0 6 2 2 2 2 . _ M _ _ _ _ 1 . 1 A - -	41.5	90S
52	27.24	196	3.18	7200	2 8 .		
42	33.8	244	2.56	7200	3 2 .		
35	39.86	286	2.18	7200	3 6 .		
32	43.64	314	1.99	7200	4 5 .		
26	53.49	383	1.37	7200	5 0 .		
24	59.61	428	1.1	7200	5 6 .		
20	72.28	513	1.22	7200	M 0 6 3 2 6 3 . _ M _ _ _ _ 1 . 1 A - -	42.5	90S
18	79.6	568	1.1	7200	7 1 .		
15	91.56	649	0.96	7200	8 0 .		
14	99.54	708	0.88	7200	1 0 0		
44	32.12	231	3.63	9517	M 0 7 2 2 3 2 . _ M _ _ _ _ 1 . 1 A - -	48.5	90S
40	35.17	252	3.35	9379	3 6 .		
33	42.21	302	2.86	9338	4 5 .		
29	48.56	347	2.02	9397	5 0 .		
26	53.96	385	1.55	10000	5 6 .		
24	58.95	420	1.79	8510	M 0 7 3 2 5 6 . _ M _ _ _ _ 1 . 1 A - -	53.5	90S
22	62.83	446	1.72	8210	6 3 .		
19	74.47	529	1.54	8500	7 1 .		
18	79.51	564	1.48	8043	8 0 .		
14	98.66	701	1.24	6317	1 0 0		
12	116.34	825	1.05	5740	1 1 2		
11	127.39	900	0.96	4490	1 2 5		
25	55.8	399	3.85	20000	M 0 8 2 2 5 6 . _ M _ _ _ _ 1 . 1 A - -	81.5	90S
23	60.33	427	3.74	20000	M 0 8 3 2 5 6 . _ M _ _ _ _ 1 . 1 A - -	81.5	90S
21	66.02	470	3.51	20000	6 3 .		
19	74.69	530	3.11	20000	7 1 .		
17	84.31	598	2.76	20000	8 0 .		
14	102.2	726	2.27	18631	1 0 0		
12	119.19	844	1.95	18177	1 1 2		
11	130.92	928	1.78	17391	1 2 5		
8.8	160.45	1138	1.45	18378	1 6 0		
8	175.21	1244	1.33	17221	1 8 0		
7	201.75	1424	1.16	15194	2 0 0		
6.2	228.91	1588	0.86	18916	M 0 8 4 2 2 2 5 _ M _ _ _ _ 1 . 1 A - -	112.5	90S
5.4	258.98	1795	0.82	17870	2 5 0		
15	93.92	669	3.94	29600	M 0 9 3 1 9 0 . _ M _ _ _ _ 1 . 1 A - -	131.5	90S
14	103.68	739	3.57	29600	1 0 0		
12	116.55	831	3.44	29500	1 1 2		
11	128.66	919	3.11	29500	1 2 5		
10	145.2	1031	2.4	29413	1 4 0		
8.8	160.29	1135	2.17	29397	1 6 0		
6.1	231.06	1621	1.63	25710	M 0 9 4 1 2 2 5 _ M _ _ _ _ 1 . 1 A - -	156.5	90S
5.5	258.09	1808	1.58	24951	2 5 0		
4.7	300.18	2103	1.36	24951	2 8 0		
4.2	335.85	2349	1.22	24951	3 0 0		
3.9	357.95	2506	1.14	24951	3 6 0		
3.3	424.23	2968	0.96	24951	4 0 0		
3	471.32	3293	0.87	24951	4 5 0		
2.8	503.22	3514	0.81	24951	5 0 0		
9	156.57	1109	3.76	49600	M 1 0 3 1 1 6 0 _ M _ _ _ _ 1 . 1 A - -	179.5	90S
6.4	220.22	1536	2.87	41580	M 1 0 4 1 2 2 5 _ M _ _ _ _ 1 . 1 A - -	217.5	90S
5.8	242.24	1689	2.61	41580	2 5 0		
5.1	278.36	1940	2.27	41580	2 8 0		
4.5	315.65	2198	2.01	41580	3 0 0		
4	348.16	2426	1.82	41580	3 6 0		
3.5	398.71	2776	1.59	41580	4 0 0		
3.2	443.06	3081	1.43	41580	4 5 0		
2.8	500.94	3481	1.27	41580	5 0 0		
2.4	580.78	4033	1.09	41580	6 5 0		
2	692.72	4804	0.92	41580	7 3 0		

NOTE

Other output speeds are available using 2 and 8 pole motors - Consult Application Engineering

SERIES M

SELECTION TABLES

GEARED MOTORS

1.1 kW

4 POLE

N2 R/MIN	i	M2 Nm	Fm	N	Unit Designation	Kg	Motor Size
Output Speed	Ratio	Output Torque	Service Factor	Overhung Load	Column Entry [1] Through [20] Spaces to be filled when entering order	Weight	
5.6	249.68	1737	3.65	64632	M 1 3 4 1 2 5 0 _ M _ _ _ _ 1 . 1 A - -	292.5	90S
4.9	286.9	1995	3.18	64632	2 8 0		
4.3	325.33	2260	2.81	64632	3 0 0		
3.9	358.84	2494	2.55	64632	3 6 0		
3.4	410.95	2854	2.22	64632	4 0 0		
3	463.22	3216	1.97	64632	4 5 0		
2.7	523.74	3633	1.75	64632	5 0 0		
2.3	607.22	4209	1.51	64632	6 5 0		
1.9	724.25	5013	1.27	64632	7 3 0		
1.6	858.69	5911	1.07	64632	8 6 0		
1.4	1024.19	7043	0.9	64632	1 0 C		
1.2	1140.7	7829	0.81	64632	1 1 C		
3.6	390.06	2713	3.91	80613	M 1 4 4 1 3 6 0 _ M _ _ _ _ 1 . 1 A - -	408.5	90S
3.2	446.71	3105	3.41	80613	4 0 0		
2.9	492.49	3420	3.15	80613	4 5 0		
2.5	556.83	3864	2.79	80613	5 0 0		
2.2	645.58	4475	2.41	80613	6 5 0		
1.8	770.01	5330	2.02	80613	7 3 0		
1.8	801.52	5534	1.93	80613	8 6 0		
1.5	929.27	6410	1.66	80613	1 0 C		
1.3	1108.37	7636	1.4	80613	1 1 C		
1.2	1213.79	8356	1.28	80613	1 3 C		
0.94	1502.21	10314	0.98	80711	1 5 C		
0.78	1802.65	12351	0.82	80711	1 8 C		

1.1 kW

6 POLE

247	3.75	41	1.66	1500	M 0 1 2 2 3 . 6 _ M _ _ _ _ 1 . 1 C - -	24.5	90L
183	5.07	55	1.36	1490	5 . 0		
161	5.76	63	1.24	1480	5 . 6		
142	6.53	72	1.11	1490	6 . 3		
111	8.35	91	0.93	1490	8 . 0		
103	9	98	0.88	1380	9 . 0		
258	3.59	39	2.92	4000	M 0 2 2 2 3 . 6 _ M _ _ _ _ 1 . 1 C - -	27.5	90L
184	5.03	55	2.37	4000	5 . 0		
167	5.55	61	2.19	4000	5 . 6		
147	6.3	69	1.99	4000	6 . 3		
116	8	88	1.65	4000	8 . 0		
102	9.09	100	1.5	4000	9 . 0		
83	11.15	123	1.28	4000	1 1 .		
75	12.37	136	1.17	4000	1 2 .		
66	14.05	154	1.03	4000	1 4 .		
58	15.97	175	0.91	4000	1 6 .		
53	17.58	193	0.83	3680	1 8 .		
258	3.59	39	3.4	4000	M 0 3 2 2 3 . 6 _ M _ _ _ _ 1 . 1 C - -	27.5	90L
184	5.03	55	2.77	4000	5 . 0		
167	5.55	61	2.6	4000	5 . 6		
147	6.3	69	2.4	4000	6 . 3		
116	8	88	2.07	4000	8 . 0		
102	9.09	99	1.9	4000	9 . 0		
83	11.15	122	1.66	4000	1 1 .		
75	12.37	136	1.53	4000	1 2 .		
66	14.05	154	1.35	4000	1 4 .		
58	15.97	175	1.19	4000	1 6 .		
53	17.58	193	1.08	3680	1 8 .		
46	20.23	222	0.94	2880	2 0 .		
42	21.99	241	0.87	2340	2 2 .		
74	12.54	137	2.36	6370	M 0 4 2 2 1 2 . _ M _ _ _ _ 1 . 1 C - -	36.5	90L
63	14.58	160	2.1	6624	1 4 .		
57	16.31	179	1.88	6815	1 6 .		
53	17.39	191	1.76	6790	1 8 .		
45	20.61	226	1.49	6640	2 0 .		
42	22	242	1.39	6416	2 2 .		
34	27.3	299	1.13	5253	2 8 .		
29	32.19	354	0.95	5720	3 2 .		
26	35.25	386	0.87	5074	3 6 .		
74	12.54	138	3.08	5876	M 0 5 2 2 1 2 . _ M _ _ _ _ 1 . 1 C - -	37.5	90L
63	14.58	161	2.79	6072	1 4 .		
57	16.31	179	2.51	6216	1 6 .		
53	17.39	191	2.35	6477	1 8 .		
45	20.61	227	1.98	6346	2 0 .		
42	22	242	1.86	6103	2 2 .		
34	27.3	300	1.5	5173	2 8 .		
29	32.19	354	1.27	4327	3 2 .		
26	35.25	386	1.17	4327	3 6 .		
21	43.2	473	0.86	3343	4 5 .		
51	18.05	199	3	7200	M 0 6 2 2 1 6 . _ M _ _ _ _ 1 . 1 C - -	42.5	90L
46	20.2	222	2.81	7200	1 8 .		
43	21.53	237	2.64	7200	2 0 .		
36	25.51	281	2.22	7200	2 2 .		
34	27.24	300	2.08	7200	2 8 .		
27	33.8	372	1.68	7200	3 2 .		
23	39.86	438	1.43	6680	3 6 .		
21	43.64	479	1.31	6136	4 5 .		
17	53.49	585	0.93	7182	5 0 .		

NOTE

Other output speeds are available using 2 and 8 pole motors - Consult Application Engineering

SERIES M

SELECTION TABLES

GEARED MOTORS

1.1 kW

6 POLE

N2 R/MIN	i	M2 Nm	Fm	N	Unit Designation	Kg	Motor Size
Output Speed	Ratio	Output Torque	Service Factor	Overhung Load	Column Entry 1 Through 20 Spaces to be filled when entering order	Weight	
45	20.54	225	3.71	8987	M 0 7 2 2 2 0 . _ M _ _ _ _ 1 . 1 C - -	49.5	90L
40	23.23	255	3.32	8888	2 2 .		
34	26.93	295	2.91	8888	2 8 .		
29	32.12	352	2.46	8405	3 2 .		
26	35.17	385	2.25	8405	3 6 .		
22	42.21	460	1.88	7755	4 5 .		
19	48.56	529	1.32	7370	5 0 .		
17	53.96	586	1.02	7823	5 6 .		
16	58.95	641	1.35	6840	M 0 7 3 2 5 6 . _ M _ _ _ _ 1 . 1 C - -	54.5	90L
15	62.83	683	1.27	6240	6 3 .		
12	74.47	812	1.07	4470	7 1 .		
12	79.51	861	1.01	3701	8 0 .		
9.4	98.66	1070	0.81	3539	1 0 0		
21	44.38	486	3.39	20000	M 0 8 2 2 4 5 . _ M _ _ _ _ 1 . 1 C - -	82.5	90L
19	48.46	530	3.11	20000	5 0 .		
17	55.8	608	2.55	18720	5 6 .		
15	60.33	654	2.52	20000	M 0 8 3 2 5 6 . _ M _ _ _ _ 1 . 1 C - -	82.5	90L
14	66.02	716	2.3	18126	6 3 .		
12	74.69	811	2.03	17846	7 1 .		
11	84.31	914	1.8	17539	8 0 .		
9.1	102.2	1108	1.49	15510	1 0 0		
7.8	119.19	1290	1.28	14323	1 1 2		
7.1	130.92	1416	1.17	13333	1 2 5		
5.8	160.45	1744	0.95	11871	1 6 0		
5.3	175.21	1895	0.87	10117	1 8 0		
15	61.13	669	3.69	29600	M 0 9 2 1 6 3 . _ M _ _ _ _ 1 . 1 C - -	123.5	90L
13	68.74	751	3.23	29600	7 1 .		
11	82.51	899	3.18	29500	M 0 9 3 1 8 0 . _ M _ _ _ _ 1 . 1 C - -	132.5	90L
10	93.92	1021	2.58	29400	9 0 .		
8.9	103.68	1128	2.34	29300	1 0 0		
7.9	116.55	1270	2.25	29282	1 1 2		
7.2	128.66	1401	2.04	29258	1 2 5		
6.4	145.2	1575	1.57	29166	1 4 0		
5.8	160.29	1740	1.42	29033	1 6 0		
4	231.06	2475	1.07	25710	M 0 9 4 1 2 2 5 _ M _ _ _ _ 1 . 1 C - -	157.5	90L
3.6	258.09	2761	1.03	24951	2 5 0		
3.1	300.18	3209	0.89	24951	2 8 0		
7.1	129.94	1410	3.13	49100	M 1 0 3 1 1 2 5 _ M _ _ _ _ 1 . 1 C - -	180.5	90L
6.8	135.88	1473	2.83	49100	1 4 0		
5.9	156.57	1694	2.46	48700	1 6 0		
4.2	220.22	2346	1.88	41580	M 1 0 4 1 2 2 5 _ M _ _ _ _ 1 . 1 C - -	218.5	90L
3.8	242.24	2580	1.71	41580	2 5 0		
3.3	278.36	2963	1.49	41580	2 8 0		
2.9	315.65	3355	1.32	41580	3 0 0		
2.7	348.16	3702	1.19	41580	3 6 0		
2.3	398.71	4237	1.04	41580	4 0 0		
2.1	443.06	4703	0.94	41580	4 5 0		
1.8	500.94	5312	0.83	41580	5 0 0		
4.1	226.98	2411	2.63	64632	M 1 3 4 1 2 2 5 _ M _ _ _ _ 1 . 1 C - -	293.5	90L
3.7	249.68	2652	2.39	64632	2 5 0		
3.2	286.9	3045	2.08	64632	2 8 0		
2.8	325.33	3448	1.84	64632	3 0 0		
2.6	358.84	3805	1.67	64632	3 6 0		
2.3	410.95	4354	1.46	64632	4 0 0		
2	463.22	4906	1.29	64632	4 5 0		
1.8	523.74	5542	1.15	64632	5 0 0		
1.5	607.22	6418	0.99	64632	6 5 0		
1.3	724.25	7643	0.83	64632	7 3 0		
3.4	271.4	2884	3.67	80613	M 1 4 4 1 2 5 0 _ M _ _ _ _ 1 . 1 C - -	409.5	90L
3	311.86	3311	3.2	80613	2 8 0		
2.6	353.64	3749	2.83	80613	3 0 0		
2.4	390.06	4137	2.56	80613	3 6 0		
2.1	446.71	4734	2.24	80613	4 0 0		
1.9	492.49	5215	2.07	80613	4 5 0		
1.7	556.83	5891	1.83	80613	5 0 0		
1.4	645.58	6822	1.58	80613	6 5 0		
1.2	770.01	8123	1.33	80613	7 3 0		
1.2	801.52	8442	1.26	80613	8 6 0		
0	929.27	9777	1.09	80613	1 0 C		
0.83	1108.37	11643	0.92	80613	1 1 C		
0.76	1213.79	12739	0.84	80613	1 3 C		

NOTE

Other output speeds are available using 2 and 8 pole motors - Consult Application Engineering

SERIES M

SELECTION TABLES

GEARED MOTORS

1.5 kW

4 POLE

N2 R/MIN	i	M2 Nm	Fm	N	Unit Designation	Kg	Motor Size
Output Speed	Ratio	Output Torque	Service Factor	Overhung Load	Column Entry [1] Through [20] Spaces to be filled when entering order	Weight	
379	3.75	36	1.63	1484	M 0 1 2 2 3 . 6 _ M _ _ _ _ 1 . 5 A - -	24.5	90L
280	5.07	49	1.36	1517	5 . 0		
246	5.76	56	1.27	1521	5 . 6		
218	6.53	63	1.18	1340	6 . 3		
170	8.35	81	0.97	1280	8 . 0		
158	9	88	0.91	1270	9 . 0		
396	3.59	34	2.87	3728	M 0 2 2 2 3 . 6 _ M _ _ _ _ 1 . 5 A - -	27.5	90L
282	5.03	49	2.36	3917	5 . 0		
256	5.55	54	2.23	3967	5 . 6		
225	6.3	61	2.06	3984	6 . 3		
178	8	78	1.74	4000	8 . 0		
156	9.09	88	1.57	4000	9 . 0		
127	11.15	108	1.33	4000	1 1 .		
115	12.37	120	1.23	4000	1 2 .		
101	14.05	137	1.12	4000	1 4 .		
89	15.97	156	1.03	3850	1 6 .		
81	17.58	171	0.93	3640	1 8 .		
70	20.23	197	0.81	3280	2 0 .		
396	3.59	34	3.38	3690	M 0 3 2 2 3 . 6 _ M _ _ _ _ 1 . 5 A - -	27.5	90L
282	5.03	48	2.76	3898	5 . 0		
256	5.55	54	2.59	3948	5 . 6		
225	6.3	61	2.4	3982	6 . 3		
178	8	78	2.06	4000	8 . 0		
156	9.09	89	1.89	4000	9 . 0		
127	11.15	108	1.65	4000	1 1 .		
115	12.37	120	1.54	4000	1 2 .		
101	14.05	137	1.41	4000	1 4 .		
89	15.97	155	1.32	3901	1 6 .		
81	17.58	171	1.21	3764	1 8 .		
70	20.23	197	1.06	3280	2 0 .		
65	21.99	214	0.97	3000	2 2 .		
54	26.4	256	0.82	1789	2 8 .		
113	12.54	122	2.31	5611	M 0 4 2 2 1 2 . _ M _ _ _ _ 1 . 5 A - -	36.5	90L
97	14.58	142	2.07	5814	1 4 .		
87	16.31	159	1.92	5915	1 6 .		
82	17.39	170	1.83	6000	1 8 .		
69	20.61	201	1.59	6240	2 0 .		
65	22	215	1.5	6333	2 2 .		
52	27.3	265	1.26	6499	2 8 .		
44	32.19	313	1.08	6840	3 2 .		
40	35.25	342	0.99	6950	3 6 .		
33	43.2	420	0.8	6110	4 5 .		
113	12.54	122	3.47	5158	M 0 5 2 2 1 2 . _ M _ _ _ _ 1 . 5 A - -	37.5	90L
97	14.58	143	3.15	5238	1 4 .		
87	16.31	159	2.82	5630	1 6 .		
82	17.39	170	2.64	5710	1 8 .		
69	20.61	201	2.23	5869	2 0 .		
65	22	215	2.09	5651	2 2 .		
52	27.3	267	1.68	5575	2 8 .		
44	32.19	314	1.43	5658	3 2 .		
40	35.25	342	1.31	5153	3 6 .		
33	43.2	420	0.84	5610	4 5 .		
79	18.05	176	3.37	7200	M 0 6 2 2 1 6 . _ M _ _ _ _ 1 . 5 A - -	42.5	90L
70	20.2	197	3.17	7200	1 8 .		
66	21.53	210	2.97	7200	2 0 .		
56	25.51	249	2.51	7200	2 2 .		
52	27.24	266	2.35	7200	2 8 .		
42	33.8	330	1.89	7200	3 2 .		
36	39.86	388	1.61	7200	3 6 .		
33	43.64	426	1.47	7200	4 5 .		
27	53.49	519	1.01	7200	5 0 .		
24	59.61	580	0.81	7200	5 6 .		
20	72.28	694	0.9	7200	M 0 6 3 2 6 3 . _ M _ _ _ _ 1 . 5 A - -	43.5	90L

NOTE

Other output speeds are available using 2 and 8 pole motors - Consult Application Engineering

SERIES M

SELECTION TABLES

GEARED MOTORS

1.5 kW

4 POLE

N2 R/MIN	i	M2 Nm	Fm	N	Unit Designation	Kg	Motor Size
Output Speed	Ratio	Output Torque	Service Factor	Overhung Load	Column Entry 1 Through 20 Spaces to be filled when entering order	Weight	
61	23.23	226	3.59	9013	M 0 7 2 2 2 2 . _ M _ _ _ _ _ 1 . 5 A - -	49.5	90L
53	26.93	262	3.14	8800	2 8 .		
44	32.12	313	2.68	8966	3 2 .		
40	35.17	342	2.47	8670	3 6 .		
34	42.21	409	2.11	8583	4 5 .		
29	48.56	470	1.49	8708	5 0 .		
26	53.96	521	1.14	10000	5 6 .		
24	58.95	568	1.33	7426	M 0 7 3 2 5 6 . _ M _ _ _ _ _ 1 . 5 A - -	54.5	90L
23	62.83	604	1.27	6908	6 3 .		
19	74.47	717	1.14	7410	7 1 .		
18	79.51	764	1.09	6620	8 0 .		
14	98.66	949	0.91	3640	1 0 0		
32	44.38	432	3.82	20000	M 0 8 2 2 4 5 . _ M _ _ _ _ _ 1 . 5 A - -	82.5	90L
29	48.46	471	3.5	20000	5 0 .		
25	55.8	541	2.85	19737	5 6 .		
24	60.33	579	2.76	19600	M 0 8 3 2 5 6 . _ M _ _ _ _ _ 1 . 5 A - -	82.5	90L
22	66.02	636	2.59	19310	6 3 .		
19	74.69	717	2.3	18882	7 1 .		
17	84.31	810	2.04	19178	8 0 .		
14	102.2	983	1.68	17066	1 0 0		
12	119.19	1143	1.44	16851	1 1 2		
11	130.92	1257	1.31	15494	1 2 5		
8.9	160.45	1541	1.07	17200	1 6 0		
8.1	175.21	1684	0.98	15200	1 8 0		
7	201.75	1929	0.86	11700	2 0 0		
26	55.18	536	3.75	29700	M 0 9 2 1 5 6 . _ M _ _ _ _ _ 1 . 5 A - -	123.5	90L
21	68.74	668	3.7	29600	7 1 .		
17	82.51	797	3.58	29600	M 0 9 3 1 8 0 . _ M _ _ _ _ _ 1 . 5 A - -	132.5	90L
15	93.92	906	2.91	29462	9 0 .		
14	103.68	1000	2.64	29434	1 0 0		
12	116.55	1126	2.54	29348	1 1 2		
11	128.66	1244	2.3	29320	1 2 5		
10	145.2	1396	1.77	29200	1 4 0		
8.9	160.29	1537	1.61	29166	1 6 0		
6.1	231.06	2195	1.2	25710	M 0 9 4 1 2 2 5 _ M _ _ _ _ _ 1 . 5 A - -	157.5	90L
5.5	258.09	2449	1.17	24951	2 5 0		
4.7	300.18	2847	1	24951	2 8 0		
4.2	335.85	3181	0.9	24951	3 0 0		
4	357.95	3393	0.84	24951	3 6 0		
13	109.97	1059	3.56	49600	M 1 0 3 1 1 0 0 _ M _ _ _ _ _ 1 . 5 A - -	180.5	90L
11	129.94	1250	3.53	49300	1 2 5		
10	135.88	1303	3.19	49300	1 4 0		
9.1	156.57	1502	2.77	48965	1 6 0		
6.4	220.22	2080	2.12	41580	M 1 0 4 1 2 2 5 _ M _ _ _ _ _ 1 . 5 A - -	218.5	90L
5.9	242.24	2287	1.93	41580	2 5 0		
5.1	278.36	2628	1.68	41580	2 8 0		
4.5	315.65	2976	1.48	41580	3 0 0		
4.1	348.16	3284	1.34	41580	3 6 0		
3.6	398.71	3760	1.17	41580	4 0 0		
3.2	443.06	4172	1.06	41580	4 5 0		
2.8	500.94	4714	0.94	41580	5 0 0		
2.4	580.78	5461	0.81	41580	6 5 0		
6.3	226.98	2139	2.97	64632	M 1 3 4 1 2 2 5 _ M _ _ _ _ _ 1 . 5 A - -	293.5	90L
5.7	249.68	2352	2.7	64632	2 5 0		
4.9	286.9	2702	2.35	64632	2 8 0		
4.4	325.33	3060	2.07	64632	3 0 0		
4	358.84	3377	1.88	64632	3 6 0		
3.5	410.95	3865	1.64	64632	4 0 0		
3.1	463.22	4355	1.46	64632	4 5 0		
2.7	523.74	4920	1.29	64632	5 0 0		
2.3	607.22	5699	1.11	64632	6 5 0		
2	724.25	6788	0.94	64632	7 3 0		
4.6	311.86	2940	3.6	80613	M 1 4 4 1 2 8 0 _ M _ _ _ _ _ 1 . 5 A - -	409.5	90L
4	353.64	3329	3.18	80613	3 0 0		
3.6	390.06	3673	2.88	80613	3 6 0		
3.2	446.71	4204	2.52	80613	4 0 0		
2.9	492.49	4631	2.33	80613	4 5 0		
2.6	556.83	5232	2.06	80613	5 0 0		
2.2	645.58	6059	1.78	80613	6 5 0		
1.8	770.01	7217	1.49	80613	7 3 0		
1.8	801.52	7494	1.42	80613	8 6 0		
1.5	929.27	8680	1.23	80613	1 0 C		
1.3	1108.37	10340	1.03	80613	1 1 C		
1.2	1213.79	11314	0.94	80613	1 3 C		

NOTE

Other output speeds are available using 2 and 8 pole motors - Consult Application Engineering

SERIES M

SELECTION TABLES

GEARED MOTORS

1.5 kW

6 POLE

N2 R/MIN	i	M2 Nm	Fm	N	Unit Designation	Kg	Motor Size
Output Speed	Ratio	Output Torque	Service Factor	Overhung Load	Column Entry [1] Through [20] Spaces to be filled when entering order	Weight	
251	3.75	56	1.21	980	M 0 1 2 2 3 . 6 _ M _ _ _ _ 1 . 5 C - -	36	100L
186	5.07	76	1.00	980	5 . 0		
163	5.76	86	0.91	980	5 . 6		
144	6.53	97	0.82	980	6 . 3		
262	3.59	54	2.15	3100	M 0 2 2 2 3 . 6 _ M _ _ _ _ 1 . 5 C - -	39	100L
187	5.03	75	1.74	3100	5 . 0		
169	5.55	83	1.62	3100	5 . 6		
149	6.30	94	1.47	3100	6 . 3		
118	8.00	119	1.21	3100	8 . 0		
103	9.09	136	1.11	3100	9 . 0		
84	11.15	167	0.95	2600	1 1 .		
76	12.37	185	0.87	2300	1 2 .		
262	3.59	54	2.50	2300	M 0 3 2 2 3 . 6 _ M _ _ _ _ 1 . 5 C - -	39	100L
187	5.03	75	2.04	2300	5 . 0		
169	5.55	83	1.92	2300	5 . 6		
149	6.30	94	1.78	2300	6 . 3		
118	8.00	119	1.52	2300	8 . 0		
103	9.09	136	1.40	2300	9 . 0		
84	11.15	167	1.22	2300	1 1 .		
76	12.37	185	1.13	2300	1 2 .		
67	14.05	210	1.00	2300	1 4 .		
59	15.97	238	0.88	2050	1 6 .		
53	17.58	263	0.80	1900	1 8 .		
184	5.04	75	3.59	5180	M 0 4 2 2 5 . 0 _ M _ _ _ _ 1 . 5 C - -	49	100L
164	5.65	85	3.36	5270	5 . 6		
146	6.34	95	3.08	5360	6 . 3		
115	8.05	120	2.56	5530	8 . 0		
101	9.13	137	2.32	5670	9 . 0		
85	10.89	163	2.04	5920	1 1 .		
74	12.54	188	1.73	6119	1 2 .		
63	14.58	219	1.54	6331	1 4 .		
57	16.31	244	1.38	6489	1 6 .		
53	17.39	261	1.29	6491	1 8 .		
45	20.61	309	1.09	6232	2 0 .		
42	22	330	1.02	5846	2 2 .		
34	27.3	407	0.83	4186	2 8 .		
115	8.05	121	3.71	5060	M 0 5 2 2 8 . 0 _ M _ _ _ _ 1 . 5 C - -	49	100L
101	9.13	137	3.27	5460	9 . 0		
85	10.89	164	2.74	5700	1 1 .		
74	12.54	188	2.26	5732	1 2 .		
63	14.58	219	2.05	5904	1 4 .		
57	16.31	244	1.84	6028	1 6 .		
53	17.39	261	1.72	6212	1 8 .		
45	20.61	309	1.45	5878	2 0 .		
42	22	330	1.36	5501	2 2 .		
34	27.3	409	1.1	4063	2 8 .		
29	32.19	483	0.93	2754	3 2 .		
26	35.25	526	0.85	2754	3 6 .		
69	13.48	203	3.08	7200	M 0 6 2 2 1 2 . _ M _ _ _ _ 1 . 5 C - -	54	100L
60	15.52	233	2.26	7200	1 4 .		
51	18.05	271	2.2	7200	1 6 .		
46	20.2	303	2.06	7200	1 8 .		
43	21.53	323	1.93	7200	2 0 .		
36	25.51	383	1.63	7200	2 2 .		
34	27.24	409	1.53	7200	2 8 .		
27	33.8	507	1.23	7200	3 2 .		
23	39.86	597	1.05	6301	3 6 .		
21	43.64	654	0.96	5363	4 5 .		
64	14.34	215	3.75	8921	M 0 7 2 2 1 4 . _ M _ _ _ _ 1 . 5 C - -	62	100L
57	16.26	243	3.35	8727	1 6 .		
52	17.94	269	3.06	8543	1 8 .		
45	20.54	308	2.72	8251	2 0 .		
40	23.23	347	2.43	8080	2 2 .		
34	26.93	403	2.13	8080	2 8 .		
29	32.12	480	1.81	7246	3 2 .		
26	35.17	525	1.65	7246	3 6 .		
22	42.21	628	1.38	6122	4 5 .		
19	48.56	722	0.97	5457	5 0 .		
16	58.95	874	0.99	5110	M 0 7 3 2 5 6 . _ M _ _ _ _ 1 . 5 C - -	66	100L
15	62.83	931	0.93	4180	6 3 .		
28	32.97	493	3.35	20000	M 0 8 2 2 3 2 . _ M _ _ _ _ 1 . 5 C - -	94	100L
26	36.21	541	3.04	20000	3 6 .		
21	44.38	663	2.49	18642	4 5 .		
19	48.46	723	2.28	18360	5 0 .		
17	55.8	829	1.87	17258	5 6 .		

NOTE
Other output speeds are available using 2 and 8 pole motors - Consult Application Engineering

SERIES M

SELECTION TABLES

GEARED MOTORS

1.5 kW

6 POLE

N2 R/MIN	i	M2 Nm	Fm	N	Unit Designation	Kg	Motor Size
Output Speed	Ratio	Output Torque	Service Factor	Overhung Load	Column Entry <input type="text" value="1"/> Through <input type="text" value="20"/> Spaces to be filled when entering order	Weight	
15	60.33	891	1.85	18038	M 0 8 3 2 5 6 . . M _ _ _ _ _ 1 . 5 C - -	95	100L
14	66.02	976	1.69	15984	6 3 . .		
12	74.69	1107	1.49	15384	7 1 . .		
11	84.31	1246	1.32	14726	8 0 . .		
9.1	102.2	1510	1.09	12244	1 0 0		
7.8	119.19	1759	0.94	10194	1 1 2		
7.1	130.92	1931	0.85	8484	1 2 5		
17	55.18	822	2.37	29600	M 0 9 2 1 5 6 . . M _ _ _ _ _ 1 . 5 C - -	135	100L
15	61.13	913	2.7	29472	6 3 . .		
13	68.74	1025	2.37	29372	7 1 . .		
15	59.85	889	2.97	29500	M 0 9 3 1 5 6 . . M _ _ _ _ _ 1 . 5 C - -	144	100L
14	66.49	987	2.67	29400	6 3 . .		
12	74.26	1104	2.59	29400	7 1 . .		
11	82.51	1226	2.33	29318	8 0 . .		
10	93.92	1393	1.89	29181	9 0 . .		
8.9	103.68	1539	1.72	29081	1 0 0		
7.9	116.55	1732	1.65	29034	1 1 2		
7.2	128.66	1910	1.5	28982	1 2 5		
6.4	145.2	2148	1.15	28851	1 4 0		
5.8	160.29	2373	1.04	28693	1 6 0		
10	95.44	1414	2.67	49000	M 1 0 3 1 9 0 . . M _ _ _ _ _ 1 . 5 C - -	193	100L
8.4	109.97	1630	2.31	48700	1 0 0		
8.2	112.77	1670	2.64	48700	1 1 2		
7.1	129.94	1923	2.29	48200	1 2 5		
6.8	135.88	2009	2.07	48136	1 4 0		
5.9	156.57	2310	1.81	47734	1 6 0		
4.2	220.22	3199	1.38	41580	M 1 0 4 1 2 2 5 _ M _ _ _ _ _ 1 . 5 C - -	230	100L
3.8	242.24	3518	1.25	41580	2 5 0		
3.3	278.36	4040	1.09	41580	2 8 0		
2.9	315.65	4575	0.96	41580	3 0 0		
2.7	348.16	5049	0.87	41580	3 6 0		
7.3	126.62	1858	3.42	66800	M 1 3 3 1 1 2 5 _ M _ _ _ _ _ 1 . 5 C - -	263	100L
6.7	139.07	2035	3.17	66700	1 4 0		
6	154.89	2265	2.85	66700	1 6 0		
5.3	173.37	2547	2.49	66600	1 8 0		
5	184.46	2715	2.34	66500	2 0 0		
4.4	212.09	3113	2.07	66400	2 2 5		
4.1	226.98	3288	1.93	64632	M 1 3 4 1 2 2 5 _ M _ _ _ _ _ 1 . 5 C - -	305	100L
3.7	249.68	3616	1.76	64632	2 5 0		
3.2	286.9	4153	1.53	64632	2 8 0		
2.8	325.33	4702	1.35	64632	3 0 0		
2.6	358.84	5188	1.22	64632	3 6 0		
2.3	410.95	5937	1.07	64632	4 0 0		
2	463.22	6691	0.95	64632	4 5 0		
1.8	523.74	7558	0.84	64632	5 0 0		
4.4	211.96	3101	3.26	80900	M 1 4 3 1 2 2 5 _ M _ _ _ _ _ 1 . 5 C - -	392	100L
3.7	246.73	3576	2.96	80613	M 1 4 4 1 2 2 5 _ M _ _ _ _ _ 1 . 5 C - -	421	100L
3.4	271.4	3932	2.69	80613	2 5 0		
3	311.86	4516	2.35	80613	2 8 0		
2.6	353.64	5112	2.07	80613	3 0 0		
2.4	390.06	5641	1.88	80613	3 6 0		
2.1	446.71	6455	1.64	80613	4 0 0		
1.9	492.49	7112	1.51	80613	4 5 0		
1.7	556.83	8034	1.34	80613	5 0 0		
1.4	645.58	9302	1.16	80613	6 5 0		
1.2	770.01	11077	0.97	80613	7 3 0		
1.2	801.52	11512	0.93	80613	8 6 0		

NOTE

Other output speeds are available using 2 and 8 pole motors - Consult Application Engineering

SERIES M

SELECTION TABLES

GEARED MOTORS

2.2 kW

4 POLE

N2 R/MIN	i	M2 Nm	Fm	N	Unit Designation	Kg	Motor Size
Output Speed	Ratio	Output Torque	Service Factor	Overhung Load	Column Entry [1] Through [20] Spaces to be filled when entering order	Weight	
379	3.75	53	1.11	1380	M 0 1 2 2 3 . 6 _ M _ _ _ _ 2 . 2 A - -	30	100L
280	5.07	72	0.93	1380	5 . 0		
246	5.76	82	0.87	1360	5 . 6		
396	3.59	51	1.95	3690	M 0 2 2 2 3 . 6 _ M _ _ _ _ 2 . 2 A - -	33	100L
282	5.03	72	1.61	3860	5 . 0		
256	5.55	79	1.52	3910	5 . 6		
225	6.3	90	1.41	3970	6 . 3		
178	8	114	1.19	4000	8 . 0		
156	9.09	130	1.07	4000	9 . 0		
127	11.15	159	0.91	4000	1 1 .		
115	12.37	176	0.84	4000	1 2 .		
396	3.59	51	2.31	3690	M 0 3 2 2 3 . 6 _ M _ _ _ _ 2 . 2 A - -	33	100L
282	5.03	71	1.88	3860	5 . 0		
256	5.55	79	1.77	3910	5 . 6		
225	6.3	89	1.63	3970	6 . 3		
178	8	114	1.4	4000	8 . 0		
156	9.09	130	1.29	4000	9 . 0		
127	11.15	159	1.12	4000	1 1 .		
115	12.37	177	1.05	4000	1 2 .		
101	14.05	201	0.96	4000	1 4 .		
89	15.97	227	0.9	3850	1 6 .		
81	17.58	251	0.83	3640	1 8 .		
398	3.58	51	3.96	4526	M 0 4 2 2 3 . 6 _ M _ _ _ _ 2 . 2 A - -	49	100L
283	5.04	71	3.29	4718	5 . 0		
252	5.65	80	3.09	4800	5 . 6		
225	6.34	90	2.89	4881	6 . 3		
177	8.05	115	2.51	5024	8 . 0		
156	9.13	130	2.29	5095	9 . 0		
131	10.89	156	1.99	5179	1 1 .		
114	12.54	178	1.58	5420	1 2 .		
98	14.58	208	1.42	5594	1 4 .		
87	16.31	232	1.31	5539	1 6 .		
82	17.39	248	1.25	5598	1 8 .		
69	20.61	293	1.09	5764	2 0 .		
65	22	314	1.03	5822	2 2 .		
52	27.3	388	0.86	5983	2 8 .		
177	8.05	115	3.9	4843	M 0 5 2 2 8 . 0 _ M _ _ _ _ 2 . 2 A - -	49	100L
156	9.13	130	3.44	4915	9 . 0		
131	10.89	156	2.88	4998	1 1 .		
114	12.54	179	2.37	5016	1 2 .		
98	14.58	208	2.15	5016	1 4 .		
87	16.31	233	1.93	5431	1 6 .		
82	17.39	248	1.81	5497	1 8 .		
69	20.61	294	1.53	5567	2 0 .		
65	22	314	1.43	5113	2 2 .		
52	27.3	390	1.15	4504	2 8 .		
44	32.19	459	0.98	4522	3 2 .		
40	35.25	501	0.9	3645	3 6 .		
106	13.48	193	3.18	7200	M 0 6 2 2 1 2 . _ M _ _ _ _ 2 . 2 A - -	54	100L
92	15.52	222	2.37	7200	1 4 .		
79	18.05	258	2.31	7200	1 6 .		
71	20.2	288	2.17	7200	1 8 .		
66	21.53	307	2.03	7200	2 0 .		
56	25.51	364	1.72	7200	2 2 .		
52	27.24	389	1.61	7200	2 8 .		
42	33.8	483	1.3	7200	3 2 .		
36	39.86	567	1.1	7200	3 6 .		
33	43.64	622	1.01	7200	4 5 .		
99	14.34	205	3.69	8331	M 0 7 2 2 1 4 . _ M _ _ _ _ 2 . 2 A - -	62	100L
88	16.26	232	3.39	8633	1 6 .		
79	17.94	256	3.1	9020	1 8 .		
69	20.54	293	2.74	8833	2 0 .		
61	23.23	330	2.46	8092	2 2 .		
53	26.93	383	2.15	7680	2 8 .		
44	32.12	457	1.84	8001	3 2 .		
41	35.17	500	1.69	7430	3 6 .		
34	42.21	598	1.44	7261	4 5 .		
29	48.56	687	1.02	7502	5 0 .		
24	58.95	834	0.9	5530	M 0 7 3 2 5 6 . _ M _ _ _ _ 2 . 2 A - -	60	100L
23	62.83	887	0.87	4630	6 3 .		
43	32.97	469	3.47	20190	M 0 8 2 2 3 2 . _ M _ _ _ _ 2 . 2 A - -	94	100L
39	36.21	515	3.2	20215	3 6 .		
32	44.38	631	2.61	18821	4 5 .		
29	48.46	689	2.39	18617	5 0 .		
26	55.8	790	1.95	19279	5 6 .		
24	60.33	846	1.89	18900	M 0 8 3 2 5 6 . _ M _ _ _ _ 2 . 2 A - -	95	100L
22	66.02	930	1.77	18103	6 3 .		
19	74.69	1049	1.57	16927	7 1 .		
17	84.31	1183	1.39	17742	8 0 .		
14	102.2	1437	1.15	14328	1 0 0		
12	119.19	1671	0.99	14531	1 1 2		
11	130.92	1837	0.9	12174	1 2 5		

NOTE
Other output speeds are available using 2 and 8 pole motors - Consult Application Engineering

SERIES M

SELECTION TABLES

GEARED MOTORS

2.2 kW

4 POLE

N2 R/MIN	i	M2 Nm	Fm	N	Unit Designation	Kg	Motor Size
Output Speed	Ratio	Output Torque	Service Factor	Overhung Load	Column Entry <input type="text" value="1"/> Through <input type="text" value="20"/> Spaces to be filled when entering order	Weight	
32	44.44	634	3.89	29615	M 0 9 2 1 4 5 . . M _ _ _ _ 2 . 2 A - -	135	100L
29	49.07	699	3.46	29617	5 0 .		
26	55.18	783	2.56	29563	5 6 .		
23	61.13	870	2.84	29546	6 3 .		
21	68.74	976	2.53	29429	7 1 .		
24	59.85	847	3.06	29523	M 0 9 3 1 5 6 . . M _ _ _ _ 2 . 2 A - -	144	100L
21	66.49	939	2.81	29423	6 3 .		
19	74.26	1049	2.72	29429	7 1 .		
17	82.51	1166	2.45	29376	8 0 .		
15	93.92	1325	1.99	29220	9 0 .		
14	103.68	1462	1.8	29144	1 0 0		
12	116.55	1645	1.74	29082	1 1 2		
11	128.66	1818	1.57	29006	1 2 5		
10	145.2	2040	1.21	28826	1 4 0		
8.9	160.29	2247	1.1	28762	1 6 0		
18	79.08	1112	3.96	49582	M 1 0 3 1 8 0 . . M _ _ _ _ 2 . 2 A - -	193	100L
15	95.44	1346	2.8	49101	9 0 .		
13	109.97	1548	2.43	48771	1 0 0		
13	112.77	1587	2.78	48771	1 1 2		
11	129.94	1828	2.41	48360	1 2 5		
10	135.88	1904	2.18	48326	1 4 0		
9.1	156.57	2196	1.9	47855	1 6 0		
6.5	220.22	3040	1.45	41580	M 1 0 4 1 2 2 5 . M _ _ _ _ 2 . 2 A - -	230	100L
5.9	242.24	3343	1.32	41580	2 5 0		
5.1	278.36	3841	1.15	41580	2 8 0		
4.5	315.65	4349	1.01	41580	3 0 0		
4.1	348.16	4800	0.92	41580	3 6 0		
3.6	398.71	5495	0.8	41580	4 0 0		
13	113.69	1588	4	66923	M 1 3 3 1 1 1 2 . M _ _ _ _ 2 . 2 A - -	263	100L
11	126.62	1768	3.59	66826	1 2 5		
10	139.07	1935	3.34	66726	1 4 0		
9.2	154.89	2155	3	66730	1 6 0		
8.2	173.37	2425	2.62	66636	1 8 0		
7.7	184.46	2584	2.46	66536	2 0 0		
6.7	212.09	2957	2.18	66442	2 2 5		
6.3	226.98	3126	2.03	64632	M 1 3 4 1 2 2 5 . M _ _ _ _ 2 . 2 A - -	305	100L
5.7	249.68	3438	1.85	64632	2 5 0		
5	286.9	3949	1.61	64632	2 8 0		
4.4	325.33	4472	1.42	64632	3 0 0		
4	358.84	4936	1.29	64632	3 6 0		
3.5	410.95	5649	1.12	64632	4 0 0		
3.1	463.22	6365	1	64632	4 5 0		
2.7	523.74	7191	0.88	64632	5 0 0		
6.8	208.15	2903	3.79	80900	M 1 4 3 1 2 0 0 . M _ _ _ _ 2 . 2 A - -	392	100L
6.7	211.96	2951	3.42	80900	2 2 5		
5.8	246.73	3402	3.11	80613	M 1 4 4 1 2 2 5 . M _ _ _ _ 2 . 2 A - -	421	100L
5.3	271.4	3741	2.83	80613	2 5 0		
4.6	311.86	4297	2.47	80613	2 8 0		
4	353.64	4865	2.18	80613	3 0 0		
3.7	390.06	5369	1.97	80613	3 6 0		
3.2	446.71	6145	1.72	80613	4 0 0		
2.9	492.49	6769	1.59	80613	4 5 0		
2.6	556.83	7647	1.41	80613	5 0 0		
2.2	645.58	8856	1.22	80613	6 5 0		
1.9	770.01	10548	1.02	80613	7 3 0		
1.8	801.52	10952	0.97	80613	8 6 0		
1.5	929.27	12686	0.84	80613	1 0 C		

NOTE

Other output speeds are available using 2 and 8 pole motors - Consult Application Engineering

SERIES M

SELECTION TABLES

GEARED MOTORS

2.2 kW

6 POLE

N2 R/MIN	i	M2 Nm	Fm	N	Unit Designation	Kg	Motor Size
Output Speed	Ratio	Output Torque	Service Factor	Overhung Load	Column Entry <input type="text" value="1"/> Through <input type="text" value="20"/> Spaces to be filled when entering order	Weight	
262	3.59	79	1.27	3100	M 0 2 2 2 3 . 6 _ M _ _ _ _ 2 . 2 C - -	46	112M
187	5.03	110	1.05	3100	5 . 0		
169	5.55	121	1.00	3100	5 . 6		
149	6.30	138	0.92	2650	6 . 3		
262	3.59	79	1.50	2300	M 0 3 2 2 3 . 6 _ M _ _ _ _ 2 . 2 C - -	46	112M
187	5.03	110	1.22	2300	5 . 0		
169	5.55	121	1.15	2300	5 . 6		
149	6.30	138	1.07	2300	6 . 3		
118	8.00	175	0.92	2150	8 . 0		
103	9.09	199	0.84	2000	9 . 0		
265	3.58	77	3.02	4780	M 0 4 2 2 3 . 6 _ M _ _ _ _ 2 . 2 C - -	56	112M
188	5.04	108	2.51	5000	5 . 0		
168	5.65	121	2.35	5070	5 . 6		
150	6.34	136	2.15	5130	6 . 3		
118	8.05	172	1.79	5250	8 . 0		
104	9.13	196	1.62	5350	9 . 0		
87	10.89	233	1.43	5540	1 1 .		
76	12.54	268	1.21	5680	1 2 .		
65	14.58	313	1.08	5820	1 4 .		
58	16.31	349	0.97	5920	1 6 .		
55	17.39	373	0.9	5970	1 8 .		
265	3.58	77	3.8	7200	M 0 5 2 2 3 . 6 _ M _ _ _ _ 2 . 2 C - -	56	112M
188	5.04	108	3.53	4820	5 . 0		
168	5.65	121	3.39	4890	5 . 6		
150	6.34	136	3.03	4950	6 . 3		
118	8.05	173	2.6	5060	8 . 0		
104	9.13	196	2.29	5150	9 . 0		
87	10.89	234	1.92	5340	1 1 .		
76	12.54	269	1.58	5480	1 2 .		
65	14.58	313	1.43	5610	1 4 .		
58	16.31	349	1.29	5700	1 6 .		
55	17.39	373	1.21	5750	1 8 .		
46	20.61	442	1.02	5060	2 0 .		
43	22	471	0.95	4450	2 2 .		
152	6.24	134	3.53	7200	M 0 6 2 2 5 . 6 _ M _ _ _ _ 2 . 2 C - -	61	112M
136	6.99	150	3.39	7200	6 . 3		
121	7.85	168	3.03	7200	8 . 0		
95	9.97	214	2.77	7200	9 . 0		
84	11.3	243	2.5	7200	1 1 .		
70	13.48	290	2.15	7200	1 2 .		
61	15.52	333	1.58	7200	1 4 .		
53	18.05	388	1.54	7200	1 6 .		
47	20.2	433	1.44	7200	1 8 .		
44	21.53	462	1.35	7200	2 0 .		
37	25.51	547	1.14	7200	2 2 .		
35	27.24	584	1.07	7200	2 8 .		
28	33.8	724	0.86	7200	3 2 .		
84	11.35	243	3.18	8620	M 0 7 2 2 1 1 . _ M _ _ _ _ 2 . 2 C - -	69	112M
76	12.48	267	2.96	8440	1 2 .		
66	14.34	307	2.63	8126	1 4 .		
58	16.26	348	2.35	7790	1 6 .		
53	17.94	384	2.15	7470	1 8 .		
46	20.54	439	1.9	6963	2 0 .		
41	23.23	496	1.7	6666	2 2 .		
35	26.93	575	1.49	6666	2 8 .		
30	32.12	685	1.26	5217	3 2 .		
27	35.17	749	1.16	5217	3 6 .		
23	42.21	897	0.97	3265	4 5 .		
52	18.26	390	3.48	20000	M 0 8 2 2 1 8 . _ M _ _ _ _ 2 . 2 C - -	101	112M
46	20.66	442	3.3	20000	2 0 .		
41	23.32	500	3.08	20000	2 2 .		
34	28.27	604	2.73	20000	2 8 .		
29	32.97	704	2.34	17987	3 2 .		
26	36.21	773	2.13	17718	3 6 .		
21	44.38	947	1.74	16267	4 5 .		
20	48.46	1033	1.6	15492	5 0 .		
17	55.8	1184	1.31	14699	5 6 .		
16	60.33	1273	1.3	14606	M 0 8 3 2 5 6 . _ M _ _ _ _ 2 . 2 C - -	102	112M
14	66.02	1394	1.18	12236	6 3 .		
13	74.69	1581	1.04	11076	7 1 .		
11	84.31	1780	0.93	9804	8 0 .		
24	40.25	862	2.87	29500	M 0 9 2 1 4 0 . _ M _ _ _ _ 2 . 2 C - -	142	112M
21	44.44	951	2.6	29500	4 5 .		
19	49.07	1049	2.65	29400	5 0 .		
17	55.18	1174	1.66	29390	5 6 .		
16	61.13	1304	1.89	29250	6 3 .		
14	68.74	1464	1.66	28975	7 1 .		

NOTE
Other output speeds are available using 2 and 8 pole motors - Consult Application Engineering

SERIES M

SELECTION TABLES

GEARED MOTORS

2.2 kW

6 POLE

N2 R/MIN	i	M2 Nm	Fm	N	Unit Designation	Kg	Motor Size
Output Speed	Ratio	Output Torque	Service Factor	Overhung Load	Column Entry <input type="text" value="1"/> Through <input type="text" value="20"/> Spaces to be filled when entering order	Weight	
16	59.85	1270	2.08	29200	M 0 9 3 1 5 6 . _ M _ _ _ _ _ 2 . 2 C - -	151	112M
14	66.49	1410	1.87	29100	6 3 .		
13	74.26	1577	1.81	29100	7 1 .		
12	82.51	1751	1.63	29000	8 0 .		
10	93.92	1989	1.33	28800	9 0 .		
9.2	103.68	2198	1.2	28700	1 0 0		
8.2	116.55	2474	1.16	28600	1 1 2		
7.4	128.66	2728	1.05	28500	1 2 5		
6.5	145.2	3067	0.81	28300	1 4 0		
18	51.49	1097	3.53	49500	M 1 0 2 1 5 6 . _ M _ _ _ _ _ 2 . 2 C - -	188	112M
16	57.75	1229	3.38	49400	6 3 .		
15	62.05	1317	3.16	49200	7 1 .		
16	60.23	1275	2.96	49200	M 1 0 3 1 5 6 . _ M _ _ _ _ _ 2 . 2 C - -	205	112M
14	66.93	1418	2.66	49000	6 3 .		
13	71.17	1506	2.93	48900	7 1 .		
12	79.08	1673	2.64	48600	8 0 .		
10	95.44	2019	1.87	47635	9 0 .		
8.6	109.97	2328	1.62	46378	1 0 0		
8.4	112.77	2385	1.85	46425	1 1 2		
7.3	129.94	2746	1.61	46625	1 2 5		
7	135.88	2870	1.45	46450	1 4 0		
6.1	156.57	3299	1.26	46044	1 6 0		
4.3	220.22	4569	0.97	41580	M 1 0 4 1 2 2 5 _ M _ _ _ _ _ 2 . 2 C - -	237	112M
3.9	242.24	5024	0.88	41580	2 5 0		
8.4	113.69	2384	2.66	66600	M 1 3 3 1 1 1 2 _ M _ _ _ _ _ 2 . 2 C - -	270	112M
7.5	126.62	2653	2.39	66531	1 2 5		
6.8	139.07	2907	2.22	66420	1 4 0		
6.1	154.89	3234	2	66373	1 6 0		
5.5	173.37	3638	1.75	66232	1 8 0		
5.2	184.46	3878	1.64	66115	2 0 0		
4.5	212.09	4446	1.45	65962	2 2 5		
4.2	226.98	4696	1.35	64632	M 1 3 4 1 2 2 5 _ M _ _ _ _ _ 2 . 2 C - -	312	112M
3.8	249.68	5164	1.23	64632	2 5 0		
3.3	286.9	5930	1.07	64632	2 8 0		
2.9	325.33	6714	0.95	64632	3 0 0		
2.6	358.84	7410	0.86	64632	3 6 0		
6.7	142.66	2977	3.39	80900	M 1 4 3 1 1 4 0 _ M _ _ _ _ _ 2 . 2 C - -	399	112M
6.1	154.57	3230	3.13	80900	1 6 0		
5.1	185.56	3894	2.82	80900	1 8 0		
4.6	208.15	4359	2.52	80900	2 0 0		
4.5	211.96	4428	2.28	80865	2 2 5		
3.9	246.73	5107	2.07	80613	M 1 4 4 1 2 2 5 _ M _ _ _ _ _ 2 . 2 C - -	428	112M
3.5	271.4	5616	1.89	80613	2 5 0		
3	311.86	6449	1.64	80613	2 8 0		
2.7	353.64	7301	1.45	80613	3 0 0		
2.4	390.06	8057	1.32	80613	3 6 0		
2.1	446.71	9219	1.15	80613	4 0 0		
1.9	492.49	10157	1.06	80613	4 5 0		
1.7	556.83	11473	0.94	80613	5 0 0		
1.5	645.58	13285	0.81	80613	6 5 0		

NOTE

Other output speeds are available using 2 and 8 pole motors - Consult Application Engineering

SERIES M

SELECTION TABLES

GEARED MOTORS

3.0 kW

4 POLE

N2 R/MIN	i	M2 Nm	Fm	N	Unit Designation	Kg	Motor Size
Output Speed	Ratio	Output Torque	Service Factor	Overhung Load	Column Entry [1] Through [20] Spaces to be filled when entering order	Weight	
398	3.59	68	1.46	3100	M 0 2 2 2 3 . 6 _ M _ _ _ _ 3 . 0 A - -	39	100L
284	5.03	96	1.21	3100	5 . 0		
258	5.55	106	1.15	3100	5 . 6		
227	6.30	120	1.06	3100	6 . 3		
179	8.00	152	0.89	2600	8 . 0		
157	9.09	173	0.81	2300	9 . 0		
398	3.59	68	1.73	2300	M 0 3 2 2 3 . 6 _ M _ _ _ _ 3 . 0 A - -	39	100L
284	5.03	96	1.41	2300	5 . 0		
258	5.55	106	1.33	2300	5 . 6		
227	6.30	120	1.23	2300	6 . 3		
179	8.00	152	1.06	2300	8 . 0		
157	9.09	173	0.97	2200	9 . 0		
128	11.15	212	0.84	2000	1 1 .		
398	3.58	69	2.91	4476	M 0 4 2 2 3 . 6 _ M _ _ _ _ 3 . 0 A - -	49	100L
283	5.04	98	2.41	4648	5 . 0		
252	5.65	110	2.26	4720	5 . 6		
225	6.34	123	2.12	4791	6 . 3		
177	8.05	157	1.84	4911	8 . 0		
156	9.13	177	1.68	4968	9 . 0		
131	10.89	212	1.46	5026	1 1 .		
114	12.54	244	1.16	5202	1 2 .		
98	14.58	284	1.04	5343	1 4 .		
87	16.31	317	0.96	5110	1 6 .		
82	17.39	339	0.92	5140	1 8 .		
283	5.04	98	3.87	4395	M 0 5 2 2 5 . 0 _ M _ _ _ _ 3 . 0 A - -	49	100L
252	5.65	110	3.73	4450	5 . 6		
225	6.34	123	3.34	4504	6 . 3		
177	8.05	157	2.86	4733	8 . 0		
156	9.13	178	2.52	4790	9 . 0		
131	10.89	212	2.11	4850	1 1 .		
114	12.54	244	1.74	4855	1 2 .		
98	14.58	284	1.58	4762	1 4 .		
87	16.31	317	1.42	5204	1 6 .		
82	17.39	339	1.33	5254	1 8 .		
69	20.61	401	1.12	5221	2 0 .		
65	22	429	1.05	4500	2 2 .		
52	27.3	532	0.85	3280	2 8 .		
228	6.24	122	3.87	7200	M 0 6 2 2 5 . 6 _ M _ _ _ _ 3 . 0 A - -	54	100L
204	6.99	136	3.73	7200	6 . 3		
182	7.85	153	3.34	7200	8 . 0		
143	9.97	194	3.05	7200	9 . 0		
126	11.3	221	2.73	7200	1 1 .		
106	13.48	263	2.33	7200	1 2 .		
92	15.52	303	1.74	7200	1 4 .		
79	18.05	352	1.69	7200	1 6 .		
71	20.2	394	1.59	7200	1 8 .		
66	21.53	419	1.49	7200	2 0 .		
56	25.51	497	1.26	7200	2 2 .		
52	27.24	530	1.18	7200	2 8 .		
42	33.8	658	0.95	7200	3 2 .		
36	39.86	773	0.81	7200	3 6 .		
126	11.35	221	3.23	7698	M 0 7 2 2 1 1 . _ M _ _ _ _ 3 . 0 A - -	62	100L
114	12.48	243	3.03	7607	1 2 .		
99	14.34	279	2.71	7670	1 4 .		
88	16.26	316	2.48	7956	1 6 .		
79	17.94	349	2.27	8480	1 8 .		
69	20.54	399	2.01	8190	2 0 .		
61	23.23	451	1.8	7040	2 2 .		
53	26.93	523	1.58	6400	2 8 .		
44	32.12	623	1.35	6898	3 2 .		
41	35.17	682	1.24	6012	3 6 .		
34	42.21	815	1.06	5750	4 5 .		
78	18.26	354	3.83	18200	M 0 8 2 2 1 8 . _ M _ _ _ _ 3 . 0 A - -	94	100L
69	20.66	401	3.64	18800	2 0 .		
61	23.32	456	3.37	19500	2 2 .		
50	28.27	548	2.9	20000	2 8 .		
43	32.97	640	2.55	18667	3 2 .		
39	36.21	702	2.35	18492	3 6 .		
32	44.38	860	1.92	17475	4 5 .		
29	48.46	939	1.76	17036	5 0 .		
26	55.8	1078	1.43	18755	5 6 .		
24	60.33	1154	1.39	18100	M 0 8 3 2 5 6 . _ M _ _ _ _ 3 . 0 A - -	95	100L
22	66.02	1268	1.3	16724	6 3 .		
19	74.69	1430	1.15	14693	7 1 .		
17	84.31	1614	1.02	16100	8 0 .		
14	102.2	1959	0.84	11200	1 0 0		
40	35.67	693	3.37	29600	M 0 9 2 1 3 6 . _ M _ _ _ _ 3 . 0 A - -	135	100L
35	40.25	783	3.15	29600	4 0 .		
32	44.44	865	2.85	29492	4 5 .		
29	49.07	953	2.54	29478	5 0 .		
26	55.18	1068	1.88	29407	5 6 .		
23	61.13	1187	2.08	29370	6 3 .		
21	68.74	1332	1.85	29234	7 1 .		

NOTE
Other output speeds are available using 2 and 8 pole motors - Consult Application Engineering

SERIES M

SELECTION TABLES

GEARED MOTORS

3.0 kW

4 POLE

N2 R/MIN	i	M2 Nm	Fm	N	Unit Designation	Kg	Motor Size
Output Speed	Ratio	Output Torque	Service Factor	Overhung Load	Column Entry <input type="text" value="1"/> Through <input type="text" value="20"/> Spaces to be filled when entering order	Weight	
24	59.85	1155	2.24	29335	M 0 9 3 1 5 6 . . . M 3 . 0 A - -	144	100L
21	66.49	1281	2.06	29235	6 3 . .		
19	74.26	1431	2	29194	7 1 . .		
17	82.51	1590	1.8	29120	8 0 . .		
15	93.92	1806	1.46	28944	9 0 . .		
14	103.68	1994	1.32	28813	1 0 0 .		
12	116.55	2244	1.27	28779	1 1 2 .		
11	128.66	2480	1.15	28648	1 2 5 .		
10	145.2	2782	0.89	28400	1 4 0 .		
8.9	160.29	3065	0.81	28300	1 6 0 .		
28	51.49	1001	3.87	46600	M 1 0 2 1 5 6 . . . M 3 . 0 A - -	181	100L
25	57.75	1113	3.73	48400	6 3 . .		
23	62.05	1198	3.47	49452	7 1 . .		
24	60.23	1157	3.26	29500	M 1 0 3 1 5 6 . . . M 3 . 0 A - -	193	100L
21	66.93	1285	2.93	29500	6 3 . .		
20	71.17	1366	3.23	29500	7 1 . .		
18	79.08	1517	2.91	48921	8 0 . .		
15	95.44	1835	2.05	48286	9 0 . .		
13	109.97	2111	1.79	47825	1 0 0 .		
13	112.77	2164	2.04	47825	1 1 2 .		
11	129.94	2492	1.77	47287	1 2 5 .		
10	135.88	2596	1.6	47214	1 4 0 .		
9.1	156.57	2995	1.39	46586	1 6 0 .		
6.5	220.22	4145	1.06	41580	M 1 0 4 1 2 2 5 . . . M 3 . 0 A - -	230	100L
5.9	242.24	4559	0.97	41580	2 5 0 .		
5.1	278.36	5237	0.84	41580	2 8 0 .		
16	90.75	1736	3.57	66900	M 1 3 3 1 9 0 . . . M 3 . 0 A - -	263	100L
14	101.07	1933	3.21	66700	1 0 0 .		
13	113.69	2165	2.93	66738	1 1 2 .		
11	126.62	2410	2.63	66611	1 2 5 .		
10	139.07	2639	2.45	66511	1 4 0 .		
9.2	154.89	2938	2.2	66484	1 6 0 .		
8.2	173.37	3307	1.92	66345	1 8 0 .		
7.7	184.46	3524	1.8	66245	2 0 0 .		
6.7	212.09	4032	1.6	66103	2 2 5 .		
6.3	226.98	4263	1.49	64632	M 1 3 4 1 2 2 5 . . . M 3 . 0 A - -	305	100L
5.7	249.68	4689	1.35	64632	2 5 0 .		
5	286.9	5386	1.18	64632	2 8 0 .		
4.4	325.33	6098	1.04	64632	3 0 0 .		
4	358.84	6731	0.94	64632	3 6 0 .		
3.5	410.95	7704	0.82	64632	4 0 0 .		
10	142.66	2704	3.73	80900	M 1 4 3 1 1 4 0 . . . M 3 . 0 A - -	392	100L
9.2	154.57	2936	3.44	80900	1 6 0 .		
7.7	185.56	3538	3.11	80900	1 8 0 .		
6.8	208.15	3959	2.78	80900	2 0 0 .		
6.7	211.96	4025	2.51	80900	2 2 5 .		
5.8	246.73	4639	2.28	80613	M 1 4 4 1 2 2 5 . . . M 3 . 0 A - -	421	100L
5.3	271.4	5102	2.08	80613	2 5 0 .		
4.6	311.86	5859	1.81	80613	2 8 0 .		
4	353.64	6634	1.6	80613	3 0 0 .		
3.7	390.06	7322	1.45	80613	3 6 0 .		
3.2	446.71	8379	1.26	80613	4 0 0 .		
2.9	492.49	9231	1.17	80613	4 5 0 .		
2.6	556.83	10428	1.03	80613	5 0 0 .		
2.2	645.58	12077	0.89	80613	6 5 0 .		

3.0 kW

6 POLE

260	3.68	107	2.87	8020	M 0 7 2 2 3 . 6 . . . M 3 . 0 C - -	88	132S
187	5.09	148	2.87	8470	5 . 0 .		
167	5.72	166	2.87	8620	5 . 6 .		
152	6.29	183	2.87	8750	6 . 3 .		
116	8.22	239	2.87	9090	8 . 0 .		
102	9.34	271	2.73	9240	9 . 0 .		
84	11.35	330	2.34	7950	1 1 . .		
77	12.48	363	2.18	7683	1 2 . .		
67	14.34	417	1.94	7218	1 4 . .		
59	16.26	472	1.73	6718	1 6 . .		
53	17.94	522	1.58	6243	1 8 . .		
46	20.54	596	1.4	5491	2 0 . .		
41	23.23	673	1.26	5050	2 2 . .		
35	26.93	781	1.1	5050	2 8 . .		
30	32.12	930	0.93	2898	3 2 . .		
27	35.17	1017	0.85	2898	3 6 . .		

NOTE

Other output speeds are available using 2 and 8 pole motors - Consult Application Engineering

SERIES M

SELECTION TABLES

GEARED MOTORS

3.0 kW

6 POLE

N2 R/MIN	i	M2 Nm	Fm	N	Unit Designation	Kg	Motor Size
Output Speed	Ratio	Output Torque	Service Factor	Overhung Load	Column Entry <input type="text" value="1"/> Through <input type="text" value="20"/> Spaces to be filled when entering order	Weight	
63	15.04	436	3.55	19300	M 0 8 2 2 1 4 . . . M 3 . 0 C - -	121	132S
57	16.69	483	2.93	19900	1 6 .		
52	18.26	529	2.57	18460	1 8 .		
46	20.66	599	2.43	18233	2 0 .		
41	23.32	678	2.27	18181	2 2 .		
34	28.27	819	2.01	18181	2 8 .		
29	32.97	955	1.73	15687	3 2 .		
26	36.21	1049	1.57	15111	3 6 .		
22	44.38	1285	1.28	13552	4 5 .		
20	48.46	1401	1.18	12214	5 0 .		
17	55.8	1606	0.96	11775	5 6 .		
16	60.33	1727	0.96	10683	M 0 8 3 2 5 6 . . M 3 . 0 C - -	126	132S
14	66.02	1891	0.87	7953	6 3 .		
37	26.04	758	3.48	29500	M 0 9 2 1 2 5 . . M 3 . 0 C - -	162	132S
33	28.74	837	3.15	29500	2 8 .		
30	32.31	940	2.83	29500	3 2 .		
27	35.67	1038	2.59	29400	3 6 .		
24	40.25	1169	2.11	28790	4 0 .		
21	44.44	1290	1.91	29303	4 5 .		
19	49.07	1423	1.95	29067	5 0 .		
17	55.18	1593	1.22	29150	5 6 .		
16	61.13	1769	1.4	28995	6 3 .		
14	68.74	1985	1.22	28520	7 1 .		
22	42.7	1242	3.35	49400	M 1 0 2 1 4 5 . . M 3 . 0 C - -	208	132S
20	47.93	1386	3.04	49100	5 0 .		
19	51.49	1488	2.6	48845	5 6 .		
17	57.75	1668	2.49	48681	6 3 .		
15	62.05	1787	2.33	48436	7 1 .		
15	64.17	1851	3.35	66800	M 1 3 3 1 6 3 . . M 3 . 0 C - -	290	132S
13	71.32	2039	3.11	66700	7 1 .		
12	80.39	2298	2.76	66600	8 0 .		
11	90.75	2593	2.39	66600	9 0 .		
9.4	101.07	2885	2.15	66500	1 0 0		
8.4	113.69	3234	1.96	66328	1 1 2		
7.5	126.62	3599	1.76	66225	1 2 5		
6.9	139.07	3943	1.64	66100	1 4 0		
6.2	154.89	4387	1.47	66000	1 6 0		
5.5	173.37	4935	1.29	65812	1 8 0		
5.2	184.46	5260	1.21	65675	2 0 0		
4.5	212.09	6031	1.07	65462	2 2 5		
7.6	124.89	3551	3.1	80900	M 1 4 3 1 1 1 2 . M 3 . 0 C - -	419	132S
7.1	135.31	3852	2.86	80900	1 2 5		
6.7	142.66	4039	2.5	80900	1 4 0		
6.2	154.57	4382	2.3	80900	1 6 0		
5.1	185.56	5282	2.08	80900	1 8 0		
4.6	208.15	5913	1.86	80854	2 0 0		
4.5	211.96	6007	1.68	80825	2 2 5		

4.0 kW

4 POLE

398	3.59	91	1.10	3100	M 0 2 2 2 3 . 6 . M 4 . 0 A - -	46	112M
284	5.03	128	0.91	2650	5 . 0		
258	5.55	141	0.86	2400	5 . 6		
398	3.59	91	1.30	2300	M 0 3 2 2 3 . 6 . M 4 . 0 A - -	46	112M
284	5.03	128	1.06	2300	5 . 0		
258	5.55	141	0.99	2300	5 . 6		
227	6.30	160	0.92	2100	6 . 3		
400	3.58	92	2.19	4413	M 0 4 2 2 3 . 6 . M 4 . 0 A - -	56	112M
285	5.04	129	1.82	4561	5 . 0		
254	5.65	145	1.71	4620	5 . 6		
226	6.34	163	1.6	4678	6 . 3		
178	8.05	208	1.39	4770	8 . 0		
157	9.13	235	1.27	4809	9 . 0		
132	10.89	281	1.1	4835	1 1 .		
114	12.54	323	0.88	4930	1 2 .		
400	3.58	92	3.17	4160	M 0 5 2 2 3 . 6 . M 4 . 0 A - -	56	112M
285	5.04	130	2.92	4345	5 . 0		
254	5.65	146	2.82	4394	5 . 6		
226	6.34	163	2.52	4438	6 . 3		
178	8.05	208	2.16	4596	8 . 0		
157	9.13	236	1.9	4634	9 . 0		
132	10.89	281	1.6	4666	1 1 .		
114	12.54	324	1.31	4653	1 2 .		
98	14.58	377	1.19	4445	1 4 .		
88	16.31	421	1.07	4920	1 6 .		
83	17.39	449	1	4950	1 8 .		
70	20.61	531	0.85	4790	2 0 .		

NOTE

Other output speeds are available using 2 and 8 pole motors - Consult Application Engineering

SERIES M

SELECTION TABLES

GEARED MOTORS

4.0 kW

4 POLE

N2 R/MIN	i	M2 Nm	Fm	N	Unit Designation	Kg	Motor Size
Output Speed	Ratio	Output Torque	Service Factor	Overhung Load	Column Entry 1 Through 20 Spaces to be filled when entering order	Weight	
323	4.44	114	3.17	7200	M 0 6 2 2 5 . 0 _ M _ _ _ _ 4 . 0 A - -	61	112M
230	6.24	162	2.92	7200	5 . 6		
205	6.99	180	2.82	7200	6 . 3		
183	7.85	202	2.52	7200	8 . 0		
144	9.97	258	2.3	7200	9 . 0		
127	11.3	292	2.06	7200	1 1 .		
106	13.48	348	1.76	7200	1 2 .		
92	15.52	401	1.31	7200	1 4 .		
79	18.05	466	1.28	7200	1 6 .		
71	20.2	521	1.2	7200	1 8 .		
67	21.53	556	1.13	7200	2 0 .		
56	25.51	658	0.95	7200	2 2 .		
53	27.24	702	0.89	7200	2 8 .		
390	3.68	94	3.24	7490	M 0 7 2 2 3 . 6 _ M _ _ _ _ 4 . 0 A - -	69	112M
282	5.09	131	3.24	7780	5 . 0		
251	5.72	147	3.24	7930	5 . 6		
228	6.29	161	3.24	8050	6 . 3		
175	8.22	213	2.97	8370	8 . 0		
154	9.34	241	2.75	8510	9 . 0		
126	11.35	293	2.44	7128	1 1 .		
115	12.48	321	2.29	6943	1 2 .		
100	14.34	370	2.04	6844	1 4 .		
88	16.26	419	1.88	7110	1 6 .		
80	17.94	463	1.71	7804	1 8 .		
70	20.54	529	1.52	7385	2 0 .		
62	23.23	597	1.36	5724	2 2 .		
53	26.93	693	1.19	4800	2 8 .		
45	32.12	826	1.02	5520	3 2 .		
41	35.17	903	0.94	4240	3 6 .		
86	16.69	428	3.32	17400	M 0 8 2 2 1 6 . _ M _ _ _ _ 4 . 0 A - -	101	112M
79	18.26	469	2.89	16986	1 8 .		
69	20.66	531	2.75	17340	2 0 .		
62	23.32	604	2.55	17752	2 2 .		
51	28.27	726	2.19	17785	2 8 .		
44	32.97	847	1.92	16763	3 2 .		
40	36.21	930	1.77	16338	3 6 .		
32	44.38	1139	1.45	15792	4 5 .		
30	48.46	1244	1.33	15060	5 0 .		
26	55.8	1427	1.08	18100	5 6 .		
24	60.33	1528	1.05	17100	M 0 8 3 2 5 6 . _ M _ _ _ _ 4 . 0 A - -	102	112M
22	66.02	1679	0.98	15000	6 3 .		
19	74.69	1894	0.87	11900	7 1 .		
55	26.04	671	3.93	27400	M 0 9 2 1 2 5 . _ M _ _ _ _ 4 . 0 A - -	142	112M
50	28.74	740	3.56	28200	2 8 .		
44	32.31	837	2.77	29300	3 2 .		
40	35.67	918	2.55	28783	3 6 .		
36	40.25	1037	2.38	29111	4 0 .		
32	44.44	1146	2.15	29338	4 5 .		
29	49.07	1262	1.92	29305	5 0 .		
26	55.18	1415	1.42	29212	5 6 .		
23	61.13	1572	1.57	29151	6 3 .		
21	68.74	1763	1.4	28990	7 1 .		
24	59.85	1530	1.69	29100	M 0 9 3 1 5 6 . _ M _ _ _ _ 4 . 0 A - -	151	112M
22	66.49	1696	1.56	29000	6 3 .		
19	74.26	1895	1.51	28900	7 1 .		
17	82.51	2105	1.36	28800	8 0 .		
15	93.92	2392	1.1	28600	9 0 .		
14	103.68	2641	1	28400	1 0 0		
12	116.55	2971	0.96	28400	1 1 2		
11	128.66	3283	0.87	28200	1 2 5		
34	42.7	1098	3.79	43600	M 1 0 2 1 4 5 . _ M _ _ _ _ 4 . 0 A - -	188	112M
30	47.93	1227	3.41	45100	5 0 .		
28	51.49	1325	2.92	46066	5 6 .		
25	57.75	1474	2.82	47800	6 3 .		
23	62.05	1586	2.62	48813	7 1 .		
24	60.23	1532	2.46	29411	M 1 0 3 1 5 6 . _ M _ _ _ _ 4 . 0 A - -	205	112M
21	66.93	1702	2.21	29411	6 3 .		
20	71.17	1809	2.44	29411	7 1 .		
18	79.08	2009	2.19	48094	8 0 .		
15	95.44	2430	1.55	47267	9 0 .		
13	109.97	2795	1.35	46641	1 0 0		
13	112.77	2865	1.54	46641	1 1 2		
11	129.94	3300	1.34	45946	1 2 5		
11	135.88	3438	1.21	45824	1 4 0		
9.2	156.57	3965	1.05	45000	1 6 0		
6.5	220.22	5489	0.8	41580	M 1 0 4 1 2 2 5 _ M _ _ _ _ 4 . 0 A - -	237	112M

NOTE

Other output speeds are available using 2 and 8 pole motors - Consult Application Engineering

SERIES M

SELECTION TABLES

GEARED MOTORS

4.0 kW

4 POLE

N2 R/MIN	i	M2 Nm	Fm	N	Unit Designation	Kg	Motor Size
Output Speed	Ratio	Output Torque	Service Factor	Overhung Load	Column Entry [1] Through [20] Spaces to be filled when entering order	Weight	
22	64.17	1637	3.79	66900	M 1 3 3 1 6 3 _ _ M _ _ _ _ 4 . 0 A _ _	270	112M
20	71.32	1807	3.51	66800	7 1 .		
18	80.39	2036	3.12	66841	8 0 .		
16	90.75	2299	2.7	66800	9 0 .		
14	101.07	2559	2.42	66611	1 0 0		
13	113.69	2867	2.21	66507	1 1 2		
11	126.62	3192	1.99	66342	1 2 5		
10	139.07	3495	1.85	66242	1 4 0		
9.3	154.89	3891	1.66	66176	1 6 0		
8.3	173.37	4379	1.45	65981	1 8 0		
7.8	184.46	4666	1.36	65881	2 0 0		
6.8	212.09	5339	1.21	65678	2 2 5		
6.3	226.98	5645	1.12	64632	M 1 3 4 1 2 2 5 _ M _ _ _ _ 4 . 0 A _ _	312	112M
5.7	249.68	6208	1.02	64632	2 5 0		
5	286.9	7131	0.89	64632	2 8 0		
11	124.89	3153	3.49	80900	M 1 4 3 1 1 1 2 _ M _ _ _ _ 4 . 0 A _ _	399	112M
11	135.31	3419	3.22	80900	1 2 5		
10	142.66	3580	2.82	80900	1 4 0		
9.3	154.57	3887	2.6	80900	1 6 0		
7.7	185.56	4684	2.35	80900	1 8 0		
6.9	208.15	5242	2.1	80900	2 0 0		
6.8	211.96	5329	1.9	80900	2 2 5		
5.8	246.73	6143	1.72	80613	M 1 4 4 1 2 2 5 _ M _ _ _ _ 4 . 0 A _ _	428	112M
5.3	271.4	6755	1.57	80613	2 5 0		
4.6	311.86	7758	1.37	80613	2 8 0		
4.1	353.64	8784	1.21	80613	3 0 0		
3.7	390.06	9694	1.09	80613	3 6 0		
3.2	446.71	11095	0.95	80613	4 0 0		
2.9	492.49	12222	0.88	80613	4 5 0		

4.0 kW

6 POLE

261	3.68	141	2.16	7888	M 0 7 2 2 3 . 6 _ M _ _ _ _ 4 . 0 C _ _	92	132M
188	5.09	196	2.16	8290	5 . 0		
168	5.72	221	2.16	8420	5 . 6		
153	6.29	243	2.16	8522	6 . 3		
117	8.22	317	2.16	8334	8 . 0		
103	9.34	360	2.06	8232	9 . 0		
85	11.35	437	1.76	7114	1 .		
77	12.48	482	1.64	6738	1 2 .		
67	14.34	553	1.46	6053	1 4 .		
59	16.26	626	1.3	5379	1 6 .		
54	17.94	692	1.19	4710	1 8 .		
47	20.54	791	1.06	3650	2 0 .		
41	23.23	893	0.95	3030	2 2 .		
36	26.93	1036	0.83	3030	2 8 .		
115	8.33	322	3.97	16700	M 0 8 2 2 8 . 0 _ M _ _ _ _ 4 . 0 C _ _	125	132M
103	9.35	359	3.7	17000	9 . 0		
84	11.47	443	3.22	17500	1 1 .		
74	12.92	498	2.95	18100	1 2 .		
64	15.04	579	2.67	17670	1 4 .		
58	16.69	641	2.21	17998	1 6 .		
53	18.26	702	1.93	16537	1 8 .		
46	20.66	795	1.84	16025	2 0 .		
41	23.32	900	1.71	15909	2 2 .		
34	28.27	1087	1.52	15909	2 8 .		
29	32.97	1266	1.3	12812	3 2 .		
27	36.21	1392	1.18	11852	3 6 .		
22	44.38	1705	0.97	10159	4 5 .		
20	48.46	1859	0.89	8116	5 0 .		
52	18.43	713	3.7	27900	M 0 9 2 1 1 8 . _ M _ _ _ _ 4 . 0 C _ _	166	132M
47	20.59	800	3.58	29000	2 0 .		
42	22.87	886	3.22	29500	2 2 .		
37	26.04	1005	2.62	28425	2 5 .		
33	28.74	1110	2.38	28275	2 8 .		
30	32.31	1247	2.13	28250	3 2 .		
27	35.67	1377	1.95	27958	3 6 .		
24	40.25	1551	1.59	27904	4 0 .		
22	44.44	1712	1.44	29058	4 5 .		
20	49.07	1887	1.47	28652	5 0 .		
17	55.18	2113	0.92	28850	5 6 .		
16	61.13	2346	1.05	28677	6 3 .		
14	68.74	2634	0.92	27952	7 1 .		
32	29.99	1160	3.25	44300	M 1 0 2 1 2 8 . _ M _ _ _ _ 4 . 0 C _ _	212	132M
31	30.76	1183	3.72	44700	3 2 .		
27	35.44	1367	3.22	46600	3 6 .		
26	37.06	1422	2.92	47300	4 0 .		
22	42.7	1647	2.53	48566	4 5 .		
20	47.93	1838	2.3	47958	5 0 .		
19	51.49	1974	1.96	48027	5 6 .		
17	57.75	2212	1.88	47784	6 3 .		
15	62.05	2370	1.75	47481	7 1 .		
16	60.23	2295	1.64	49200	M 1 0 3 1 5 6 . _ M _ _ _ _ 4 . 0 C _ _	239	132M
14	66.93	2551	1.48	49000	6 3 .		
13	71.17	2709	1.63	48900	7 1 .		
12	79.08	3010	1.47	46358	8 0 .		
10	95.44	3633	1.04	44125	9 0 .		
8.7	109.97	4188	0.9	40408	1 0 0		
8.5	112.77	4291	1.03	40575	1 1 2		
7.4	129.94	4941	0.89	42575	1 2 5		
7.1	135.88	5164	0.81	42113	1 4 0		

NOTE

Other output speeds are available using 2 and 8 pole motors - Consult Application Engineering

SERIES M

SELECTION TABLES

GEARED MOTORS

4.0 kW

6 POLE

N2 R/MIN	i	M2 Nm	Fm	N	Unit Designation	Kg	Motor Size		
Output Speed	Ratio	Output Torque	Service Factor	Overhung Load	Column Entry <input type="text" value="1"/> Through <input type="text" value="20"/> Spaces to be filled when entering order	Weight			
17	56.93	2175	2.85	66700	M 1 3 3 1 5 6 . _ M _ _ _ _ 4 . 0 C - -	294	132M		
15	64.17	2455	2.53	66741	6 3 .				
13	71.32	2705	2.35	66616	7 1 .				
12	80.39	3049	2.08	66516	8 0 .				
11	90.75	3439	1.8	66437	9 0 .				
9.5	101.07	3827	1.62	66325	1 0 0				
8.4	113.69	4290	1.48	65988	1 1 2				
7.6	126.62	4774	1.33	65841	1 2 5				
6.9	139.07	5230	1.24	65700	1 4 0				
6.2	154.89	5819	1.11	65533	1 6 0				
5.5	173.37	6546	0.97	65287	1 8 0				
5.2	184.46	6978	0.91	65125	2 0 0				
4.5	212.09	8000	0.81	64837	2 2 5				
10	94.35	3580	3.1	80900	M 1 4 3 1 9 0 . _ M _ _ _ _ 4 . 0 C - -			423	132M
9.4	102.23	3860	2.88	80900	1 0 0				
7.7	124.89	4710	2.34	80900	1 1 2				
7.1	135.31	5110	2.15	80900	1 2 5				
6.7	142.66	5358	1.88	80900	1 4 0				
6.2	154.57	5812	1.74	80900	1 6 0				
5.2	185.56	7006	1.57	80900	1 8 0				
4.6	208.15	7843	1.4	80798	2 0 0				
4.5	211.96	7968	1.27	80775	2 2 5				

5.5 kW

4 POLE

399	3.58	127	1.59	4320	M 0 4 2 2 3 . 6 _ M _ _ _ _ 5 . 5 A - -	70	132S
284	5.04	179	1.32	4430	5 . 0		
253	5.65	200	1.24	4470	5 . 6		
226	6.34	226	1.16	4510	6 . 3		
178	8.05	287	1.01	4560	8 . 0		
157	9.13	325	0.92	4570	9 . 0		
399	3.58	127	2.3	4160	M 0 5 2 2 3 . 6 _ M _ _ _ _ 5 . 5 A - -	70	132S
284	5.04	180	2.12	4270	5 . 0		
253	5.65	201	2.04	4310	5 . 6		
226	6.34	225	1.83	4340	6 . 3		
178	8.05	287	1.56	4390	8 . 0		
157	9.13	326	1.38	4400	9 . 0		
131	10.89	389	1.16	4390	1 1 .		
114	12.54	447	0.95	4350	1 2 .		
98	14.58	520	0.86	3970	1 4 .		
322	4.44	157	2.3	7200	M 0 6 2 2 5 . 0 _ M _ _ _ _ 5 . 5 A - -		
229	6.24	223	2.12	7200	5 . 6		
204	6.99	249	2.04	7200	6 . 3		
182	7.85	279	1.83	7200	8 . 0		
143	9.97	356	1.67	7200	9 . 0		
127	11.3	403	1.5	7200	1 1 .		
106	13.48	480	1.27	7200	1 2 .		
92	15.52	554	0.95	7200	1 4 .		
79	18.05	644	0.93	7200	1 6 .		
71	20.2	719	0.87	7200	1 8 .		
66	21.53	767	0.82	7200	2 0 .		
392	3.68	129	2.37	7393	M 0 7 2 2 3 . 6 _ M _ _ _ _ 5 . 5 A - -	88	132S
283	5.09	179	2.37	7647	5 . 0		
252	5.72	201	2.37	7709	5 . 6		
229	6.29	221	2.37	7732	6 . 3		
175	8.22	292	2.17	7722	8 . 0		
154	9.34	330	2	7667	9 . 0		
127	11.35	401	1.78	6273	1 1 .		
115	12.48	441	1.67	5948	1 2 .		
100	14.34	507	1.49	5604	1 4 .		
89	16.26	574	1.37	5840	1 6 .		
80	17.94	634	1.25	6791	1 8 .		
70	20.54	725	1.11	6178	2 0 .		
62	23.23	818	0.99	3751	2 2 .		
53	26.93	949	0.87	2400	2 8 .		
173	8.33	295	3.95	15336	M 0 8 2 2 8 . 0 _ M _ _ _ _ 5 . 5 A - -	121	132S
154	9.35	331	3.68	15648	9 . 0		
126	11.47	405	3.23	16175	1 1 .		
111	12.92	455	2.94	16393	1 2 .		
96	15.04	534	2.65	16821	1 4 .		
86	16.69	586	2.42	15526	1 6 .		
79	18.26	643	2.11	15166	1 8 .		
70	20.66	728	2	15150	2 0 .		
62	23.32	828	1.86	15130	2 2 .		
51	28.27	994	1.6	14463	2 8 .		
44	32.97	1161	1.4	13907	3 2 .		
40	36.21	1274	1.29	13107	3 6 .		
32	44.38	1562	1.06	13268	4 5 .		
30	48.46	1704	0.97	12097	5 0 .		

NOTE

Other output speeds are available using 2 and 8 pole motors - Consult Application Engineering

SERIES M

SELECTION TABLES

GEARED MOTORS

5.5 kW

4 POLE

N2 R/MIN	i	M2 Nm	Fm	N	Unit Designation	Kg	Motor Size
Output Speed	Ratio	Output Torque	Service Factor	Overhung Load	Column Entry [1] Through [20] Spaces to be filled when entering order	Weight	
70	20.59	728	3.88	25256	M 0 9 2 1 2 0 . _ M _ _ _ _ 5 . 5 A - -	162	132S
63	22.87	812	3.52	26068	2 2 .		
55	26.04	919	2.87	26609	2 5 .		
50	28.74	1015	2.6	27177	2 8 .		
45	32.31	1147	2.02	28168	3 2 .		
40	35.67	1258	1.86	27558	3 6 .		
36	40.25	1421	1.74	28377	4 0 .		
32	44.44	1570	1.57	29107	4 5 .		
29	49.07	1729	1.4	29046	5 0 .		
26	55.18	1939	1.04	28919	5 6 .		
24	61.13	2154	1.15	28821	6 3 .		
21	68.74	2416	1.02	28624	7 1 .		
48	29.99	1059	3.56	38534	M 1 0 2 1 2 8 . _ M _ _ _ _ 5 . 5 A - -	208	132S
41	35.44	1252	3.52	40553	3 6 .		
39	37.06	1309	3.18	41131	4 0 .		
34	42.7	1505	2.76	42931	4 5 .		
30	47.93	1681	2.49	44336	5 0 .		
28	51.49	1816	2.13	45266	5 6 .		
25	57.75	2020	2.06	46900	6 3 .		
23	62.05	2173	1.91	47854	7 1 .		
24	60.23	2100	1.79	29277	M 1 0 3 1 5 6 . _ M _ _ _ _ 5 . 5 A - -	235	132S
22	66.93	2332	1.62	29277	6 3 .		
20	71.17	2479	1.78	29277	7 1 .		
18	79.08	2753	1.6	46853	8 0 .		
15	95.44	3329	1.13	45738	9 0 .		
13	109.97	3831	0.98	44866	1 0 0		
13	112.77	3926	1.12	44866	1 1 2		
11	129.94	4522	0.98	43934	1 2 5		
11	135.88	4711	0.88	43739	1 4 0		
25	56.93	1981	3.12	66701	M 1 3 3 1 5 6 . _ M _ _ _ _ 5 . 5 A - -	290	132S
22	64.17	2244	2.76	66848	6 3 .		
20	71.32	2476	2.56	66731	7 1 .		
18	80.39	2791	2.28	66754	8 0 .		
16	90.75	3150	1.97	66650	9 0 .		
14	101.07	3507	1.77	66477	1 0 0		
13	113.69	3929	1.62	66161	1 1 2		
11	126.62	4374	1.45	65938	1 2 5		
10	139.07	4789	1.35	65838	1 4 0		
9.3	154.89	5331	1.21	65715	1 6 0		
8.3	173.37	6001	1.06	65436	1 8 0		
7.8	184.46	6394	0.99	65336	2 0 0		
6.8	212.09	7316	0.88	65042	2 2 5		
17	86.76	3000	3.67	80900	M 1 4 3 1 8 0 . _ M _ _ _ _ 5 . 5 A - -	419	132S
15	94.35	3269	3.39	80900	9 0 .		
14	102.23	3553	3.12	80900	1 0 0		
12	124.89	4320	2.55	80900	1 1 2		
11	135.31	4686	2.35	80900	1 2 5		
10	142.66	4906	2.06	80900	1 4 0		
9.3	154.57	5327	1.9	80900	1 6 0		
7.8	185.56	6419	1.71	80900	1 8 0		
6.9	208.15	7183	1.53	80900	2 0 0		
6.8	211.96	7302	1.38	80900	2 2 5		
5.8	246.73	8476	1.25	80613	M 1 4 4 1 2 2 5 _ M _ _ _ _ 5 . 5 A - -	442	132S
5.3	271.4	9321	1.14	80613	2 5 0		
4.6	311.86	10705	0.99	80613	2 8 0		
4	353.64	12121	0.87	80613	3 0 0		

NOTE
Other output speeds are available using 2 and 8 pole motors - Consult Application Engineering

SERIES M

SELECTION TABLES

GEARED MOTORS

5.5 kW

6 POLE

N2 R/MIN	i	M2 Nm	Fm	N	Unit Designation	Kg	Motor Size
Output Speed	Ratio	Output Torque	Service Factor	Overhung Load	Column Entry 1 Through 20 Spaces to be filled when entering order	Weight	
761	1.26	68	1.57	4600	M 0 7 1 2 1 . 2 _ M _ _ _ _ 5 . 5 C _ _	78	132M
261	3.68	195	1.57	7690	M 0 7 2 2 3 . 6 _ M _ _ _ _ 5 . 5 C _ _	92	132M
188	5.09	270	1.57	8020			
168	5.72	303	1.57	8120			
153	6.29	334	1.57	8180			
117	8.22	436	1.57	7200			
103	9.34	495	1.5	6720			
85	11.35	602	1.28	5860			
77	12.48	662	1.2	5320			
67	14.34	760	1.06	4379			
59	16.26	861	0.95	3369			
54	17.94	952	0.87	2409			
261	3.68	195	3.16	14328	M 0 8 2 2 3 . 6 _ M _ _ _ _ 5 . 5 C _ _	125	132M
184	5.21	276	3.16	15164			
166	5.79	307	3.16	15442			
149	6.44	341	3.16	15614			
115	8.33	442	2.89	15800			
103	9.35	494	2.69	15821			
84	11.47	609	2.35	15777			
74	12.92	685	2.15	15980			
64	15.04	796	1.95	15225			
58	16.69	882	1.61	15146			
53	18.26	966	1.41	13651			
46	20.66	1094	1.33	12713			
41	23.32	1238	1.24	12500			
34	28.27	1495	1.1	12500			
29	32.97	1741	0.95	8500			
27	36.21	1914	0.86	6963			
66	14.53	774	3.69	25700	M 0 9 2 1 1 4 . _ M _ _ _ _ 5 . 5 C _ _	166	132M
58	16.59	885	2.98	25816			
52	18.43	981	2.69	26386			
47	20.59	1100	2.6	27367			
42	22.87	1219	2.35	27621			
37	26.04	1382	1.91	26812			
33	28.74	1526	1.73	26437			
30	32.31	1715	1.55	26375			
27	35.67	1894	1.42	25795			
24	40.25	2132	1.16	26575			
22	44.44	2354	1.05	28690			
20	49.07	2595	1.07	28030			
32	29.99	1595	2.36	42700	M 1 0 2 1 2 8 . _ M _ _ _ _ 5 . 5 C _ _	212	132M
31	30.76	1627	2.71	43141			
27	35.44	1880	2.35	44541			
26	37.06	1955	2.13	45717			
22	42.7	2265	1.84	47316			
20	47.93	2528	1.67	46245			
19	51.49	2714	1.43	46800			
17	57.75	3042	1.37	46437			
15	62.05	3259	1.28	46050			
16	60.23	3156	1.19	49200	M 1 0 3 1 5 6 . _ M _ _ _ _ 5 . 5 C _ _	239	132M
14	66.93	3508	1.07	49000			
13	71.17	3725	1.18	48900			
12	79.08	4139	1.07	44490			
27	35.52	1867	3.4	66700	M 1 3 2 1 3 6 . _ M _ _ _ _ 5 . 5 C _ _	272	132M
25	39.01	2041	3.16	66700			
22	43.45	2277	2.84	66600			
24	39.93	2094	2.84	66700	M 1 3 3 1 4 0 . _ M _ _ _ _ 5 . 5 C _ _	294	132M
22	44.18	2312	2.75	66600			
19	50.02	2606	2.44	66500			
17	56.93	2991	2.07	66637			
15	64.17	3376	1.84	66654			
13	71.32	3719	1.71	66491			
12	80.39	4192	1.51	66391			
11	90.75	4729	1.31	66193			
9.5	101.07	5262	1.18	66062			
8.4	113.69	5899	1.08	65479			
7.6	126.62	6564	0.97	65266			
6.9	139.07	7192	0.9	65100			
6.2	154.89	8002	0.81	64833			
16	59.46	3098	3.58	80900	M 1 4 3 1 5 6 . _ M _ _ _ _ 5 . 5 C _ _	423	132M
15	65.55	3429	3.24	80900			
12	78.7	4087	2.69	80900			
11	86.76	4514	2.44	80900			
10	94.35	4923	2.25	80900			
9.4	102.23	5308	2.09	80900			
7.7	124.89	6477	1.7	80900			
7.1	135.31	7026	1.57	80900			
6.7	142.66	7367	1.37	80900			
6.2	154.57	7992	1.26	80900			
5.2	185.56	9633	1.14	80900			
4.6	208.15	10784	1.02	80713			
4.5	211.96	10956	0.92	80700			

NOTE

Other output speeds are available using 2 and 8 pole motors - Consult Application Engineering

SERIES M

SELECTION TABLES

GEARED MOTORS

7.5 kW

4 POLE

N2 R/MIN	i	M2 Nm	Fm	N	Unit Designation	Kg	Motor Size
Output Speed	Ratio	Output Torque	Service Factor	Overhung Load	Column Entry [1] Through [20] Spaces to be filled when entering order	Weight	
393	3.68	175	1.74	7265	M 0 7 2 2 3 . 6 _ M _ _ _ _ 7 . 5 A _ _	92	132M
284	5.09	244	1.74	7470			
253	5.72	274	1.74	7415			
230	6.29	301	1.74	7310			
176	8.22	396	1.59	6860			
155	9.34	449	1.47	6545			
127	11.35	545	1.31	5134			
116	12.48	599	1.23	4621			
101	14.34	689	1.1	3952			
89	16.26	780	1.01	4148			
81	17.94	862	0.92	5440			
70	20.54	985	0.82	4570			
393	3.68	175	3.49	13458	M 0 8 2 2 3 . 6 _ M _ _ _ _ 7 . 5 A _ _	125	132M
277	5.21	250	3.49	13997			
249	5.79	278	3.49	14177			
224	6.44	311	3.37	14357			
173	8.33	402	2.91	14612			
155	9.35	450	2.71	14670			
126	11.47	550	2.38	14656			
112	12.92	618	2.17	14523			
96	15.04	726	1.95	14395			
87	16.69	797	1.78	13028			
79	18.26	874	1.55	12740			
70	20.66	989	1.47	12230			
62	23.32	1125	1.37	11635			
51	28.27	1352	1.18	10034			
44	32.97	1578	1.03	10100			
40	36.21	1731	0.95	8800			
113	12.74	615	3.93	22600	M 0 9 2 1 1 2 . _ M _ _ _ _ 7 . 5 A _ _	166	132M
99	14.53	702	3.6	23200			
87	16.59	801	3.27	23212			
78	18.43	886	2.98	23415			
70	20.59	990	2.86	24134			
63	22.87	1103	2.59	24702			
55	26.04	1249	2.11	25554			
50	28.74	1379	1.91	25813			
45	32.31	1558	1.49	26659			
41	35.67	1709	1.37	25925			
36	40.25	1932	1.28	27400			
33	44.44	2134	1.16	28800			
29	49.07	2350	1.03	28700			
56	26.03	1249	3.02	36300	M 1 0 2 1 2 5 . _ M _ _ _ _ 7 . 5 A _ _	212	132M
48	29.99	1440	2.62	37839			
47	30.76	1475	2.99	38185			
41	35.44	1702	2.59	39480			
39	37.06	1778	2.34	40372			
34	42.7	2046	2.03	42040			
30	47.93	2285	1.83	43318			
28	51.49	2468	1.57	44200			
25	57.75	2746	1.51	45700			
23	62.05	2953	1.41	46576			
24	60.23	2854	1.32	29100	M 1 0 3 1 5 6 . _ M _ _ _ _ 7 . 5 A _ _	239	132M
22	66.93	3170	1.19	29100			
20	71.17	3369	1.31	29100			
18	79.08	3741	1.18	45200			
15	95.44	4525	0.83	43700			
13	112.77	5335	0.83	42500			
41	35.52	1688	3.76	66500	M 1 3 2 1 3 6 . _ M _ _ _ _ 7 . 5 A _ _	272	132M
37	39.01	1855	3.48	66800			
33	43.45	2060	3.14	66700			
25	56.93	2692	2.3	66670	M 1 3 3 1 5 6 . _ M _ _ _ _ 7 . 5 A _ _	294	132M
23	64.17	3049	2.03	66779			
20	71.32	3365	1.89	66640			
18	80.39	3792	1.67	66637			
16	90.75	4280	1.45	66450			
14	101.07	4766	1.3	66300			
13	113.69	5339	1.19	65700			
11	126.62	5944	1.07	65400			
10	139.07	6508	0.99	65300			
9.3	154.89	7245	0.89	65100			
24	59.46	2812	3.73	66400	M 1 4 3 1 5 6 . _ M _ _ _ _ 7 . 5 A _ _	423	132M
22	65.55	3097	3.45	66400			
18	78.7	3712	2.96	66400			
17	86.76	4078	2.7	80900			
15	94.35	4443	2.5	80900			
14	102.23	4828	2.3	80900			
12	124.89	5871	1.87	80900			
11	135.31	6368	1.73	80900			
10	142.66	6667	1.51	80900			
9.3	154.57	7239	1.4	80900			
7.8	185.56	8723	1.26	80900			
6.9	208.15	9762	1.13	80900			
6.8	211.96	9923	1.02	80900			

NOTE
Other output speeds are available using 2 and 8 pole motors - Consult Application Engineering

SERIES M

SELECTION TABLES

GEARED MOTORS

7.5 kW

6 POLE

N2 R/MIN	i	M2 Nm	Fm	N	Unit Designation	Kg	Motor Size
Output Speed	Ratio	Output Torque	Service Factor	Overhung Load	Column Entry <input type="text" value="1"/> Through <input type="text" value="20"/> Spaces to be filled when entering order	Weight	
261	3.68	265	2.32	14100	M 0 8 2 2 3 . 6 _ M _ _ _ _ 7 . 5 C - -	159	160M
184	5.21	377	2.32	14850	5 . 0		
166	5.79	419	2.32	15100	5 . 6		
149	6.44	465	2.32	15100	6 . 3		
115	8.33	603	2.12	14600	8 . 0		
103	9.35	673	1.97	14250	9 . 0		
84	11.47	831	1.72	13480	1 1 .		
74	12.92	934	1.57	13155	1 2 .		
64	15.04	1086	1.43	11965	1 4 .		
58	16.69	1203	1.18	11344	1 6 .		
53	18.26	1317	1.03	9803	1 8 .		
46	20.66	1491	0.98	8297	2 0 .		
41	23.32	1688	0.91	7954	2 2 .		
34	28.27	2038	0.81	7954	2 8 .		
117	8.22	597	3.95	22500	M 0 9 2 1 8 . 0 _ M _ _ _ _ 7 . 5 C - -	200	160M
104	9.19	668	3.67	23000	9 . 0		
94	10.27	747	3.39	23300	1 0 .		
82	11.71	849	3.11	22983	1 1 .		
75	12.74	925	2.96	23358	1 2 .		
66	14.53	1056	2.71	24062	1 4 .		
58	16.59	1207	2.19	24105	1 6 .		
52	18.43	1337	1.97	24368	1 8 .		
47	20.59	1500	1.91	25190	2 0 .		
42	22.87	1662	1.72	25117	2 2 .		
37	26.04	1885	1.4	24662	2 5 .		
33	28.74	2082	1.27	23987	2 8 .		
30	32.31	2338	1.14	23875	3 2 .		
27	35.67	2583	1.04	22912	3 6 .		
24	40.25	2908	0.85	24802	4 0 .		
58	16.43	1193	3.16	35800	M 1 0 2 1 1 6 . _ M _ _ _ _ 7 . 5 C - -	246	160M
53	18.25	1321	2.85	36900	1 8 .		
49	19.41	1407	3.13	37700	2 0 .		
45	21.57	1560	2.83	38800	2 2 .		
37	26.03	1885	2	40900	2 5 .		
32	29.99	2175	1.73	40566	2 8 .		
31	30.76	2219	1.99	41063	3 2 .		
27	35.44	2563	1.72	41797	3 6 .		
26	37.06	2666	1.56	43606	4 0 .		
22	42.7	3089	1.35	45650	4 5 .		
20	47.93	3447	1.22	43962	5 0 .		
19	51.49	3702	1.05	45163	5 6 .		
17	57.75	4148	1	44642	6 3 .		
15	62.05	4444	0.94	44140	7 1 .		
16	60.23	4303	0.88	49200	M 1 0 3 1 5 6 . _ M _ _ _ _ 7 . 5 C - -	272	160M
13	71.17	5080	0.87	48900	7 1 .		
38	25.45	1830	3.39	66800	M 1 3 2 1 2 5 . _ M _ _ _ _ 7 . 5 C - -	307	160M
34	28.35	2039	3.04	66700	2 8 .		
30	31.89	2289	2.77	66600	3 2 .		
27	35.52	2546	2.49	65973	3 6 .		
25	39.01	2784	2.32	65712	4 0 .		
22	43.45	3105	2.08	66345	4 5 .		
24	39.93	2855	2.08	66700	M 1 3 3 1 4 0 . _ M _ _ _ _ 7 . 5 C - -	329	160M
22	44.18	3153	2.01	66600	4 5 .		
19	50.02	3554	1.79	66500	5 0 .		
17	56.93	4078	1.52	66555	5 6 .		
15	64.17	4603	1.35	66538	6 3 .		
13	71.32	5071	1.25	66325	7 1 .		
12	80.39	5717	1.11	66225	8 0 .		
11	90.75	6449	0.96	65868	9 0 .		
9.5	101.07	7175	0.86	65712	1 0 0		
24	39.42	2815	3.59	80900	M 1 4 2 1 4 0 . _ M _ _ _ _ 7 . 5 C - -	415	160M
22	42.71	3054	3.31	80900	4 5 .		
23	41.36	2960	3.55	66400	M 1 4 3 1 4 0 . _ M _ _ _ _ 7 . 5 C - -	460	160M
20	48.21	3423	3.21	66400	4 5 .		
18	54.75	3891	2.83	66400	5 0 .		
16	59.46	4225	2.63	80900	5 6 .		
15	65.55	4676	2.37	80900	6 3 .		
12	78.7	5574	1.97	80900	7 1 .		
11	86.76	6156	1.79	80900	8 0 .		
10	94.35	6713	1.65	80900	9 0 .		
9.4	102.23	7239	1.53	80900	1 0 0		
7.7	124.89	8832	1.25	80900	1 1 2		
7.1	135.31	9581	1.15	80900	1 2 5		
6.7	142.66	10046	1.01	80900	1 4 0		
6.2	154.57	10899	0.93	80900	1 6 0		
5.2	185.56	13136	0.84	80900	1 8 0		

NOTE

Other output speeds are available using 2 and 8 pole motors - Consult Application Engineering

SERIES M

SELECTION TABLES

GEARED MOTORS

11.0 kW

4 POLE

N2 R/MIN	i	M2 Nm	Fm	N	Unit Designation	Kg	Motor Size
Output Speed	Ratio	Output Torque	Service Factor	Overhung Load	Column Entry <input type="text" value="1"/> Through <input type="text" value="20"/> Spaces to be filled when entering order	Weight	
392	3.68	258	1.18	7040	M 0 7 2 2 3 . 6 _ M _ _ _ _ 1 1 . A - -	128	160M
283	5.09	359	1.18	7160	5 . 0		
252	5.72	403	1.18	6900	5 . 6		
229	6.29	443	1.18	6570	6 . 3		
175	8.22	584	1.08	5350	8 . 0		
154	9.34	661	1	4580	9 . 0		
394	3.68	257	2.39	13197	M 0 8 2 2 3 . 6 _ M _ _ _ _ 1 1 . A - -	159	160M
278	5.21	365	2.39	13625	5 . 0		
250	5.79	406	2.39	13768	5 . 6		
225	6.44	454	2.31	13910	6 . 3		
174	8.33	587	1.99	13346	8 . 0		
155	9.35	657	1.85	12957	9 . 0		
126	11.47	805	1.63	11998	1 1 .		
112	12.92	904	1.48	11250	1 2 .		
96	15.04	1062	1.34	10151	1 4 .		
87	16.69	1165	1.22	8656	1 6 .		
79	18.26	1278	1.06	8493	1 8 .		
70	20.66	1446	1.01	7120	2 0 .		
62	23.32	1644	0.94	5517	2 2 .		
51	28.27	1976	0.8	2284	2 8 .		
196	7.4	522	3.83	20209	M 0 9 2 1 7 . 1 _ M _ _ _ _ 1 1 . A - -	200	160M
176	8.22	579	3.59	20624	8 . 0		
158	9.19	648	3.35	21072	9 . 0		
141	10.27	726	3.08	20720	1 0 .		
124	11.71	827	2.83	21211	1 1 .		
114	12.74	899	2.69	21464	1 2 .		
100	14.53	1026	2.46	21675	1 4 .		
87	16.59	1171	2.24	21760	1 6 .		
79	18.43	1296	2.04	21601	1 8 .		
70	20.59	1447	1.95	22170	2 0 .		
63	22.87	1613	1.77	22312	2 2 .		
56	26.04	1826	1.45	23709	2 5 .		
50	28.74	2016	1.31	23427	2 8 .		
45	32.31	2278	1.02	24018	3 2 .		
41	35.67	2499	0.94	23066	3 6 .		
36	40.25	2824	0.87	25688	4 0 .		
88	16.43	1155	3.26	32215	M 1 0 2 1 1 6 . _ M _ _ _ _ 1 1 . A - -	246	160M
79	18.25	1283	2.94	32896	1 8 .		
75	19.41	1362	3.24	33324	2 0 .		
67	21.57	1515	2.91	32667	2 2 .		
56	26.03	1826	2.06	35310	2 5 .		
48	29.99	2105	1.79	36623	2 8 .		
47	30.76	2156	2.05	37054	3 2 .		
41	35.44	2487	1.77	37602	3 6 .		
39	37.06	2600	1.6	39044	4 0 .		
34	42.7	2990	1.39	40481	4 5 .		
30	47.93	3339	1.25	41536	5 0 .		
28	51.49	3607	1.07	42333	5 6 .		
25	57.75	4014	1.04	43600	6 3 .		
23	62.05	4316	0.96	44339	7 1 .		
24	60.23	4172	0.9	28788	M 1 0 3 1 5 6 . _ M _ _ _ _ 1 1 . A - -	272	160M
22	66.93	4633	0.81	28788	6 3 .		
20	71.17	4924	0.9	28788	7 1 .		
57	25.45	1780	3.48	60039	M 1 3 2 1 2 5 . _ M _ _ _ _ 1 1 . A - -	307	160M
51	28.35	1982	3.13	61744	2 8 .		
45	31.89	2224	2.85	63271	3 2 .		
41	35.52	2468	2.57	65208	3 6 .		
37	39.01	2712	2.38	65228	4 0 .		
33	43.45	3011	2.15	66000	4 5 .		
36	39.93	2777	1.99	50560	M 1 3 3 1 4 0 . _ M _ _ _ _ 1 1 . A - -	329	160M
33	44.18	3057	2.02	50560	4 5 .		
29	50.02	3453	1.83	50560	5 0 .		
25	56.93	3935	1.57	66616	5 6 .		
23	64.17	4457	1.39	66658	6 3 .		
20	71.32	4919	1.29	66481	7 1 .		
18	80.39	5543	1.15	66433	8 0 .		
16	90.75	6256	0.99	66100	9 0 .		
14	101.07	6966	0.89	65988	1 0 0 .		
37	39.42	2740	3.63	80924	M 1 4 2 1 4 0 . _ M _ _ _ _ 1 1 . A - -	415	160M
34	42.71	2964	3.37	80900	4 5 .		
35	41.36	2857	3.41	66432	M 1 4 3 1 4 0 . _ M _ _ _ _ 1 1 . A - -	460	160M
30	48.21	3324	3.31	66432	4 5 .		
26	54.75	3769	2.92	66432	5 0 .		
24	59.46	4110	2.55	66275	5 6 .		
22	65.55	4526	2.36	66275	6 3 .		
18	78.7	5426	2.03	66206	7 1 .		
17	86.76	5960	1.85	80900	8 0 .		
15	94.35	6494	1.71	80900	9 0 .		
14	102.23	7057	1.57	80900	1 0 0 .		
12	124.89	8581	1.28	80900	1 1 2 .		
11	135.31	9307	1.18	80900	1 2 5 .		
10	142.66	9745	1.04	80900	1 4 0 .		
9.4	154.57	10580	0.95	80900	1 6 0 .		

NOTE
Other output speeds are available using 2 and 8 pole motors - Consult Application Engineering

SERIES M

SELECTION TABLES

GEARED MOTORS

11.0 kW

6 POLE

N2 R/MIN	i	M2 Nm	Fm	N	Unit Designation	Kg	Motor Size
Output Speed	Ratio	Output Torque	Service Factor	Overhung Load	Column Entry 1 Through 20 Spaces to be filled when entering order	Weight	
262	3.68	388	1.59	13700	M 0 8 2 2 3 . 6 _ M _ _ _ _ 1 1 . C - -	173	160L
185	5.21	550	1.59	14300	5 . 0		
167	5.79	611	1.59	14500	5 . 6		
150	6.44	679	1.59	14200	6 . 3		
116	8.33	880	1.45	12500	8 . 0		
103	9.35	983	1.35	11500	9 . 0		
84	11.47	1213	1.18	9460	1 1 .		
75	12.92	1363	1.08	8210	1 2 .		
64	15.04	1585	0.98	6260	1 4 .		
58	16.69	1755	0.81	4690	1 6 .		
262	3.69	394	2.76	19200	M 0 9 2 1 3 . 6 _ M _ _ _ _ 1 1 . C - -	214	160L
211	4.58	488	3.89	20000	4 . 5		
190	5.07	538	3.67	20400	5 . 0		
170	5.69	602	3.42	20800	5 . 6		
146	6.63	702	3.09	21200	6 . 3		
130	7.4	785	2.88	21135	7 . 1		
117	8.22	872	2.7	21442	8 . 0		
105	9.19	974	2.51	21615	9 . 0		
94	10.27	1089	2.32	21371	1 0 .		
82	11.71	1239	2.13	20678	1 1 .		
76	12.74	1350	2.03	21011	1 2 .		
66	14.53	1541	1.86	21196	1 4 .		
58	16.59	1761	1.5	21111	1 6 .		
52	18.43	1951	1.35	20837	1 8 .		
47	20.59	2188	1.31	21381	2 0 .		
42	22.87	2426	1.18	20734	2 2 .		
37	26.04	2751	0.96	20900	2 5 .		
34	28.74	3037	0.87	19700	2 8 .		
91	10.59	1121	3.36	32000	M 1 0 2 1 1 0 . _ M _ _ _ _ 1 1 . C - -	260	160L
81	11.98	1269	2.97	32600	1 1 .		
77	12.51	1322	3.33	32900	1 2 .		
68	14.16	1498	2.94	33600	1 4 .		
59	16.43	1740	2.17	33980	1 6 .		
53	18.25	1927	1.96	34597	1 8 .		
50	19.41	2053	2.15	35273	2 0 .		
45	21.57	2276	1.94	35797	2 2 .		
37	26.03	2750	1.37	37882	2 5 .		
32	29.99	3173	1.19	36833	2 8 .		
31	30.76	3238	1.36	37427	3 2 .		
27	35.44	3740	1.18	36994	3 6 .		
26	37.06	3890	1.07	39913	4 0 .		
23	42.7	4507	0.92	42733	4 5 .		
20	47.93	5030	0.84	39966	5 0 .		
54	18	1900	3.26	60900	M 1 3 2 1 1 8 . _ M _ _ _ _ 1 1 . C - -	321	160L
48	20	2105	3.02	62800	2 0 .		
43	22.55	2371	2.68	64800	2 2 .		
38	25.45	2671	2.32	64812	2 5 .		
34	28.35	2975	2.08	64896	2 8 .		
30	31.89	3340	1.9	64772	3 2 .		
27	35.52	3715	1.71	64702	3 6 .		
25	39.01	4062	1.59	63983	4 0 .		
22	43.45	4531	1.43	65900	4 5 .		
24	39.93	4166	1.43	66700	M 1 3 3 1 4 0 . _ M _ _ _ _ 1 1 . C - -	343	160L
22	44.18	4601	1.38	66600	4 5 .		
19	50.02	5185	1.22	66500	5 0 .		
17	56.93	5951	1.04	66410	5 6 .		
15	64.17	6717	0.92	66335	6 3 .		
14	71.32	7400	0.86	66033	7 1 .		
34	28.25	2967	3.36	80900	M 1 4 2 1 2 8 . _ M _ _ _ _ 1 1 . C - -	429	160L
28	34.51	3625	2.95	80900	3 2 .		
26	37.39	3913	2.76	80900	3 6 .		
24	39.42	4108	2.46	80853	4 0 .		
23	42.71	4456	2.27	80864	4 5 .		
23	41.36	4319	2.43	66135	M 1 4 3 1 4 0 . _ M _ _ _ _ 1 1 . C - -	474	160L
20	48.21	4994	2.2	66135	4 5 .		
18	54.75	5677	1.94	66135	5 0 .		
16	59.46	6165	1.8	80900	5 6 .		
15	65.55	6824	1.63	80900	6 3 .		
12	78.7	8133	1.35	80900	7 1 .		
11	86.76	8983	1.22	80900	8 0 .		
10	94.35	9795	1.13	80900	9 0 .		
9.4	102.23	10562	1.05	80900	1 0 0		
7.7	124.89	12887	0.85	80900	1 1 2		

NOTE

Other output speeds are available using 2 and 8 pole motors - Consult Application Engineering

SERIES M

SELECTION TABLES

GEARED MOTORS

15.0 kW

4 POLE

N2 R/MIN	i	M2 Nm	Fm	N	Unit Designation	Kg	Motor Size
Output Speed	Ratio	Output Torque	Service Factor	Overhung Load	Column Entry [1] Through [20] Spaces to be filled when entering order	Weight	
396	3.68	349	1.76	12900	M 0 8 2 2 3 . 6 _ M _ _ _ _ 1 5 . A - -	173	160L
279	5.21	496	1.76	13200	5 . 0		
251	5.79	552	1.76	13300	5 . 6		
226	6.44	617	1.7	13400	6 . 3		
175	8.33	798	1.47	11900	8 . 0		
156	9.35	893	1.36	11000	9 . 0		
127	11.47	1093	1.2	8959	1 1 .		
113	12.92	1228	1.09	7509	1 2 .		
97	15.04	1444	0.98	5299	1 4 .		
87	16.69	1584	0.9	3659	1 6 .		
441	3.3	319	3.41	17400	M 0 9 2 1 3 . 2 _ M _ _ _ _ 1 5 . A - -	214	160L
394	3.69	356	3.06	18000	3 . 6		
318	4.58	440	3.81	18700	4 . 5		
287	5.07	487	3.59	18900	5 . 0		
256	5.69	544	3.34	19200	5 . 6		
220	6.63	636	3.02	19500	6 . 3		
197	7.4	710	2.82	19772	7 . 1		
177	8.22	787	2.64	20127	8 . 0		
158	9.19	881	2.46	20381	9 . 0		
142	10.27	987	2.27	19486	1 0 .		
124	11.71	1124	2.08	19966	1 1 .		
114	12.74	1222	1.98	20166	1 2 .		
100	14.53	1395	1.81	19933	1 4 .		
88	16.59	1592	1.65	20102	1 6 .		
79	18.43	1761	1.5	19528	1 8 .		
71	20.59	1967	1.44	19926	2 0 .		
64	22.87	2192	1.3	19580	2 2 .		
56	26.04	2482	1.06	21600	2 5 .		
51	28.74	2740	0.96	20700	2 8 .		
137	10.59	1014	3.63	29400	M 1 0 2 1 1 0 . _ M _ _ _ _ 1 5 . A - -	260	160L
121	11.98	1147	3.28	30000	1 1 .		
116	12.51	1196	3.25	30200	1 2 .		
103	14.16	1351	3	30954	1 4 .		
89	16.43	1569	2.4	31354	1 6 .		
80	18.25	1744	2.16	31312	1 8 .		
75	19.41	1851	2.38	31628	2 0 .		
67	21.57	2060	2.14	30688	2 2 .		
56	26.03	2482	1.52	34179	2 5 .		
49	29.99	2860	1.32	35232	2 8 .		
47	30.76	2929	1.51	35762	3 2 .		
41	35.44	3380	1.3	35456	3 6 .		
39	37.06	3533	1.18	37527	4 0 .		
34	42.7	4064	1.02	38700	4 5 .		
30	47.93	4538	0.92	39500	5 0 .		
81	18	1719	3.61	55200	M 1 3 2 1 1 8 . _ M _ _ _ _ 1 5 . A - -	321	160L
73	20	1902	3.34	56100	2 0 .		
65	22.55	2142	2.96	56772	2 2 .		
57	25.45	2419	2.56	58681	2 5 .		
51	28.35	2694	2.3	60368	2 8 .		
46	31.89	3023	2.1	61752	3 2 .		
41	35.52	3354	1.89	63733	3 6 .		
37	39.01	3685	1.75	63433	4 0 .		
33	43.45	4091	1.58	65200	4 5 .		
36	39.93	3774	1.47	49920	M 1 3 3 1 4 0 . _ M _ _ _ _ 1 5 . A - -	343	160L
33	44.18	4154	1.49	49920	4 5 .		
29	50.02	4692	1.34	49920	5 0 .		
26	56.93	5348	1.16	66554	5 6 .		
23	64.17	6057	1.02	66520	6 3 .		
20	71.32	6684	0.95	66300	7 1 .		
18	80.39	7533	0.84	66200	8 0 .		
52	28.25	2680	3.72	79400	M 1 4 2 1 2 8 . _ M _ _ _ _ 1 5 . A - -	429	160L
42	34.51	3277	3.26	80900	3 2 .		
39	37.39	3540	3.05	80900	3 6 .		
37	39.42	3724	2.67	80827	4 0 .		
34	42.71	4029	2.48	80900	4 5 .		
35	41.36	3882	2.51	66304	M 1 4 3 1 4 0 . _ M _ _ _ _ 1 5 . A - -	474	160L
30	48.21	4517	2.44	66304	4 5 .		
27	54.75	5122	2.15	66304	5 0 .		
24	59.46	5585	1.88	66133	5 6 .		
22	65.55	6151	1.74	66133	6 3 .		
18	78.7	7373	1.49	65986	7 1 .		
17	86.76	8100	1.36	80900	8 0 .		
15	94.35	8825	1.26	80900	9 0 .		
14	102.23	9591	1.16	80900	1 0 0		
12	124.89	11661	0.94	80900	1 1 2		
11	135.31	12648	0.87	80900	1 2 5		

NOTE
Other output speeds are available using 2 and 8 pole motors - Consult Application Engineering

SERIES M

SELECTION TABLES

GEARED MOTORS

15.0 kW

6 POLE

N2 R/MIN	i	M2 Nm	Fm	N	Unit Designation	Kg	Motor Size
Output Speed	Ratio	Output Torque	Service Factor	Overhung Load	Column Entry <input type="text" value="1"/> Through <input type="text" value="20"/> Spaces to be filled when entering order	Weight	
656	1.48	213	3.49	15400	M 0 9 2 1 1 . 4 _ M _ _ _ _ 1 5 . C - -	313	180L
476	2.04	295	3.49	17100	1 . 8		
425	2.28	331	3.29	17700	2 . 2		
379	2.56	371	2.93	18200	2 . 5		
327	2.97	427	3.49	18600	2 . 8		
294	3.3	478	2.28	18700	3 . 2		
263	3.69	535	2.03	18884	3 . 6		
237	4.09	587	3.08	19305	4 . 0		
212	4.58	662	2.87	19663	4 . 5		
191	5.07	731	2.71	20042	5 . 0		
171	5.69	817	2.52	20400	5 . 6		
146	6.63	953	2.28	20336	6 . 3		
131	7.4	1065	2.12	20033	7 . 1		
118	8.22	1183	1.99	20233	8 . 0		
106	9.19	1322	1.85	20033	9 . 0		
94	10.27	1478	1.71	19166	1 0 .		
83	11.71	1682	1.57	18045	1 1 .		
76	12.74	1832	1.5	18329	1 2 .		
67	14.53	2091	1.37	17921	1 4 .		
58	16.59	2389	1.1	17688	1 6 .		
53	18.43	2648	1	16802	1 8 .		
47	20.59	2969	0.96	17028	2 0 .		
42	22.87	3291	0.87	15725	2 2 .		
443	2.19	315	3.49	23700	M 1 0 2 1 2 . 2 _ M _ _ _ _ 1 5 . C - -	359	180L
390	2.49	358	3.49	24700	2 . 5		
324	2.99	429	3.49	26000	2 . 8		
299	3.24	468	3.35	26100	3 . 2		
277	3.5	505	3.11	26300	3 . 6		
232	4.18	598	3.49	27100	4 . 0		
213	4.55	653	3.49	27300	4 . 5		
196	4.94	707	3.49	27700	5 . 0		
181	5.37	770	3.49	28100	5 . 6		
144	6.72	965	3.49	29200	6 . 3		
134	7.26	1043	3.49	29500	7 . 1		
122	7.95	1139	3.3	30000	8 . 0		
113	8.58	1230	3.15	30400	9 . 0		
92	10.59	1520	2.48	31305	1 0 .		
81	11.98	1722	2.19	31821	1 1 .		
78	12.51	1794	2.45	32100	1 2 .		
68	14.16	2033	2.17	32315	1 4 .		
59	16.43	2361	1.6	31900	1 6 .		
53	18.25	2615	1.44	31966	1 8 .		
50	19.41	2785	1.58	32500	2 0 .		
45	21.57	3088	1.43	32366	2 2 .		
37	26.03	3731	1.01	34434	2 5 .		
32	29.99	4305	0.88	32566	2 8 .		
32	30.76	4393	1	33272	3 2 .		
27	35.44	5075	0.87	31505	3 6 .		
78	12.39	1771	3.58	55600	M 1 3 2 1 1 2 . _ M _ _ _ _ 1 5 . C - -	419	180L
69	14.03	2008	3.13	56600	1 4 .		
61	15.97	2289	2.71	58200	1 6 .		
54	18	2578	2.4	59209	1 8 .		
48	20	2856	2.22	60900	2 0 .		
43	22.55	3217	1.97	62554	2 2 .		
38	25.45	3623	1.71	62540	2 5 .		
34	28.35	4036	1.54	62835	2 8 .		
30	31.89	4532	1.4	62684	3 2 .		
27	35.52	5041	1.26	63248	3 6 .		
25	39.01	5511	1.17	62008	4 0 .		
22	43.45	6147	1.05	65390	4 5 .		
24	39.93	5652	1.05	66700	M 1 3 3 1 4 0 . _ M _ _ _ _ 1 5 . C - -	441	180L
22	44.18	6242	1.02	66600	4 5 .		
19	50.02	7034	0.9	66500	5 0 .		
40	23.97	3425	3.15	80900	M 1 4 2 1 2 2 . _ M _ _ _ _ 1 5 . C - -	529	180L
37	26.07	3728	2.84	80900	2 5 .		
34	28.25	4025	2.48	79745	2 8 .		
28	34.51	4917	2.18	79109	3 2 .		
26	37.39	5308	2.03	78890	3 6 .		
25	39.42	5573	1.81	80800	4 0 .		
23	42.71	6045	1.67	80823	4 5 .		
23	41.36	5860	1.79	65833	M 1 4 3 1 4 0 . _ M _ _ _ _ 1 5 . C - -	574	180L
20	48.21	6775	1.62	65833	4 5 .		
18	54.75	7702	1.43	65833	5 0 .		
16	59.46	8364	1.33	80900	5 6 .		
15	65.55	9257	1.2	80900	6 3 .		
12	78.7	11033	1	80900	7 1 .		
11	86.76	12186	0.9	80900	8 0 .		
10	94.35	13288	0.84	80900	9 0 .		

NOTE
Other output speeds are available using 2 and 8 pole motors - Consult Application Engineering

SERIES M

SELECTION TABLES

GEARED MOTORS

18.5 kW

4 POLE

N2 R/MIN	i	M2 Nm	Fm	N	Unit Designation	Kg	Motor Size
Output Speed	Ratio	Output Torque	Service Factor	Overhung Load	Column Entry [1] Through [20] Spaces to be filled when entering order	Weight	
574	2.56	299	3.6	16006	M 0 9 2 1 2 . 5 _ M _ _ _ _ 1 8 . A - -	299	180M
445	3.3	390	2.79	17283	3 . 2		
399	3.69	435	2.5	17871	3 . 6		
360	4.09	477	3.35	18271	4 . 0		
321	4.58	537	3.12	18560	4 . 5		
290	5.07	594	2.94	18760	5 . 0		
259	5.69	664	2.74	19025	5 . 6		
222	6.63	776	2.47	19255	6 . 3		
199	7.4	866	2.31	19390	7 . 1		
179	8.22	960	2.16	19692	8 . 0		
160	9.19	1076	2.02	19777	9 . 0		
143	10.27	1205	1.86	18406	1 0 .		
126	11.71	1373	1.7	18877	1 1 .		
115	12.74	1491	1.62	19031	1 2 .		
101	14.53	1703	1.49	18408	1 4 .		
89	16.59	1943	1.35	18651	1 6 .		
80	18.43	2150	1.23	17714	1 8 .		
71	20.59	2401	1.18	17963	2 0 .		
64	22.87	2676	1.07	17190	2 2 .		
202	7.26	847	3.8	27300	M 1 0 2 1 7 . 1 _ M _ _ _ _ 1 8 . A - -	345	180M
185	7.95	927	3.59	27700	8 . 0		
171	8.58	1000	3.42	28166	9 . 0		
139	10.59	1238	2.97	29096	1 0 .		
123	11.98	1401	2.69	29661	1 1 .		
118	12.51	1460	2.66	29861	1 2 .		
104	14.16	1649	2.46	30551	1 4 .		
89	16.43	1916	1.97	30601	1 6 .		
81	18.25	2129	1.77	29926	1 8 .		
76	19.41	2260	1.95	30144	2 0 .		
68	21.57	2514	1.75	28955	2 2 .		
56	26.03	3030	1.24	33189	2 5 .		
49	29.99	3492	1.08	34016	2 8 .		
48	30.76	3576	1.23	34631	3 2 .		
41	35.44	4126	1.07	33578	3 6 .		
40	37.06	4313	0.96	36200	4 0 .		
105	14.03	1632	3.85	52700	M 1 3 2 1 1 4 . _ M _ _ _ _ 1 8 . A - -	405	180M
92	15.97	1860	3.33	53508	1 6 .		
82	18	2099	2.95	54351	1 8 .		
73	20	2322	2.73	55137	2 0 .		
65	22.55	2615	2.43	55689	2 2 .		
58	25.45	2954	2.1	57493	2 5 .		
52	28.35	3288	1.89	59164	2 8 .		
46	31.89	3690	1.72	60423	3 2 .		
41	35.52	4094	1.55	62442	3 6 .		
38	39.01	4499	1.44	61862	4 0 .		
34	43.45	4995	1.29	64500	4 5 .		
37	39.93	4607	1.2	49360	M 1 3 3 1 4 0 . _ M _ _ _ _ 1 8 . A - -	427	180M
33	44.18	5071	1.22	49360	4 5 .		
29	50.02	5728	1.1	49360	5 0 .		
26	56.93	6529	0.95	66500	5 6 .		
23	64.17	7394	0.84	66400	6 3 .		
61	23.97	2787	3.87	75200	M 1 4 2 1 2 2 . _ M _ _ _ _ 1 8 . A - -	515	180M
56	26.07	3003	3.5	77000	2 5 .		
52	28.25	3272	3.05	78603	2 8 .		
43	34.51	4001	2.67	79736	3 2 .		
39	37.39	4321	2.5	79675	3 6 .		
37	39.42	4546	2.19	80742	4 0 .		
34	42.71	4918	2.03	80900	4 5 .		
36	41.36	4739	2.05	66192	M 1 4 3 1 4 0 . _ M _ _ _ _ 1 8 . A - -	560	180M
30	48.21	5514	1.99	66192	4 5 .		
27	54.75	6253	1.76	66192	5 0 .		
25	59.46	6818	1.54	66008	5 6 .		
22	65.55	7509	1.42	66008	6 3 .		
19	78.7	9001	1.22	65793	7 1 .		
17	86.76	9888	1.11	80900	8 0 .		
16	94.35	10774	1.03	80900	9 0 .		
14	102.23	11708	0.95	80900	1 0 0		

NOTE
Other output speeds are available using 2 and 8 pole motors - Consult Application Engineering

SERIES M

SELECTION TABLES

GEARED MOTORS

18.5 kW

6 POLE

N2 R/MIN	i	M2 Nm	Fm	N	Unit Designation	Kg	Motor Size
Output Speed	Ratio	Output Torque	Service Factor	Overhung Load	Column Entry 1 Through 20 Spaces to be filled when entering order	Weight	
659	1.48	261	2.84	15306	M 0 9 2 1 1 . 4 _ M _ _ _ _ 1 8 . C - -	368	200L
479	2.04	362	2.84	16936	1 . 8		
427	2.28	406	2.68	17513	2 . 2		
381	2.56	456	2.39	18013	2 . 5		
328	2.97	523	2.84	18413	2 . 8		
295	3.3	587	1.86	18443	3 . 2		
264	3.69	657	1.66	18607	3 . 6		
239	4.09	721	2.51	19047	4 . 0		
213	4.58	812	2.34	19368	4 . 5		
192	5.07	897	2.21	19728	5 . 0		
171	5.69	1003	2.05	20050	5 . 6		
147	6.63	1169	1.86	19581	6 . 3		
132	7.4	1306	1.73	19068	7 . 1		
119	8.22	1452	1.62	19175	8 . 0		
106	9.19	1622	1.51	18648	9 . 0		
95	10.27	1814	1.39	17237	1 0 .		
83	11.71	2063	1.28	15741	1 1 .		
77	12.74	2248	1.22	15982	1 2 .		
67	14.53	2566	1.11	15055	1 4 .		
59	16.59	2932	0.9	14694	1 6 .		
53	18.43	3249	0.81	13271	1 8 .		
676	1.44	253	2.84	20700	M 1 0 2 1 1 . 4 _ M _ _ _ _ 1 8 . C - -	414	200L
484	2.01	355	2.84	23000	1 . 8		
445	2.19	386	2.84	23560	2 . 2		
392	2.49	439	2.84	24536	2 . 5		
326	2.99	527	2.84	25813	2 . 8		
301	3.24	574	2.73	25866	3 . 2		
279	3.5	620	2.53	26066	3 . 6		
233	4.18	734	2.84	26843	4 . 0		
215	4.55	801	2.84	27043	4 . 5		
197	4.94	868	2.84	27420	5 . 0		
182	5.37	945	2.84	27796	5 . 6		
145	6.72	1185	2.84	28803	6 . 3		
134	7.26	1280	2.84	29080	7 . 1		
123	7.95	1397	2.69	29556	8 . 0		
114	8.58	1509	2.56	29910	9 . 0		
92	10.59	1866	2.02	30697	1 0 .		
81	11.98	2112	1.78	31139	1 1 .		
78	12.51	2201	2	31400	1 2 .		
69	14.16	2494	1.77	31192	1 4 .		
59	16.43	2897	1.3	30080	1 6 .		
53	18.25	3208	1.17	29664	1 8 .		
50	19.41	3418	1.29	30073	2 0 .		
45	21.57	3789	1.16	29364	2 2 .		
37	26.03	4578	0.82	31417	2 5 .		
32	30.76	5391	0.82	29636	3 2 .		
336	2.9	510	3.41	44500	M 1 3 2 1 2 . 8 _ M _ _ _ _ 1 8 . C - -	475	200L
306	3.19	560	3.41	45000	3 . 2		
268	3.64	639	3.41	45700	3 . 6		
242	4.03	709	3.41	46300	4 . 0		
221	4.42	780	3.41	46800	4 . 5		
193	5.04	885	3.41	47600	5 . 0		
176	5.54	973	3.41	48400	5 . 6		
157	6.21	1094	3.41	49300	6 . 3		
142	6.88	1214	3.41	50100	7 . 1		
125	7.78	1366	3.41	51200	8 . 0		
113	8.62	1513	3.41	52000	9 . 0		
99	9.89	1742	3.41	53100	1 0 .		
87	11.2	1978	3	54200	1 1 .		
79	12.39	2174	2.92	54733	1 2 .		
69	14.03	2463	2.55	55550	1 4 .		
61	15.97	2809	2.21	56896	1 6 .		
54	18	3163	1.96	57729	1 8 .		
49	20	3505	1.81	59237	2 0 .		
43	22.55	3947	1.61	60589	2 2 .		
38	25.45	4446	1.39	60552	2 5 .		
34	28.35	4953	1.25	61032	2 8 .		
31	31.89	5560	1.14	60857	3 2 .		
27	35.52	6185	1.03	61977	3 6 .		
25	39.01	6762	0.96	60279	4 0 .		
22	43.45	7543	0.86	64945	4 5 .		
24	39.93	6935	0.86	66700	M 1 3 3 1 4 0 . _ M _ _ _ _ 1 8 . C - -	497	200L
22	44.18	7660	0.83	66600	4 5 .		
54	18.11	3174	3.5	78000	M 1 4 2 1 1 8 . _ M _ _ _ _ 1 8 . C - -	586	200L
45	21.75	3808	2.78	80900	2 0 .		
41	23.97	4203	2.57	79692	2 2 .		
37	26.07	4575	2.32	79867	2 5 .		
35	28.25	4939	2.02	78735	2 8 .		
28	34.51	6034	1.77	77542	3 2 .		
26	37.39	6514	1.66	77132	3 6 .		
25	39.42	6839	1.48	80753	4 0 .		
23	42.71	7418	1.36	80788	4 5 .		
24	41.36	7190	1.46	65568	M 1 4 3 1 4 0 . _ M _ _ _ _ 1 8 . C - -	631	200L
20	48.21	8314	1.32	65568	4 5 .		
18	54.75	9451	1.16	65568	5 0 .		
16	59.46	10263	1.08	80900	5 6 .		
15	65.55	11359	0.98	80900	6 3 .		
12	78.7	13538	0.81	80900	7 1 .		

NOTE

Other output speeds are available using 2 and 8 pole motors - Consult Application Engineering

SERIES M

SELECTION TABLES

GEARED MOTORS

22.0 kW

4 POLE

N2 R/MIN	i	M2 Nm	Fm	N	Unit Designation	Kg	Motor Size
Output Speed	Ratio	Output Torque	Service Factor	Overhung Load	Column Entry [1] Through [20] Spaces to be filled when entering order	Weight	
994	1.48	206	3.6	13447	M 0 9 2 1 1 . 4 _ M _ _ _ _ 2 2 . A - -	313	180L
722	2.04	284	3.5	14860	1 . 8		
644	2.28	318	3.39	15413	2 . 2		
574	2.56	356	3.03	15913	2 . 5		
495	2.97	412	3.4	16813	2 . 8		
445	3.3	463	2.35	17166	3 . 2		
399	3.69	517	2.11	17743	3 . 6		
360	4.09	568	2.82	18143	4 . 0		
321	4.58	639	2.63	18420	4 . 5		
290	5.07	707	2.47	18620	5 . 0		
259	5.69	789	2.3	18850	5 . 6		
222	6.63	923	2.08	19010	6 . 3		
199	7.4	1030	1.94	19009	7 . 1		
179	8.22	1142	1.82	19257	8 . 0		
160	9.19	1279	1.7	19172	9 . 0		
143	10.27	1433	1.56	17327	1 0 .		
126	11.71	1632	1.43	17788	1 1 .		
115	12.74	1774	1.36	17895	1 2 .		
101	14.53	2025	1.25	16884	1 4 .		
89	16.59	2311	1.13	17200	1 6 .		
80	18.43	2557	1.03	15899	1 8 .		
71	20.59	2856	0.99	15999	2 0 .		
64	22.87	3182	0.9	14800	2 2 .		
1019	1.44	200	3.6	18100	M 1 0 2 1 1 . 4 _ M _ _ _ _ 2 2 . A - -	359	180L
730	2.01	280	3.6	20100	1 . 8		
671	2.19	305	3.6	20600	2 . 2		
591	2.49	346	3.6	21400	2 . 5		
491	2.99	413	3.6	22800	2 . 8		
453	3.24	451	3.39	23300	3 . 2		
420	3.5	488	3.19	23800	3 . 6		
352	4.18	579	3.6	25300	4 . 0		
323	4.55	632	3.6	25600	4 . 5		
298	4.94	685	3.6	25900	5 . 0		
274	5.37	746	3.6	26200	5 . 6		
219	6.72	934	3.36	26800	6 . 3		
202	7.26	1008	3.19	27101	7 . 1		
185	7.95	1103	3.02	27501	8 . 0		
171	8.58	1189	2.88	27933	9 . 0		
139	10.59	1473	2.5	28793	1 0 .		
123	11.98	1666	2.26	29323	1 1 .		
118	12.51	1736	2.24	29523	1 2 .		
104	14.16	1961	2.06	30148	1 4 .		
89	16.43	2278	1.65	29848	1 6 .		
81	18.25	2532	1.49	28540	1 8 .		
76	19.41	2688	1.64	28660	2 0 .		
68	21.57	2990	1.47	27223	2 2 .		
56	26.03	3604	1.05	32200	2 5 .		
49	29.99	4152	0.91	32800	2 8 .		
48	30.76	4253	1.04	33500	3 2 .		
41	35.44	4907	0.9	31700	3 6 .		
131	11.2	1558	3.81	50400	M 1 3 2 1 1 1 . _ M _ _ _ _ 2 2 . A - -	419	180L
119	12.39	1716	3.7	51300	1 2 .		
105	14.03	1941	3.24	52018	1 4 .		
92	15.97	2212	2.8	52817	1 6 .		
82	18	2496	2.48	53502	1 8 .		
73	20	2761	2.3	54175	2 0 .		
65	22.55	3110	2.04	54606	2 2 .		
58	25.45	3512	1.76	56306	2 5 .		
52	28.35	3911	1.59	57960	2 8 .		
46	31.89	4388	1.45	59094	3 2 .		
41	35.52	4869	1.3	61151	3 6 .		
38	39.01	5350	1.21	60291	4 0 .		
34	43.45	5940	1.09	63800	4 5 .		
37	39.93	5479	1.01	48800	M 1 3 3 1 4 0 . _ M _ _ _ _ 2 2 . A - -	441	180L
33	44.18	6031	1.02	48800	4 5 .		
29	50.02	6812	0.93	48800	5 0 .		
68	21.75	2999	3.53	73600	M 1 4 2 1 2 0 . _ M _ _ _ _ 2 2 . A - -	529	180L
61	23.97	3314	3.26	74382	2 2 .		
56	26.07	3571	2.94	75965	2 5 .		
52	28.25	3891	2.56	77807	2 8 .		
43	34.51	4758	2.25	78572	3 2 .		
39	37.39	5139	2.1	78450	3 6 .		
37	39.42	5406	1.84	80657	4 0 .		
34	42.71	5849	1.71	80900	4 5 .		
36	41.36	5636	1.73	66080	M 1 4 3 1 4 0 . _ M _ _ _ _ 2 2 . A - -	574	180L
30	48.21	6557	1.68	66080	4 5 .		
27	54.75	7436	1.48	66080	5 0 .		
25	59.46	8108	1.29	65884	5 6 .		
22	65.55	8930	1.2	65884	6 3 .		
19	78.7	10704	1.03	65600	7 1 .		
17	86.76	11758	0.94	80900	8 0 .		
16	94.35	12812	0.87	80900	9 0 .		

NOTE
Other output speeds are available using 2 and 8 pole motors - Consult Application Engineering

SERIES M

SELECTION TABLES

GEARED MOTORS

22.0 kW

6 POLE

N2 R/MIN	i	M2 Nm	Fm	N	Unit Designation	Kg	Motor Size
Output Speed	Ratio	Output Torque	Service Factor	Overhung Load	Column Entry <input type="text" value="1"/> Through <input type="text" value="20"/> Spaces to be filled when entering order	Weight	
659	1.48	311	2.39	15213	M 0 9 2 1 1 . 4 _ M _ _ _ _ 2 2 . C - -	368	200L
479	2.04	430	2.39	16773	1 . 8		
427	2.28	483	2.25	17326	2 . 2		
381	2.56	542	2.01	17826	2 . 5		
328	2.97	623	2.39	18226	2 . 8		
295	3.3	698	1.56	18186	3 . 2		
264	3.69	781	1.39	18331	3 . 6		
239	4.09	857	2.11	18789	4 . 0		
213	4.58	966	1.97	19073	4 . 5		
192	5.07	1066	1.86	19415	5 . 0		
171	5.69	1193	1.73	19700	5 . 6		
147	6.63	1390	1.56	18826	6 . 3		
132	7.4	1554	1.45	18104	7 . 1		
119	8.22	1727	1.37	18117	8 . 0		
106	9.19	1929	1.27	17264	9 . 0		
95	10.27	2157	1.17	15308	1 0 .		
83	11.71	2454	1.08	13436	1 1 .		
77	12.74	2673	1.02	13634	1 2 .		
67	14.53	3051	0.94	12190	1 4 .		
676	1.44	301	2.39	20578	M 1 0 2 1 1 . 4 _ M _ _ _ _ 2 2 . C - -	414	200L
484	2.01	422	2.39	22847	1 . 8		
445	2.19	459	2.39	23420	2 . 2		
392	2.49	522	2.39	24373	2 . 5		
326	2.99	627	2.39	25626	2 . 8		
301	3.24	682	2.3	25633	3 . 2		
279	3.5	737	2.13	25833	3 . 6		
233	4.18	873	2.39	26586	4 . 0		
215	4.55	953	2.39	26786	4 . 5		
197	4.94	1032	2.39	27140	5 . 0		
182	5.37	1124	2.39	27493	5 . 6		
145	6.72	1409	2.39	28406	6 . 3		
134	7.26	1522	2.39	28660	7 . 1		
123	7.95	1662	2.26	29113	8 . 0		
114	8.58	1795	2.16	29420	9 . 0		
92	10.59	2219	1.7	30089	1 0 .		
81	11.98	2512	1.5	30457	1 1 .		
78	12.51	2618	1.68	30700	1 2 .		
69	14.16	2966	1.49	30068	1 4 .		
336	2.9	606	2.87	44375	M 1 3 2 1 2 . 8 _ M _ _ _ _ 2 2 . C - -	475	200L
306	3.19	666	2.87	44865	3 . 2		
268	3.64	760	2.87	45546	3 . 6		
242	4.03	844	2.87	46127	4 . 0		
221	4.42	927	2.87	46617	4 . 5		
193	5.04	1053	2.87	47389	5 . 0		
176	5.54	1158	2.87	48169	5 . 6		
157	6.21	1301	2.87	49031	6 . 3		
142	6.88	1444	2.87	49812	7 . 1		
125	7.78	1625	2.87	50854	8 . 0		
113	8.62	1799	2.87	51558	9 . 0		
99	9.89	2071	2.87	52476	1 0 .		
87	11.2	2352	2.53	53404	1 1 .		
79	12.39	2585	2.46	53867	1 2 .		
69	14.03	2930	2.15	54500	1 4 .		
61	15.97	3340	1.86	55592	1 6 .		
54	18	3761	1.65	56250	1 8 .		
49	20	4168	1.52	57575	2 0 .		
43	22.55	4694	1.35	58625	2 2 .		
38	25.45	5287	1.17	58564	2 5 .		
34	28.35	5890	1.05	59228	2 8 .		
31	31.89	6613	0.96	59030	3 2 .		
27	35.52	7355	0.86	60706	3 6 .		
25	39.01	8042	0.8	58551	4 0 .		
64	15.13	3159	3.29	74100	M 1 4 2 1 1 4 . _ M _ _ _ _ 2 2 . C - -	586	200L
59	16.43	3425	3.24	75400	1 6 .		
54	18.11	3774	2.94	77252	1 8 .		
45	21.75	4528	2.34	79634	2 0 .		
41	23.97	4998	2.16	78485	2 2 .		
37	26.07	5441	1.95	78835	2 5 .		
35	28.25	5874	1.7	77725	2 8 .		
28	34.51	7175	1.49	75975	3 2 .		
26	37.39	7746	1.39	75375	3 6 .		
25	39.42	8133	1.24	80706	4 0 .		
23	42.71	8821	1.14	80752	4 5 .		
24	41.36	8550	1.23	65304	M 1 4 3 1 4 0 . _ M _ _ _ _ 2 2 . C - -	631	200L
20	48.21	9887	1.11	65304	4 5 .		
18	54.75	11239	0.98	65304	5 0 .		
16	59.46	12205	0.91	80900	5 6 .		
15	65.55	13508	0.82	80900	6 3 .		

NOTE

Other output speeds are available using 2 and 8 pole motors - Consult Application Engineering

SERIES M

SELECTION TABLES

GEARED MOTORS

30.0 kW

4 POLE

N2 R/MIN	i	M2 Nm	Fm	N	Unit Designation	Kg	Motor Size
Output Speed	Ratio	Output Torque	Service Factor	Overhung Load	Column Entry [1] Through [20] Spaces to be filled when entering order	Weight	
994	1.48	281	2.64	13326	M 0 9 2 1 1 . 4 _ M _ _ _ _ 3 0 . A - -	368	200L
722	2.04	387	2.56	14700	1 . 8		
644	2.28	434	2.48	15200	2 . 2		
574	2.56	486	2.22	15700	2 . 5		
495	2.97	562	2.49	16600	2 . 8		
445	3.3	632	1.72	16900	3 . 2		
399	3.69	705	1.54	17450	3 . 6		
360	4.09	774	2.06	17850	4 . 0		
321	4.58	872	1.93	18100	4 . 5		
290	5.07	964	1.81	18300	5 . 0		
259	5.69	1077	1.69	18450	5 . 6		
222	6.63	1259	1.52	18450	6 . 3		
199	7.4	1405	1.42	18136	7 . 1		
179	8.22	1558	1.33	18263	8 . 0		
160	9.19	1744	1.24	17790	9 . 0		
143	10.27	1955	1.15	14859	1 0 .		
126	11.71	2226	1.05	15300	1 1 .		
115	12.74	2419	1	15300	1 2 .		
101	14.53	2762	0.92	13400	1 4 .		
1019	1.44	273	2.64	17995	M 1 0 2 1 1 . 4 _ M _ _ _ _ 3 0 . A - -	414	200L
730	2.01	382	2.64	19960	1 . 8		
671	2.19	416	2.64	20460	2 . 2		
591	2.49	473	2.64	21260	2 . 5		
491	2.99	563	2.64	22626	2 . 8		
453	3.24	615	2.49	23056	3 . 2		
420	3.5	666	2.34	23556	3 . 6		
352	4.18	790	2.64	25056	4 . 0		
323	4.55	862	2.64	25356	4 . 5		
298	4.94	934	2.64	25621	5 . 0		
274	5.37	1017	2.64	25886	5 . 6		
219	6.72	1274	2.46	26417	6 . 3		
202	7.26	1374	2.34	26649	7 . 1		
185	7.95	1504	2.21	27049	8 . 0		
171	8.58	1621	2.11	27400	9 . 0		
139	10.59	2009	1.83	28100	1 0 .		
123	11.98	2272	1.66	28550	1 1 .		
118	12.51	2368	1.64	28750	1 2 .		
104	14.16	2675	1.51	29227	1 4 .		
506	2.9	548	3.17	39200	M 1 3 2 1 2 . 8 _ M _ _ _ _ 3 0 . A - -	475	200L
461	3.19	602	3.17	40200	3 . 2		
404	3.64	684	3.17	41800	3 . 6		
365	4.03	763	3.17	43000	4 . 0		
333	4.42	839	3.17	44100	4 . 5		
292	5.04	952	3.17	44800	5 . 0		
265	5.54	1047	3.17	45300	5 . 6		
237	6.21	1176	3.17	45800	6 . 3		
214	6.88	1302	3.17	46300	7 . 1		
189	7.78	1470	3.17	47100	8 . 0		
171	8.62	1627	3.17	47800	9 . 0		
149	9.89	1873	3.17	48800	1 0 .		
131	11.2	2125	2.79	49517	1 1 .		
119	12.39	2340	2.71	50288	1 2 .		
105	14.03	2647	2.38	50461	1 4 .		
92	15.97	3017	2.05	51237	1 6 .		
82	18	3403	1.82	51562	1 8 .		
73	20	3765	1.69	51975	2 0 .		
65	22.55	4241	1.5	52132	2 2 .		
58	25.45	4790	1.29	53590	2 5 .		
52	28.35	5333	1.16	55208	2 8 .		
46	31.89	5984	1.06	56057	3 2 .		
41	35.52	6639	0.96	58200	3 6 .		
38	39.01	7296	0.89	56700	4 0 .		
97	15.13	2849	3.65	68600	M 1 4 2 1 1 4 . _ M _ _ _ _ 3 0 . A - -	586	200L
89	16.43	3096	3.21	69600	1 6 .		
81	18.11	3428	3	70600	1 8 .		
68	21.75	4089	2.59	71941	2 0 .		
61	23.97	4520	2.39	72513	2 2 .		
56	26.07	4870	2.16	73600	2 5 .		
52	28.25	5306	1.88	75987	2 8 .		
43	34.51	6488	1.65	75912	3 2 .		
39	37.39	7008	1.54	75650	3 6 .		
37	39.42	7372	1.35	80463	4 0 .		
34	42.71	7976	1.25	80900	4 5 .		
36	41.36	7685	1.27	65824	M 1 4 3 1 4 0 . _ M _ _ _ _ 3 0 . A - -	631	200L
30	48.21	8942	1.23	65824	4 5 .		
27	54.75	10140	1.08	65824	5 0 .		
25	59.46	11057	0.95	65600	5 6 .		
22	65.55	12178	0.88	65600	6 3 .		

NOTE
Other output speeds are available using 2 and 8 pole motors - Consult Application Engineering

SERIES M

SELECTION TABLES

GEARED MOTORS

30.0 kW

6 POLE

N2 R/MIN	i	M2 Nm	Fm	N	Unit Designation	Kg	Motor Size
Output Speed	Ratio	Output Torque	Service Factor	Overhung Load	Column Entry <input type="text" value="1"/> Through <input type="text" value="20"/> Spaces to be filled when entering order	Weight	
663	1.48	422	1.76	15000	M 0 9 2 1 1 . 4 _ M _ _ _ _ 3 0 . C - -	462	225M
481	2.04	584	1.76	16400	1 . 8		
429	2.28	656	1.66	16900	2 . 2		
383	2.56	736	1.48	17400	2 . 5		
330	2.97	845	1.76	17800	2 . 8		
297	3.3	947	1.15	17600	3 . 2		
266	3.69	1060	1.03	17700	3 . 6		
240	4.09	1163	1.56	18200	4 . 0		
214	4.58	1310	1.45	18400	4 . 5		
193	5.07	1447	1.37	18700	5 . 0		
172	5.69	1618	1.27	18900	5 . 6		
148	6.63	1886	1.15	17100	6 . 3		
132	7.4	2108	1.07	15900	7 . 1		
119	8.22	2343	1.01	15700	8 . 0		
107	9.19	2618	0.94	14100	9 . 0		
95	10.27	2927	0.86	10900	1 0 .		
679	1.44	409	1.76	20300	M 1 0 2 1 1 . 4 _ M _ _ _ _ 3 0 . C - -	508	225M
486	2.01	573	1.76	22500	1 . 8		
447	2.19	624	1.76	23100	2 . 2		
394	2.49	709	1.76	24000	2 . 5		
328	2.99	850	1.76	25200	2 . 8		
302	3.24	926	1.69	25100	3 . 2		
280	3.5	1000	1.57	25300	3 . 6		
234	4.18	1185	1.76	26000	4 . 0		
216	4.55	1293	1.76	26200	4 . 5		
198	4.94	1401	1.76	26500	5 . 0		
182	5.37	1526	1.76	26800	5 . 6		
146	6.72	1911	1.76	27500	6 . 3		
135	7.26	2065	1.76	27700	7 . 1		
123	7.95	2255	1.67	28100	8 . 0		
114	8.58	2435	1.59	28300	9 . 0		
93	10.59	3010	1.25	28700	1 0 .		
82	11.98	3408	1.11	28900	1 1 .		
78	12.51	3552	1.24	29100	1 2 .		
69	14.16	4024	1.1	27500	1 4 .		
337	2.9	823	2.11	44090	M 1 3 2 1 2 . 8 _ M _ _ _ _ 3 0 . C - -	569	225M
307	3.19	903	2.11	44558	3 . 2		
269	3.64	1031	2.11	45195	3 . 6		
243	4.03	1145	2.11	45732	4 . 0		
222	4.42	1258	2.11	46201	4 . 5		
194	5.04	1429	2.11	46906	5 . 0		
177	5.54	1571	2.11	47643	5 . 6		
158	6.21	1765	2.11	48417	6 . 3		
142	6.88	1959	2.11	49154	7 . 1		
126	7.78	2205	2.11	50065	8 . 0		
114	8.62	2441	2.11	50550	9 . 0		
99	9.89	2811	2.11	51052	1 0 .		
88	11.2	3191	1.86	51584	1 1 .		
79	12.39	3507	1.81	51887	1 2 .		
70	14.03	3975	1.58	52100	1 4 .		
61	15.97	4532	1.37	52612	1 6 .		
54	18	5103	1.21	52868	1 8 .		
49	20	5654	1.12	53775	2 0 .		
43	22.55	6369	1	54134	2 2 .		
39	25.45	7173	0.86	54020	2 5 .		
339	2.89	817	3.08	56900	M 1 4 2 1 2 . 8 _ M _ _ _ _ 3 0 . C - -	681	225M
302	3.25	921	3.08	58400	3 . 2		
256	3.82	1080	3.08	59600	3 . 6		
243	4.03	1145	3.08	60000	4 . 0		
216	4.54	1287	3.08	60800	4 . 5		
184	5.33	1511	3.08	62000	5 . 0		
163	6	1699	3.08	63200	5 . 6		
150	6.55	1858	3.08	64200	6 . 3		
135	7.27	2062	3.08	65300	7 . 1		
113	8.67	2455	3.08	67100	8 . 0		
102	9.62	2724	3.08	68200	9 . 0		
97	10.06	2857	3.08	68700	1 0 .		
86	11.43	3240	3.08	70100	1 1 .		
74	13.32	3756	2.72	71600	1 2 .		
65	15.13	4286	2.43	72621	1 4 .		
60	16.43	4646	2.39	74066	1 6 .		
54	18.11	5120	2.17	75542	1 8 .		
45	21.75	6144	1.73	76741	2 0 .		
41	23.97	6781	1.59	75725	2 2 .		
38	26.07	7381	1.44	76475	2 5 .		
35	28.25	7969	1.25	75415	2 8 .		
28	34.51	9735	1.1	72393	3 2 .		
26	37.39	10509	1.03	71356	3 6 .		
25	39.42	11034	0.92	80600	4 0 .		
23	42.71	11968	0.84	80671	4 5 .		
24	41.36	11600	0.91	64700	M 1 4 3 1 4 0 . _ M _ _ _ _ 3 0 . C - -	726	225M
20	48.21	13413	0.82	64700	4 5 .		

NOTE
Other output speeds are available using 2 and 8 pole motors - Consult Application Engineering

SERIES M

SELECTION TABLES

GEARED MOTORS

37.0 kW

4 POLE

N2 R/MIN	i	M2 Nm	Fm	N	Unit Designation	Kg	Motor Size
Output Speed	Ratio	Output Torque	Service Factor	Overhung Load	Column Entry [1] Through [20] Spaces to be filled when entering order	Weight	
997	1.48	345	2.15	13220	M 0 9 2 1 1 . 4 _ M _ _ _ _ 3 7 . A - -	427	225S
724	2.04	476	2.09	14560	1 . 8		
646	2.28	534	2.02	15013	2 . 2		
576	2.56	597	1.81	15513	2 . 5		
497	2.97	690	2.03	16413	2 . 8		
447	3.3	777	1.4	16666	3 . 2		
400	3.69	867	1.26	17193	3 . 6		
361	4.09	952	1.68	17593	4 . 0		
322	4.58	1072	1.57	17820	4 . 5		
291	5.07	1185	1.48	18020	5 . 0		
259	5.69	1323	1.37	18100	5 . 6		
223	6.63	1548	1.24	17960	6 . 3		
199	7.4	1727	1.16	17372	7 . 1		
179	8.22	1915	1.09	17393	8 . 0		
161	9.19	2144	1.01	16581	9 . 0		
144	10.27	2403	0.93	12700	1 0 .		
1023	1.44	335	2.15	17904	M 1 0 2 1 1 . 4 _ M _ _ _ _ 3 7 . A - -	473	225S
732	2.01	469	2.15	19839	1 . 8		
673	2.19	511	2.15	20339	2 . 2		
593	2.49	581	2.15	21139	2 . 5		
493	2.99	693	2.15	22473	2 . 8		
455	3.24	756	2.02	22843	3 . 2		
421	3.5	818	1.91	23343	3 . 6		
353	4.18	972	2.15	24843	4 . 0		
325	4.55	1060	2.15	25143	4 . 5		
299	4.94	1148	2.15	25378	5 . 0		
275	5.37	1251	2.15	25613	5 . 6		
219	6.72	1566	2	26082	6 . 3		
203	7.26	1690	1.91	26252	7 . 1		
186	7.95	1849	1.8	26652	8 . 0		
172	8.58	1993	1.72	26933	9 . 0		
139	10.59	2469	1.49	27493	1 0 .		
123	11.98	2792	1.35	27873	1 1 .		
118	12.51	2911	1.34	28073	1 2 .		
104	14.16	3288	1.23	28421	1 4 .		
508	2.9	674	2.58	39071	M 1 3 2 1 2 . 8 _ M _ _ _ _ 3 7 . A - -	534	225S
463	3.19	740	2.58	40071	3 . 2		
405	3.64	841	2.58	41648	3 . 6		
366	4.03	938	2.58	42825	4 . 0		
334	4.42	1031	2.58	43913	4 . 5		
293	5.04	1171	2.58	44590	5 . 0		
266	5.54	1287	2.58	45066	5 . 6		
238	6.21	1446	2.58	45543	6 . 3		
214	6.88	1601	2.58	46020	7 . 1		
190	7.78	1807	2.58	46773	8 . 0		
171	8.62	2000	2.58	47368	9 . 0		
149	9.89	2303	2.58	48181	1 0 .		
132	11.2	2612	2.27	48745	1 1 .		
119	12.39	2876	2.21	49402	1 2 .		
105	14.03	3254	1.93	49098	1 4 .		
92	15.97	3709	1.67	49855	1 6 .		
82	18	4183	1.48	49865	1 8 .		
74	20	4628	1.37	50050	2 0 .		
65	22.55	5213	1.22	49967	2 2 .		
58	25.45	5888	1.05	51215	2 5 .		
52	28.35	6555	0.95	52800	2 8 .		
46	31.89	7355	0.86	53400	3 2 .		
511	2.89	669	3.77	50300	M 1 4 2 1 2 . 8 _ M _ _ _ _ 3 7 . A - -	646	225S
454	3.25	754	3.77	52100	3 . 2		
386	3.82	884	3.77	54600	3 . 6		
366	4.03	937	3.77	55400	4 . 0		
325	4.54	1054	3.77	57400	4 . 5		
277	5.33	1237	3.77	58800	5 . 0		
246	6	1391	3.77	59600	5 . 6		
225	6.55	1521	3.77	60200	6 . 3		
203	7.27	1688	3.77	60900	7 . 1		
170	8.67	2009	3.77	62400	8 . 0		
153	9.62	2230	3.77	63400	9 . 0		
147	10.06	2336	3.77	63900	1 0 .		
129	11.43	2662	3.44	65200	1 1 .		
111	13.32	3066	3.33	66700	1 2 .		
98	15.13	3502	2.97	67981	1 4 .		
90	16.43	3805	2.61	68981	1 6 .		
81	18.11	4214	2.44	69783	1 8 .		
68	21.75	5026	2.11	70489	2 0 .		
62	23.97	5556	1.94	70879	2 2 .		
57	26.07	5986	1.75	71531	2 5 .		
52	28.25	6522	1.53	74395	2 8 .		
43	34.51	7975	1.34	73585	3 2 .		
39	37.39	8614	1.25	73200	3 6 .		
37	39.42	9061	1.1	80293	4 0 .		
35	42.71	9804	1.02	80900	4 5 .		
36	41.36	9447	1.03	65600	M 1 4 3 1 4 0 . _ M _ _ _ _ 3 7 . A - -	691	225S
31	48.21	10991	1	65600	4 5 .		
27	54.75	12464	0.88	65600	5 0 .		

NOTE

Other output speeds are available using 2 and 8 pole motors - Consult Application Engineering

SERIES M

SELECTION TABLES

GEARED MOTORS

37.0 kW

6 POLE

N2 R/MIN	i	M2 Nm	Fm	N	Unit Designation	Kg	Motor Size
Output Speed	Ratio	Output Torque	Service Factor	Overhung Load	Column Entry 1 Through 20 Spaces to be filled when entering order	Weight	
337	2.9	1015	1.71	43841	M 1 3 2 1 2 . 8 _ M _ _ _ _ 3 7 . C - -	646	250M
307	3.19	1114	1.71	44290	3 . 2		
269	3.64	1272	1.71	44889	3 . 6		
243	4.03	1412	1.71	45387	4 . 0		
222	4.42	1552	1.71	45836	4 . 5		
194	5.04	1762	1.71	46484	5 . 0		
177	5.54	1937	1.71	47183	5 . 6		
158	6.21	2177	1.71	47880	6 . 3		
142	6.88	2416	1.71	48579	7 . 1		
126	7.78	2719	1.71	49375	8 . 0		
114	8.62	3011	1.71	49668	9 . 0		
99	9.89	3466	1.71	49805	1 0 .		
88	11.2	3935	1.51	49993	1 1 .		
79	12.39	4326	1.47	50155	1 2 .		
70	14.03	4902	1.28	50000	1 4 .		
61	15.97	5590	1.11	50005	1 6 .		
54	18	6294	0.98	49909	1 8 .		
49	20	6974	0.91	50450	2 0 .		
43	22.55	7855	0.81	50204	2 2 .		
339	2.89	1008	2.5	56704	M 1 4 2 1 2 . 8 _ M _ _ _ _ 3 7 . C - -	761	250M
302	3.25	1136	2.5	58176	3 . 2		
256	3.82	1332	2.5	59320	3 . 6		
243	4.03	1412	2.5	59720	4 . 0		
216	4.54	1588	2.5	60492	4 . 5		
184	5.33	1864	2.5	61608	5 . 0		
163	6	2096	2.5	62780	5 . 6		
150	6.55	2292	2.5	63724	6 . 3		
135	7.27	2544	2.5	64768	7 . 1		
113	8.67	3028	2.5	66456	8 . 0		
102	9.62	3360	2.5	67500	9 . 0		
97	10.06	3524	2.5	68000	1 0 .		
86	11.43	3996	2.5	69288	1 1 .		
74	13.32	4632	2.2	70620	1 2 .		
65	15.13	5286	1.97	71327	1 4 .		
60	16.43	5731	1.94	72900	1 6 .		
54	18.11	6315	1.76	74046	1 8 .		
45	21.75	7577	1.4	74209	2 0 .		
41	23.97	8364	1.29	73310	2 2 .		
38	26.07	9104	1.16	74410	2 5 .		
35	28.25	9829	1.02	73395	2 8 .		
28	34.51	12006	0.89	69259	3 2 .		
26	37.39	12961	0.83	67840	3 6 .		

NOTE

Other output speeds are available using 2 and 8 pole motors - Consult Application Engineering

SERIES M

SELECTION TABLES

GEARED MOTORS

45.0 kW

4 POLE

N2 R/MIN	i	M2 Nm	Fm	N	Unit Designation	Kg	Motor Size
Output Speed	Ratio	Output Torque	Service Factor	Overhung Load	Column Entry [1] Through [20] Spaces to be filled when entering order	Weight	
997	1.48	420	1.77	13100	M 0 9 2 1 1 . 4 _ M _ _ _ _ 4 5 . A - -	462	225M
724	2.04	579	1.72	14400	1 . 8		
646	2.28	650	1.66	14800	2 . 2		
576	2.56	727	1.49	15300	2 . 5		
497	2.97	840	1.67	16200	2 . 8		
447	3.3	945	1.15	16400	3 . 2		
400	3.69	1055	1.03	16900	3 . 6		
361	4.09	1158	1.38	17300	4 . 0		
322	4.58	1303	1.29	17500	4 . 5		
291	5.07	1441	1.21	17700	5 . 0		
259	5.69	1610	1.13	17700	5 . 6		
223	6.63	1883	1.02	17400	6 . 3		
199	7.4	2101	0.95	16500	7 . 1		
179	8.22	2329	0.89	16400	8 . 0		
161	9.19	2608	0.83	15200	9 . 0		
1023	1.44	408	1.77	17800	M 1 0 2 1 1 . 4 _ M _ _ _ _ 4 5 . A - -	508	225M
732	2.01	571	1.77	19700	1 . 8		
673	2.19	622	1.77	20200	2 . 2		
593	2.49	707	1.77	21000	2 . 5		
493	2.99	842	1.77	22300	2 . 8		
455	3.24	919	1.66	22600	3 . 2		
421	3.5	995	1.57	23100	3 . 6		
353	4.18	1182	1.77	24600	4 . 0		
325	4.55	1289	1.77	24900	4 . 5		
299	4.94	1397	1.77	25100	5 . 0		
275	5.37	1521	1.77	25300	5 . 6		
219	6.72	1905	1.65	25700	6 . 3		
203	7.26	2055	1.57	25800	7 . 1		
186	7.95	2249	1.48	26200	8 . 0		
172	8.58	2424	1.41	26400	9 . 0		
139	10.59	3003	1.23	26800	1 0 .		
123	11.98	3396	1.11	27100	1 1 .		
118	12.51	3540	1.1	27300	1 2 .		
104	14.16	3999	1.01	27500	1 4 .		
90	16.43	4645	0.81	24900	1 6 .		
508	2.9	820	2.12	38925	M 1 3 2 1 2 . 8 _ M _ _ _ _ 4 5 . A - -	569	225M
463	3.19	900	2.12	39925	3 . 2		
405	3.64	1023	2.12	41475	3 . 6		
366	4.03	1141	2.12	42625	4 . 0		
334	4.42	1254	2.12	43700	4 . 5		
293	5.04	1424	2.12	44350	5 . 0		
266	5.54	1565	2.12	44800	5 . 6		
238	6.21	1759	2.12	45250	6 . 3		
214	6.88	1947	2.12	45700	7 . 1		
190	7.78	2197	2.12	46400	8 . 0		
171	8.62	2433	2.12	46875	9 . 0		
149	9.89	2801	2.12	47475	1 0 .		
132	11.2	3177	1.87	47863	1 1 .		
119	12.39	3498	1.82	48391	1 2 .		
105	14.03	3958	1.59	47540	1 4 .		
92	15.97	4511	1.37	48275	1 6 .		
82	18	5088	1.22	47925	1 8 .		
74	20	5629	1.13	47850	2 0 .		
65	22.55	6341	1	47493	2 2 .		
58	25.45	7161	0.87	48500	2 5 .		
511	2.89	813	3.1	50194	M 1 4 2 1 2 . 8 _ M _ _ _ _ 4 5 . A - -	681	225M
454	3.25	917	3.1	51979	3 . 2		
386	3.82	1075	3.1	54449	3 . 6		
366	4.03	1139	3.1	55249	4 . 0		
325	4.54	1281	3.1	57218	4 . 5		
277	5.33	1504	3.1	58588	5 . 0		
246	6	1691	3.1	59358	5 . 6		
225	6.55	1850	3.1	59943	6 . 3		
203	7.27	2053	3.1	60628	7 . 1		
170	8.67	2444	3.1	62052	8 . 0		
153	9.62	2712	3.1	63022	9 . 0		
147	10.06	2841	3.1	63507	1 0 .		
129	11.43	3238	2.83	64762	1 1 .		
111	13.32	3729	2.74	66171	1 2 .		
98	15.13	4259	2.44	67275	1 4 .		
90	16.43	4628	2.15	68275	1 6 .		
81	18.11	5125	2.01	68850	1 8 .		
68	21.75	6113	1.73	68830	2 0 .		
62	23.97	6757	1.6	69010	2 2 .		
57	26.07	7280	1.44	69167	2 5 .		
52	28.25	7932	1.26	72575	2 8 .		
43	34.51	9699	1.1	70925	3 2 .		
39	37.39	10477	1.03	70400	3 6 .		
37	39.42	11020	0.9	80100	4 0 .		

NOTE
Other output speeds are available using 2 and 8 pole motors - Consult Application Engineering

SERIES M

SELECTION TABLES

GEARED MOTORS

45.0 kW

6 POLE

N2 R/MIN	i	M2 Nm	Fm	N	Unit Designation	Kg	Motor Size
Output Speed	Ratio	Output Torque	Service Factor	Overhung Load	Column Entry 1 Through 20 Spaces to be filled when entering order	Weight	
337	2.9	1235	1.41	43556	M 1 3 2 1 2 . 8 _ M _ _ _ _ 4 5 . C - -	771	280S
307	3.19	1355	1.41	43983	3 . 2		
269	3.64	1547	1.41	44538	3 . 6		
243	4.03	1717	1.41	44993	4 . 0		
222	4.42	1888	1.41	45420	4 . 5		
194	5.04	2143	1.41	46002	5 . 0		
177	5.54	2356	1.41	46657	5 . 6		
158	6.21	2647	1.41	47267	6 . 3		
142	6.88	2938	1.41	47921	7 . 1		
126	7.78	3307	1.41	48586	8 . 0		
114	8.62	3662	1.41	48660	9 . 0		
99	9.89	4216	1.41	48380	1 0 .		
88	11.2	4786	1.24	48173	1 1 .		
79	12.39	5261	1.21	48175	1 2 .		
70	14.03	5962	1.05	47600	1 4 .		
61	15.97	6798	0.91	47025	1 6 .		
54	18	7655	0.81	46527	1 8 .		
339	2.89	1226	2.06	56480	M 1 4 2 1 2 . 8 _ M _ _ _ _ 4 5 . C - -	886	280S
302	3.25	1381	2.06	57920	3 . 2		
256	3.82	1620	2.06	59000	3 . 6		
243	4.03	1717	2.06	59400	4 . 0		
216	4.54	1931	2.06	60140	4 . 5		
184	5.33	2267	2.06	61160	5 . 0		
163	6	2549	2.06	62300	5 . 6		
150	6.55	2787	2.06	63180	6 . 3		
135	7.27	3094	2.06	64160	7 . 1		
113	8.67	3683	2.06	65720	8 . 0		
102	9.62	4087	2.06	66700	9 . 0		
97	10.06	4286	2.06	67200	1 0 .		
86	11.43	4860	2.06	68360	1 1 .		
74	13.32	5634	1.81	69500	1 2 .		
65	15.13	6429	1.62	69848	1 4 .		
60	16.43	6970	1.59	71566	1 6 .		
54	18.11	7681	1.45	72336	1 8 .		
45	21.75	9216	1.15	71316	2 0 .		
41	23.97	10172	1.06	70550	2 2 .		
38	26.07	11072	0.96	72050	2 5 .		
35	28.25	11954	0.83	71086	2 8 .		

NOTE

Other output speeds are available using 2 and 8 pole motors - Consult Application Engineering

SERIES M

SELECTION TABLES

GEARED MOTORS

55.0 kW

4 POLE

N2 R/MIN	i	M2 Nm	Fm	N	Unit Designation	Kg	Motor Size
Output Speed	Ratio	Output Torque	Service Factor	Overhung Load	Column Entry <input type="text" value="1"/> Through <input type="text" value="20"/> Spaces to be filled when entering order	Weight	
508	2.9	1002	1.73	38741	M 1 3 2 1 2 . 8 _ M _ _ _ _ 5 5 . A - -	646	250M
463	3.19	1100	1.73	39741	3 . 2		
405	3.64	1250	1.73	41258	3 . 6		
366	4.03	1394	1.73	42375	4 . 0		
334	4.42	1533	1.73	43433	4 . 5		
293	5.04	1740	1.73	44050	5 . 0		
266	5.54	1913	1.73	44466	5 . 6		
238	6.21	2150	1.73	44883	6 . 3		
214	6.88	2380	1.73	45300	7 . 1		
190	7.78	2686	1.73	45933	8 . 0		
171	8.62	2974	1.73	46258	9 . 0		
149	9.89	3423	1.73	46591	1 0 .		
132	11.2	3883	1.53	46760	1 1 .		
119	12.39	4275	1.49	47126	1 2 .		
105	14.03	4837	1.3	45593	1 4 .		
92	15.97	5513	1.12	46300	1 6 .		
82	18	6219	1	45500	1 8 .		
74	20	6880	0.92	45100	2 0 .		
65	22.55	7750	0.82	44400	2 2 .		
511	2.89	994	2.53	50062	M 1 4 2 1 2 . 8 _ M _ _ _ _ 5 5 . A - -	761	250M
454	3.25	1120	2.53	51828	3 . 2		
386	3.82	1314	2.53	54260	3 . 6		
366	4.03	1393	2.53	55060	4 . 0		
325	4.54	1566	2.53	56992	4 . 5		
277	5.33	1839	2.53	58324	5 . 0		
246	6	2067	2.53	59056	5 . 6		
225	6.55	2261	2.53	59622	6 . 3		
203	7.27	2510	2.53	60288	7 . 1		
170	8.67	2987	2.53	61618	8 . 0		
153	9.62	3315	2.53	62550	9 . 0		
147	10.06	3472	2.53	63016	1 0 .		
129	11.43	3957	2.31	64215	1 1 .		
111	13.32	4557	2.24	65511	1 2 .		
98	15.13	5206	2	66391	1 4 .		
90	16.43	5657	1.76	67391	1 6 .		
81	18.11	6264	1.64	67683	1 8 .		
68	21.75	7472	1.42	66757	2 0 .		
62	23.97	8259	1.31	66674	2 2 .		
57	26.07	8898	1.18	66211	2 5 .		
52	28.25	9695	1.03	70300	2 8 .		
43	34.51	11855	0.9	67600	3 2 .		
39	37.39	12805	0.84	66900	3 6 .		

55.0 kW

6 POLE

337	2.9	1509	1.15	43200	M 1 3 2 1 2 . 8 _ M _ _ _ _ 5 5 . C - -	861	280M
307	3.19	1657	1.15	43600	3 . 2		
269	3.64	1891	1.15	44100	3 . 6		
243	4.03	2099	1.15	44500	4 . 0		
222	4.42	2307	1.15	44900	4 . 5		
194	5.04	2620	1.15	45400	5 . 0		
177	5.54	2880	1.15	46000	5 . 6		
158	6.21	3236	1.15	46500	6 . 3		
142	6.88	3591	1.15	47100	7 . 1		
126	7.78	4042	1.15	47600	8 . 0		
114	8.62	4476	1.15	47400	9 . 0		
99	9.89	5153	1.15	46600	1 0 .		
88	11.2	5850	1.02	45900	1 1 .		
79	12.39	6430	0.99	45700	1 2 .		
70	14.03	7287	0.86	44600	1 4 .		
339	2.89	1498	1.68	56200	M 1 4 2 1 2 . 8 _ M _ _ _ _ 5 5 . C - -	976	280M
302	3.25	1688	1.68	57600	3 . 2		
256	3.82	1980	1.68	58600	3 . 6		
243	4.03	2099	1.68	59000	4 . 0		
216	4.54	2360	1.68	59700	4 . 5		
184	5.33	2771	1.68	60600	5 . 0		
163	6	3116	1.68	61700	5 . 6		
150	6.55	3407	1.68	62500	6 . 3		
135	7.27	3782	1.68	63400	7 . 1		
113	8.67	4501	1.68	64800	8 . 0		
102	9.62	4995	1.68	65700	9 . 0		
97	10.06	5239	1.68	66200	1 0 .		
86	11.43	5940	1.68	67200	1 1 .		
74	13.32	6886	1.48	68100	1 2 .		
65	15.13	7858	1.32	68000	1 4 .		
60	16.43	8519	1.3	69900	1 6 .		
54	18.11	9388	1.18	70200	1 8 .		
45	21.75	11264	0.94	67700	2 0 .		
41	23.97	12433	0.87	67100	2 2 .		

NOTE

Other output speeds are available using 2 and 8 pole motors - Consult Application Engineering

SERIES M

SELECTION TABLES

GEARED MOTORS

75.0 kW

4 POLE

N2 R/MIN	i	M2 Nm	Fm	N	Unit Designation	Kg	Motor Size
Output Speed	Ratio	Output Torque	Service Factor	Overhung Load	Column Entry <input type="text" value="1"/> Through <input type="text" value="20"/> Spaces to be filled when entering order	Weight	
511	2.9	1358	1.28	38375	M 1 3 2 1 2 . 8 _ M _ _ _ _ 7 5 . A - -	771	280S
466	3.19	1491	1.28	39375			
408	3.64	1694	1.28	40825			
369	4.03	1889	1.28	41875			
336	4.42	2076	1.28	42900			
295	5.04	2357	1.28	43450			
268	5.54	2592	1.28	43800			
239	6.21	2912	1.28	44150			
216	6.88	3224	1.28	44500			
191	7.78	3638	1.28	45000			
172	8.62	4028	1.28	45025			
150	9.89	4637	1.28	44825			
133	11.2	5259	1.13	44554			
120	12.39	5791	1.1	44597			
106	14.03	6552	0.96	41700			
514	2.89	1347	1.87	49798	M 1 4 2 1 2 . 8 _ M _ _ _ _ 7 5 . A - -	886	280S
457	3.25	1518	1.87	51526			
389	3.82	1780	1.87	53883			
369	4.03	1886	1.87	54683			
327	4.54	2122	1.87	56539			
278	5.33	2490	1.87	57796			
247	6	2801	1.87	58452			
227	6.55	3062	1.87	58981			
204	7.27	3399	1.87	59609			
171	8.67	4046	1.87	60750			
154	9.62	4490	1.87	61607			
148	10.06	4703	1.87	62035			
130	11.43	5360	1.71	63120			
111	13.32	6173	1.65	64190			
98	15.13	7052	1.47	64625			
90	16.43	7662	1.3	65625			
82	18.11	8484	1.21	65350			
68	21.75	10120	1.05	62610			
62	23.97	11186	0.97	62003			
57	26.07	12052	0.87	60300			

90.0 kW

4 POLE

511	2.9	1630	1.07	38100	M 1 3 2 1 2 . 8 _ M _ _ _ _ 9 0 . A - -	861	280M
466	3.19	1789	1.07	39100			
408	3.64	2033	1.07	40500			
369	4.03	2267	1.07	41500			
336	4.42	2492	1.07	42500			
295	5.04	2829	1.07	43000			
268	5.54	3110	1.07	43300			
239	6.21	3494	1.07	43600			
216	6.88	3869	1.07	43900			
191	7.78	4365	1.07	44300			
172	8.62	4834	1.07	44100			
150	9.89	5565	1.07	43500			
133	11.2	6311	0.94	42900			
120	12.39	6949	0.91	42700			
514	2.89	1616	1.56	49600	M 1 4 2 1 2 . 8 _ M _ _ _ _ 9 0 . A - -	976	280M
457	3.25	1821	1.56	51300			
389	3.82	2136	1.56	53600			
369	4.03	2264	1.56	54400			
327	4.54	2546	1.56	56200			
278	5.33	2989	1.56	57400			
247	6	3361	1.56	58000			
227	6.55	3675	1.56	58500			
204	7.27	4079	1.56	59100			
171	8.67	4855	1.56	60100			
154	9.62	5388	1.56	60900			
148	10.06	5644	1.56	61300			
130	11.43	6432	1.42	62300			
111	13.32	7407	1.38	63200			
98	15.13	8462	1.23	63300			
90	16.43	9195	1.08	64300			
82	18.11	10181	1.01	63600			
68	21.75	12144	0.87	59500			
62	23.97	13424	0.8	58500			

NOTE

Other output speeds are available using 2 and 8 pole motors - Consult Application Engineering

SERIES M

DIMENSIONS - DOUBLE REDUCTION BASE MOUNT

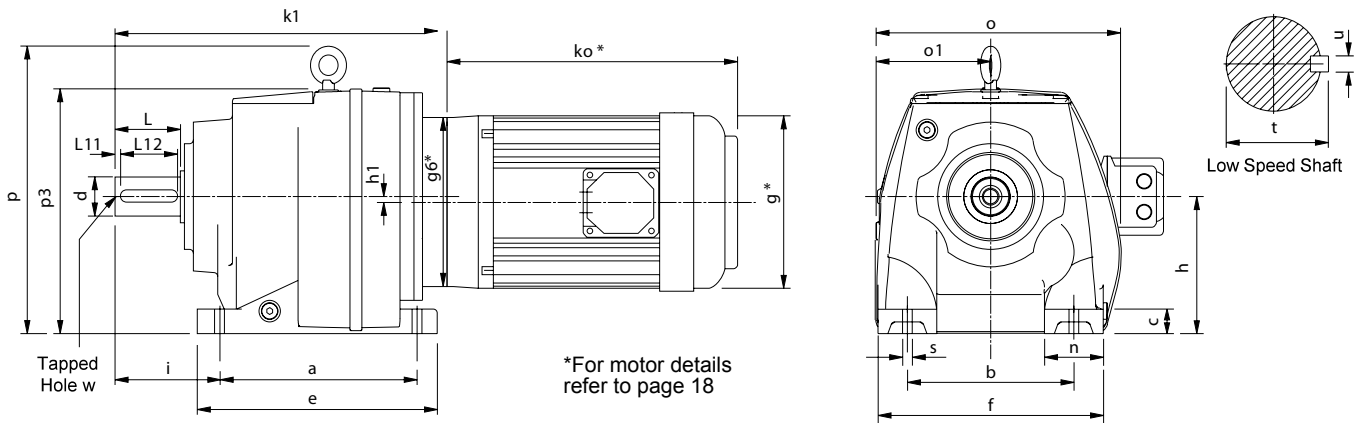

all parallel keys are to DIN 6885

Size	a	b	c	e	f	h	h1	i	n	o	o1	p	p3	s	Low Speed Shaft						
															d	L	L11	L12	t	u	w
M0122	110	110	12	131	135	75	-	58	25	152	76	-	149	10	20 k6	40	4	32	22.5	6	M6 x 1 16 deep
M0222	130	110	16	152	145	90	-	75	35	170	84	-	180	10	25 k6	50	4	40	28	8	M10 x 1.5 22 deep
M0322	130	110	16	152	145	90	-	75	35	170	84	-	180	10	25 k6	50	4	40	28	8	M10 x 1.5 22 deep
M0422	165	135	20	200	190	115	-	90	55	204	97	-	208	15	30 k6	60	4	50	33	8	M10 x 1.5 22 deep
M0522	165	135	20	200	190	115	-	100	55	204	97	-	208	15	35 k6	70	7	60	38	10	M12 x 1.75 28 deep
M0622	195	150	24	235	210	130	14.5	100	60	220	110	246	214	15	35 k6	70	7	60	38	10	M12 x 1.75 28 deep
M0722	205	170	25	245	230	140	-	115	60	252	119	295	250	19	40 k6	80	5	70	43	12	M16 x 2.0 36 deep
M0822	260	215	35	310	290	180	-	140	75	320	167	360	310	19	50 k6	100	10	80	53.5	14	M16 x 2.0 36 deep
M0921	310	250	40	365	340	225	-	160	90	372	200	433	394	23	60 m6	120	10	100	64	18	M20 x 2.5 42 deep
M1021	370	290	45	440	400	250	-	185	110	428	225	505	446	27	70 m6	140	15	110	74.5	20	M20 x 2.5 42 deep
M1321	410	340	50	490	450	265	-	220	110	470	242	563	483	34	90 m6	170	15	140	95	25	M24 x 3.0 50 deep
M1421	500	380	50	590	530	300	-	260	150	546	278	630	551	41	100 m6	210	15	180	106	28	M24 x 3.0 50 deep

MOTOR FRAME SIZE	M0122	M0222	M0322	M0422	M0522	M0622	M0722	M0822	M0921	M1021	M1321	M1421
	K1	K1	K1	K1	K1	K1	K1	K1	K1	K1	K1	K1
63	209	240	240	270	280	301	-	-	-	-	-	-
71	213	244	244	276	286	307	-	-	-	-	-	-
80	226	257	257	294	304	325	362	477	523	-	-	-
90	236	267	267	304	314	335	372	477	523	-	-	-
100	244	275	275	331	341	362	384	483	529	596	717	832
112	244	275	275	331	341	362	384	483	529	596	717	832
132	-	-	-	331	341	362	406	483	564	596	717	832
160	-	-	-	-	-	-	414	513	564	631	710	825
180	-	-	-	-	-	-	-	-	564	564	710	825
200	-	-	-	-	-	-	-	-	564	564	710	825
225	-	-	-	-	-	-	-	-	591	591	737	852
250	-	-	-	-	-	-	-	-	-	-	909	1024
280	-	-	-	-	-	-	-	-	-	-	909	1024

SERIES M

DIMENSIONS - TRIPLE REDUCTION BASE MOUNT

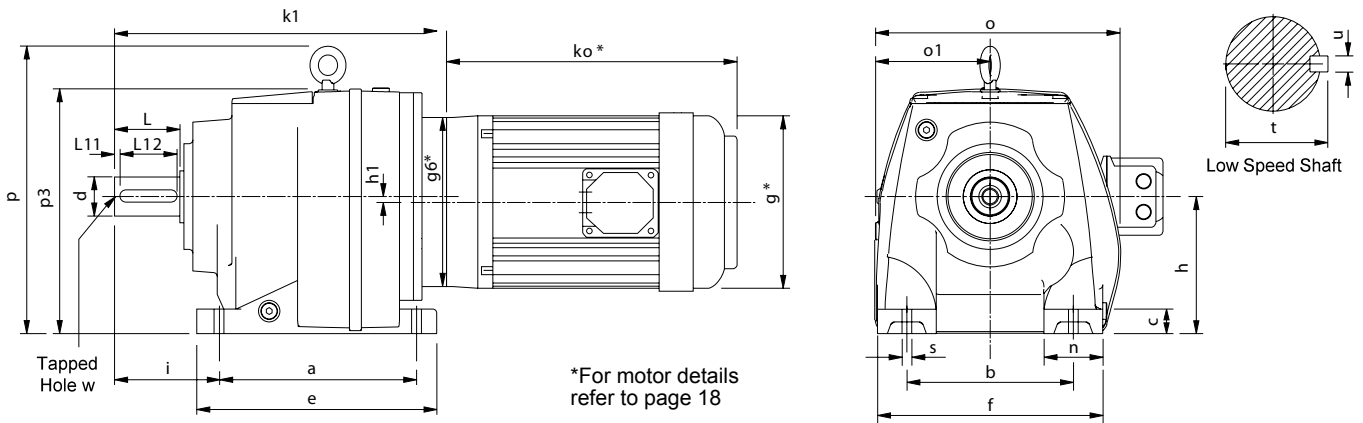

all parallel keys are to DIN 6885

Size	a	b	c	e	f	h	h1	i	n	o	o1	p	p3	s	Low Speed Shaft						
															d	L	L11	L12	t	u	w
M0132	110	110	12	131	135	75	-	58	25	152	76	-	149	10	20 k6	40	4	32	22.5	6	M6 x 1 16 deep
M0232	130	110	16	152	145	90	-	75	35	170	84	-	180	10	25 k6	50	4	40	28	8	M10 x 1.5 22 deep
M0332	130	110	16	152	145	90	-	75	35	170	84	-	180	10	25 k6	50	4	40	28	8	M10 x 1.5 22 deep
M0432	165	135	20	200	190	115	-	90	55	204	97	-	208	15	30 k6	60	4	50	33	8	M10 x 1.5 22 deep
M0532	165	135	20	200	190	115	-	100	55	204	97	-	208	15	35 k6	70	7	60	38	10	M12 x 1.75 28 deep
M0632	195	150	24	235	210	130	14.5	100	60	220	110	246	214	15	35 k6	70	7	60	38	10	M12 x 1.75 28 deep
M0732	205	170	25	245	230	140	-	115	60	252	119	295	250	19	40 k6	80	5	70	43	12	M16 x 2.0 36 deep
M0832	260	215	35	310	290	180	-	140	75	320	167	360	310	19	50 k6	100	10	80	53.5	14	M16 x 2.0 36 deep
M0931	310	250	40	365	340	225	-	160	90	372	200	433	394	23	60 m6	120	10	100	64	18	M20 x 2.5 42 deep
M1031	370	290	45	440	400	250	-	185	110	428	225	505	446	27	70 m6	140	15	110	74.5	20	M20 x 2.5 42 deep
M1331	410	340	50	490	450	265	-	220	110	470	242	563	483	34	90 m6	170	15	140	95	25	M24 x 3.0 50 deep
M1431	500	380	50	590	530	300	-	260	150	546	278	630	551	41	100 m6	210	15	180	106	28	M24 x 3.0 50 deep

MOTOR FRAME SIZE	M0132	M0232	M0332	M0432	M0532	M0632	M0732	M0832	M0931	M1031	M1331	M1431
	K1	K1	K1	K1	K1	K1	K1	K1	K1	K1	K1	K1
63	224	253	253	300	310	331	353	-	-	-	-	-
71	228	257	257	304	314	335	359	-	-	-	-	-
80	241	270	270	317	327	348	377	462	549	647	-	-
90	251	280	280	327	337	358	387	472	549	647	-	-
100	259	288	288	335	345	366	414	484	555	653	779	904
112	259	288	288	335	345	366	414	484	555	653	779	904
132	-	-	-	-	-	-	414	506	-	653	779	904
160	-	-	-	-	-	-	-	-	-	688	772	897
180	-	-	-	-	-	-	-	-	-	688	772	897
200	-	-	-	-	-	-	-	-	-	688	772	897
225	-	-	-	-	-	-	-	-	-	715	799	924
250	-	-	-	-	-	-	-	-	-	-	971	1096
280	-	-	-	-	-	-	-	-	-	-	971	1096

SERIES M

DIMENSIONS - QUADRUPLE REDUCTION BASE MOUNT

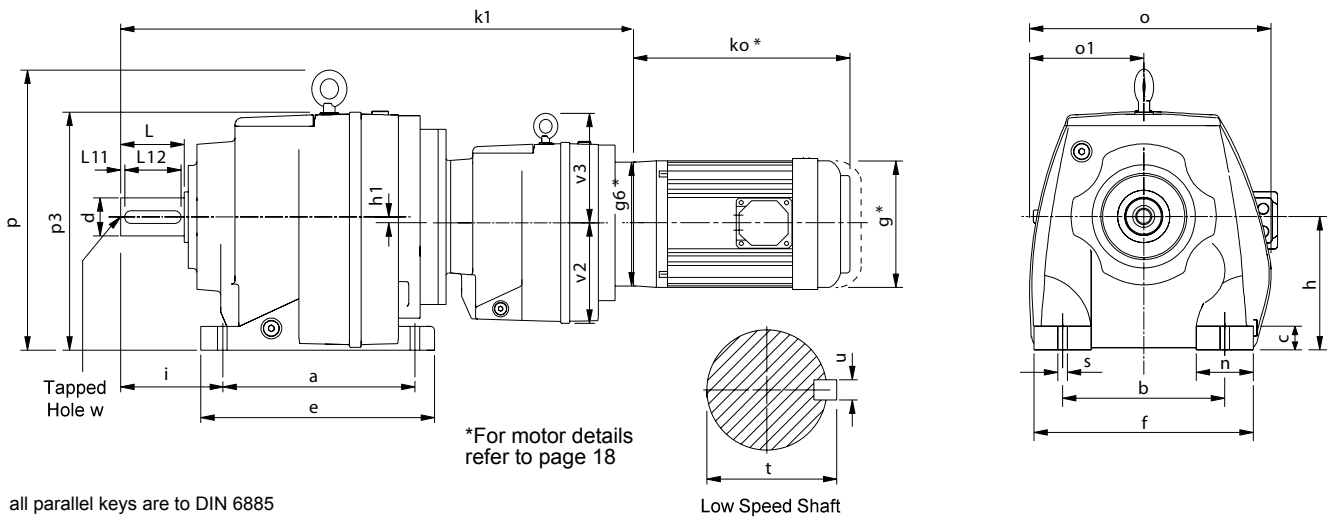

Size	a	b	c	e	f	h	h1	i	n	o	o1	p	p3	s	v2	v3	Low Speed Shaft						
																	d	L	L11	L12	t	u	w
M0342	130	110	16	152	145	90	-	75	35	170	84	-	180	10	76	-	25	50	4	40	28	8	M10 x 1.5 22 deep
M0442	165	135	20	200	190	115	-	90	55	204	97	-	208	15	91	-	30	60	4	50	33	8	M10 x 1.5 22 deep
M0542	165	135	20	200	190	115	-	100	55	204	97	-	208	15	91	-	35	70	7	60	38	10	M12 x 1.75 28 deep
M0642	195	150	24	235	210	130	14.5	100	60	220	110	246	214	15	91	-	35	70	7	60	38	10	M12 x 1.75 28 deep
M0742	205	170	25	245	230	140	-	115	60	252	119	295	250	19	91	-	40	80	5	70	43	12	M16 x 2.0 36 deep
M0842	260	215	35	310	290	180	-	140	75	320	167	360	310	19	115	-	50	100	10	80	53.5	14	M16 x 2.0 36 deep
M0941	310	250	40	365	340	225	-	160	90	372	200	433	394	23	115	-	60	120	10	100	64	18	M20 x 2.5 42 deep
M1041	370	290	45	440	400	250	-	185	110	428	225	505	446	27	140	155	70	140	15	110	74.5	20	M20 x 2.5 42 deep
M1341	410	340	50	490	450	265	-	220	110	470	242	563	483	34	140	155	90	170	15	140	95	25	M24 x 3.0 50 deep
M1441	500	380	50	590	530	300	-	260	150	546	278	630	551	41	140	155	100	210	15	180	106	28	M24 x 3.0 50 deep

MOTOR FRAME SIZE	M0342	M0442	M0542	M0642	M0742	M0842	M0941	M1041	M1341	M1441
	K1	K1	K1	K1	K1	K1	K1	K1	K1	K1
63	426	494	504	525	562	652	733	-	-	-
71	430	498	508	529	566	658	739	-	-	-
80	443	511	521	542	579	676	757	878	999	1114
90	453	521	531	552	589	686	767	888	1009	1124
100	-	-	-	-	-	713	794	900	1021	1136
112	-	-	-	-	-	713	794	900	1021	1136
132	-	-	-	-	-	713	794	922	1043	1158
160	-	-	-	-	-	-	-	930	1051	1166

SERIES M

DIMENSIONS - QUINTUPLE REDUCTION BASE MOUNT

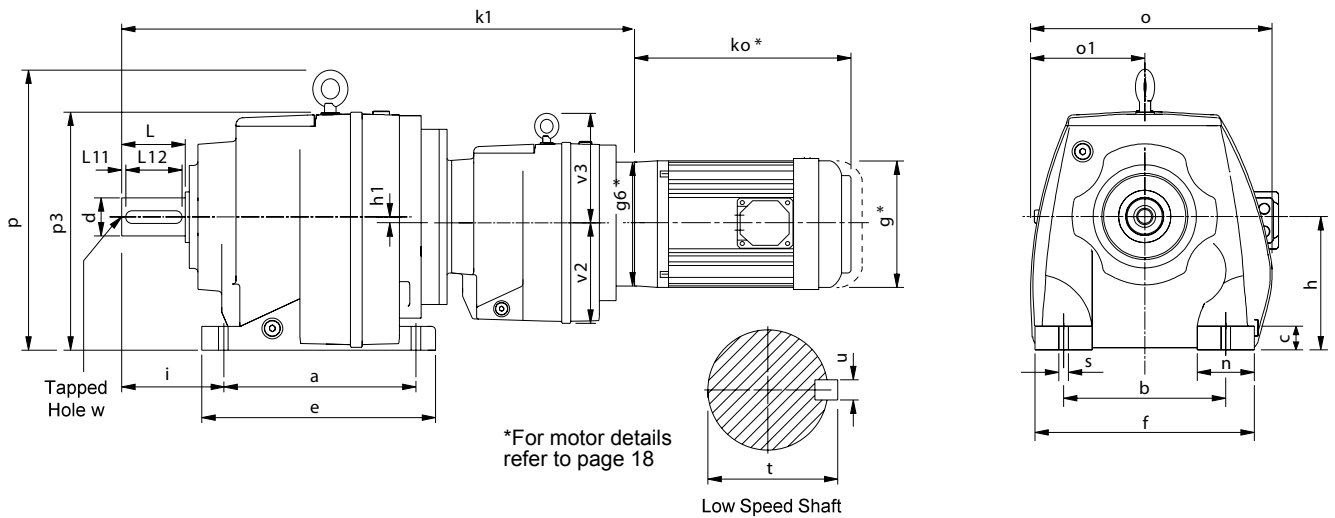

all parallel keys are to DIN 6885

Size	a	b	c	e	f	h	h1	i	n	o	o1	p	p3	s	v2	v3	Low Speed Shaft						
																	d	L	L11	L12	t	u	w
M0352	130	110	16	152	145	90	-	75	35	170	84	-	180	10	76	-	25	50	4	40	28	8	M10 x 1.5 22 deep
M0452	165	135	20	200	190	115	-	90	55	204	97	-	208	15	91	-	30	60	4	50	33	8	M10 x 1.5 22 deep
M0552	165	135	20	200	190	115	-	100	55	204	97	-	208	15	91	-	35	70	7	60	38	10	M12 x 1.75 28 deep
M0652	195	150	24	235	210	130	14.5	100	60	220	110	246	214	15	91	-	35	70	7	60	38	10	M12 x 1.75 28 deep
M0752	205	170	25	245	230	140	-	115	60	252	119	295	250	19	91	-	40	80	5	70	43	12	M16 x 2.0 36 deep
M0852	260	215	35	310	290	180	-	140	75	320	167	360	310	19	115	-	50	100	10	80	53.5	14	M16 x 2.0 36 deep
M0951	310	250	40	365	340	225	-	160	90	372	200	433	394	23	115	-	60	120	10	100	64	18	M20 x 2.5 42 deep
M1051	370	290	45	440	400	250	-	185	110	428	225	505	446	27	140	155	70	140	15	110	74.5	20	M20 x 2.5 42 deep
M1351	410	340	50	490	450	265	-	220	110	470	242	563	483	34	140	155	90	170	15	140	95	25	M24 x 3.0 50 deep
M1451	500	380	50	590	530	300	-	260	150	546	278	630	551	41	140	155	100	210	15	180	106	28	M24 x 3.0 50 deep

MOTOR FRAME SIZE	M0352	M0452	M0552	M0652	M0752	M0852	M0951	M1051	M1351	M1451
		K1	K1	K1	K1	K1	K1	K1	K1	K1
63	441	507	517	538	575	682	763	869	990	1105
71	445	511	521	542	579	686	767	875	996	1111
80	458	524	534	555	592	699	780	893	1014	1129
90	468	534	544	565	602	709	790	903	1024	1139
100	-	-	-	-	-	-	-	930	1051	1166
112	-	-	-	-	-	-	-	930	1051	1166

SERIES M

DIMENSIONS - DOUBLE REDUCTION FLANGE MOUNT

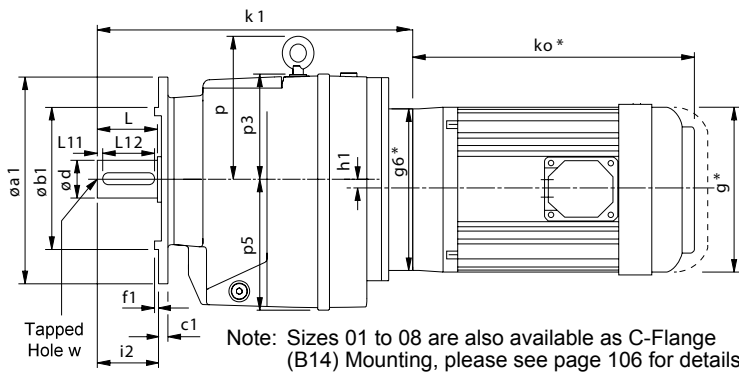

Sizes
1, 2, 3, 4, 5, 6, 7 and 8

Sizes
9, 10, 13 and 14

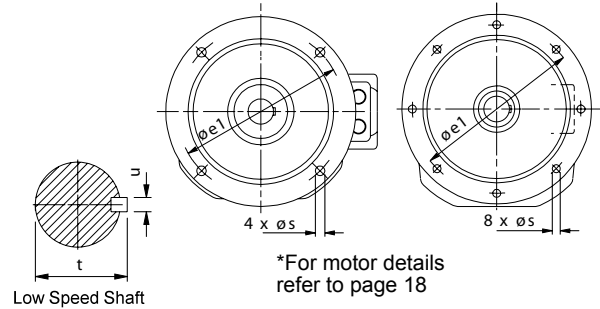

all parallel keys are to DIN 6885

Size	Øa1	Øb1	c1	Øe1	f1	h1	i2	p	p3	p5	s	Low Speed Shaft						
												d	L	L11	L12	t	u	w
M0122	120	80	9	100	3	-	40	-	74	76	9	20 k6	40	4	32	22.5	6	M6 x 1 16 deep
	140	95	9	115	3		40				9							
	160	110	10	130	3.5		40				9							
	200	130	10	165	3.5		40				11							
M0222	120	80	10	100	3	-	50	-	90	91	6.6	25 k6	50	4	40	28	8	M10 x 1.5 16 deep
	140	95	10	115	3		50				9							
	160	110	10	130	3.5		50				9							
	200	130	10	165	3.5		50				11							
M0322	120	80	10	100	3	-	50	-	90	91	6.6	25 k6	50	4	40	28	8	M10 x 1.5 16 deep
	140	95	10	115	3		50				9							
	160	110	10	130	3.5		50				9							
	200	130	10	165	3.5		50				11							
M0422	140	95	11	115	3	-	60	-	93	115	9	30 k6	60	4	50	33	8	M10 x 1.5 16 deep
	160	110	11	130	3.5		60				9							
	200	130	11	165	3.5		60				11							
	250	180	11	215	4		60				13.5							
M0522	140	95	11	115	3	-	70	-	93	115	9	35 k6	70	7	60	38	10	M12 x 1.75 28 deep
	160	110	11	130	3.5		70				9							
	200	130	11	165	3.5		70				11							
	250	180	11	215	4		70				13.5							
M0622	200	130	11	165	4	14.5	70	116	84	130	11	35 k6	70	7	60	38	10	M12 x 1.75 28 deep
	250	180	11	215	4		70				13.5							
	300	230	11	265	4		70				13.5							
M0722	200	130	11	165	3.5	-	80	155	110	140	11	40 k6	80	5	70	43	12	M16 x 2.0 36 deep
	250	180	11	215	4		80				13.5							
	300	230	11	265	4		80				13.5							
M0822	300	230	17	265	4	-	100	180	130	182	13.5	50 k6	100	10	80	53.5	14	M16 x 2.0 36 deep
	350	250	17	300	5		100				17.5							
M0921	450	350	18	400	5	-	140	198	-	230	18	60 m6	120	10	100	64	18	M20 x 2.5 42 deep
M1021	450	350	22	400	5	-	140	245	-	260	18	60 m6	140	15	110	74.5	20	M20 x 2.5 42 deep
M1321	550	450	25	500	5	-	170	288	-	278	18	90 m6	170	15	140	95	25	M24 x 3.0 50 deep
M1421	550	450	25	500	5	-	210	320	-	318	18	100 m6	210	15	180	106	28	M24 x 3.0 50 deep

MOTOR FRAME SIZE	M0122	M0222	M0322	M0422	M0522	M0622	M0722	M0822	M0921	M1021	M1321	M1421
	K1	K1	K1	K1	K1	K1	K1	K1	K1	K1	K1	K1
63	209	240	240	270	280	301	-	-	-	-	-	-
71	213	244	244	276	286	307	-	-	-	-	-	-
80	226	257	257	294	304	325	362	477	523	-	-	-
90	236	267	267	304	314	335	372	477	523	-	-	-
100	244	275	275	331	341	362	384	483	529	596	717	832
112	244	275	275	331	341	362	384	483	529	596	717	832
132	-	-	-	331	341	362	406	483	564	596	717	832
160	-	-	-	-	-	-	414	513	564	631	710	825
180	-	-	-	-	-	-	-	-	564	564	710	825
200	-	-	-	-	-	-	-	-	564	564	710	825
225	-	-	-	-	-	-	-	-	591	591	737	852
250	-	-	-	-	-	-	-	-	-	-	909	1024
280	-	-	-	-	-	-	-	-	-	-	909	1024

SERIES M

DIMENSIONS - TRIPLE REDUCTION FLANGE MOUNT

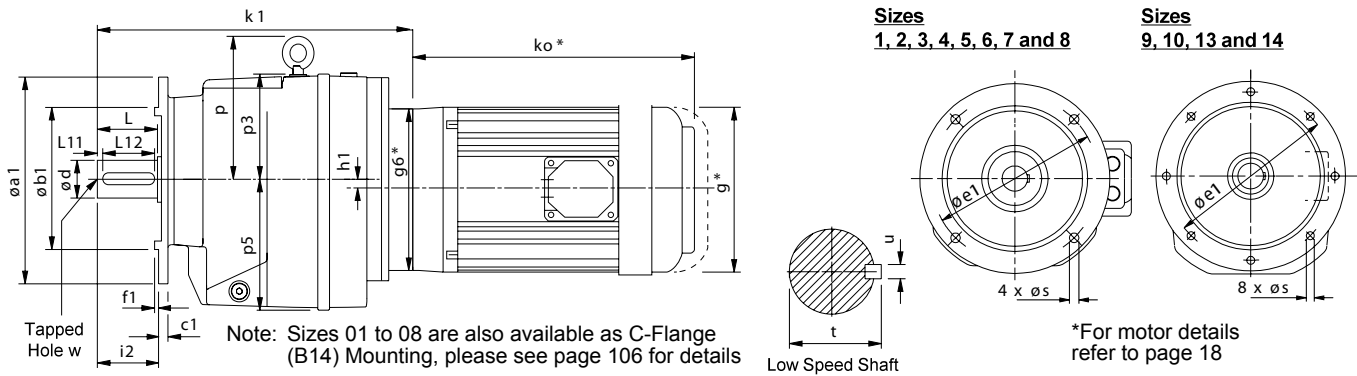

all parallel keys are to DIN 6885

Size	Øa1	Øb1	c1	Øe1	f1	h1	i2	p	p3	p5	s	Low Speed Shaft						
												d	L	L11	L12	t	u	w
M0132	120	80	9	100	3	-	40	-	74	76	9	20 k6	40	4	32	22.5	6	M6 x 1 16 deep
	140	95	9	115	3		40				9							
	160	110	10	130	3.5		40				9							
	200	130	10	165	3.5		40				11							
M0232	120	80	10	100	3	-	50	-	90	91	6.6	25 k6	50	4	40	28	8	M10 x 1.5 16 deep
	140	95	10	115	3		50				9							
	160	110	10	130	3.5		50				9							
	200	130	10	165	3.5		50				11							
M0332	120	80	10	100	3	-	50	-	90	91	6.6	25 k6	50	4	40	28	8	M10 x 1.5 16 deep
	140	95	10	115	3		50				9							
	160	110	10	130	3.5		50				9							
	200	130	10	165	3.5		50				11							
M0432	140	95	11	115	3	-	60	-	93	115	9	30 k6	60	4	50	33	8	M10 x 1.5 16 deep
	160	110	11	130	3.5		60				9							
	200	130	11	165	3.5		60				11							
	250	180	11	215	4		60				13.5							
M0532	140	95	11	115	3	-	70	-	93	115	9	35 k6	70	7	60	38	10	M12 x 1.75 28 deep
	160	110	11	130	3.5		70				9							
	200	130	11	165	3.5		70				11							
	250	180	11	215	4		70				13.5							
M0632	200	130	11	165	4	14.5	70	116	84	130	11	35 k6	70	7	60	38	10	M12 x 1.75 28 deep
	250	180	11	215	4		70				13.5							
	300	230	11	265	4		70				13.5							
M0732	200	130	11	165	3.5	-	80	155	110	140	11	40 k6	80	5	70	43	12	M16 x 2.0 36 deep
	250	180	11	215	4		80				13.5							
	300	230	11	265	4		80				13.5							
M0832	300	230	17	265	4	-	100	180	130	182	13.5	50 k6	100	10	80	53.5	14	M16 x 2.0 36 deep
	350	250	17	300	5		100				17.5							
M0931	450	350	18	400	5	-	140	198	-	230	18	60 m6	120	10	100	64	18	M20 x 2.5 42 deep
M1031	450	350	22	400	5	-	140	245	-	260	18	70 m6	140	15	110	74.5	20	M20 x 2.5 42 deep
M1331	550	450	25	500	5	-	170	288	-	278	18	90 m6	170	15	140	95	25	M24 x 3.0 50 deep
M1431	550	450	25	500	5	-	210	320	-	318	18	100 m6	210	15	180	106	28	M24 x 3.0 50 deep

MOTOR FRAME SIZE	M0132	M0232	M0332	M0432	M0532	M0632	M0732	M0832	M0931	M1031	M1331	M1431
	K1	K1	K1	K1	K1	K1	K1	K1	K1	K1	K1	K1
63	224	253	253	300	310	331	353	-	-	-	-	-
71	228	257	257	304	314	335	359	-	-	-	-	-
80	241	270	270	317	327	348	377	462	549	647	-	-
90	251	280	280	327	337	358	387	472	549	647	-	-
100	259	288	288	335	345	366	414	484	555	653	779	904
112	259	288	288	335	345	366	414	484	555	653	779	904
132	-	-	-	-	-	-	414	506	-	653	779	904
160	-	-	-	-	-	-	-	-	-	688	772	897
180	-	-	-	-	-	-	-	-	-	688	772	897
200	-	-	-	-	-	-	-	-	-	688	772	897
225	-	-	-	-	-	-	-	-	-	715	799	924
250	-	-	-	-	-	-	-	-	-	-	971	1096
280	-	-	-	-	-	-	-	-	-	-	971	1096

SERIES M

DIMENSIONS - QUADRUPLE REDUCTION FLANGE MOUNT

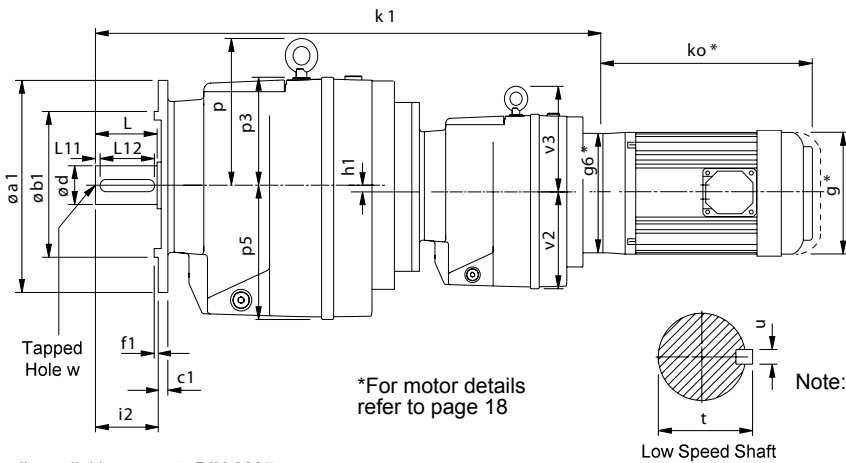

Sizes
3, 4, 5, 6, 7 and 8

Sizes
9, 10, 13 and 14

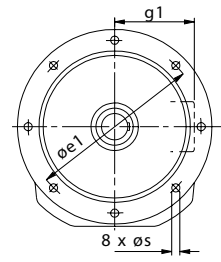
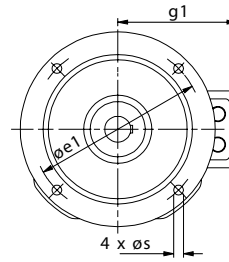

Note: Sizes 03 to 08 are also available as C-Flange (B14) Mounting, please see page 106 for details

all parallel keys are to DIN 6885

Size	Øa1	Øb1	c1	Øe1	f1	h1	i2	p	p3	p5	s	v2	v3	Low Speed Shaft						
														d	L	L11	L12	t	u	w
M0342	120	80	10	100	3	-	50	-	89	91	6.6	76	-	25 k6	50	4	40	28	8	M10 x 1.5 22 deep
	140	95	10	115	3		50				9									
	160	110	10	130	3.5		50				9									
	200	130	10	165	3.5		50				11									
M0442	140	95	11	115	3	-	60	-	91	115	9	91	-	30 k6	60	4	50	33	8	M10 x 1.5 22 deep
	160	110	11	130	3.5		60				9									
	200	130	11	165	3.5		60				11									
	250	180	11	215	4		60				13.5									
M0542	140	95	11	115	3	-	70	-	91	115	9	91	-	35 k6	70	7	60	38	10	M12 x 1.75 28 deep
	160	110	11	130	3.5		70				9									
	200	130	11	165	3.5		70				11									
	250	180	11	215	4		70				13.5									
M0642	200	130	11	165	4	14.5	70	113	81	130	11	91	-	35 k6	70	7	60	38	10	M12 x 1.75 28 deep
	250	180	11	215	4		70				13.5									
	300	230	11	265	4		70				13.5									
M0742	200	130	11	165	3.5	-	80	152	107	140	11	91	-	40 k6	80	5	70	43	12	M16 x 2.0 36 deep
	250	180	11	215	4		80				13.5									
	300	230	11	265	4		80				13.5									
M0842	300	230	17	265	4	-	100	175	125	182	13.5	115	-	50 k6	100	10	80	53.5	14	M16 x 2.0 36 deep
	350	250	17	300	5		100				17.5									
M0941	450	350	18	400	5	-	140	198	-	230	18	140	-	60 m6	120	10	100	64	18	M20 x 2.5 42 deep
M1041	450	350	22	400	5	-	140	245	-	260	18	140	155	70 m6	140	15	110	74.5	20	M20 x 2.5 42 deep
M1341	550	450	25	500	5	-	170	288	-	278	18	140	155	90 m6	170	15	140	95	25	M20 x 3.0 50 deep
M1441	550	450	25	500	5	-	210	320	-	318	18	140	155	100 m6	210	15	180	106	28	M20 x 3.0 50 deep

MOTOR FRAME SIZE	M0342	M0442	M0542	M0642	M0742	M0842	M0941	M1041	M1341	M1441
	K1	K1	K1	K1	K1	K1	K1	K1	K1	K1
63	426	494	504	525	562	652	733	-	-	-
71	430	498	508	529	566	658	739	-	-	-
80	443	511	521	542	579	676	757	878	999	1114
90	453	521	531	552	589	686	767	888	1009	1124
100	-	-	-	-	-	713	794	900	1021	1136
112	-	-	-	-	-	713	794	900	1021	1136
132	-	-	-	-	-	713	794	922	1043	1158
160	-	-	-	-	-	-	-	930	1051	1166

SERIES M

DIMENSIONS - QUINTUPLE REDUCTION FLANGE MOUNT

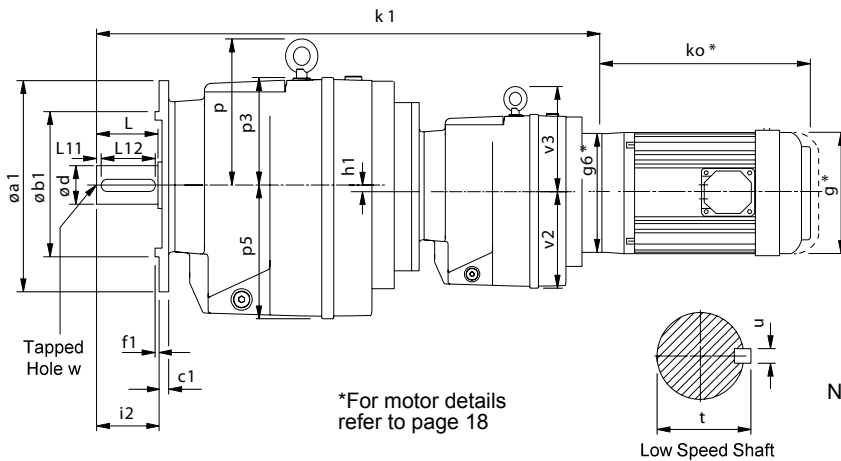

Sizes
3, 4, 5, 6, 7 and 8

Sizes
9, 10, 13 and 14

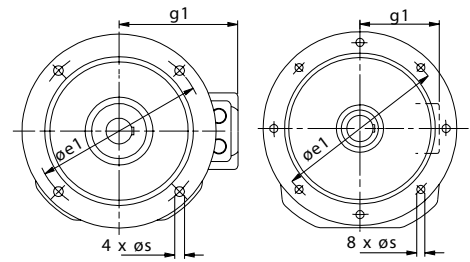

Note: Sizes 03 to 08 are also available as C-Flange (B14) Mounting, please see page 106 for details

all parallel keys are to DIN 6885

Size	$\varnothing a1$	$\varnothing b1$	c1	$\varnothing e1$	f1	h1	i2	p	p3	p5	s	v2	v3	Low Speed Shaft						
														d	L	L11	L12	t	u	w
M0352	120	80	10	100	3	-	50	-	89	91	6.6	76	-	25 k6	50	4	40	28	8	M10 x 1.5 22 deep
	140	95	10	115	3		50				9									
	160	110	10	130	3.5		50				9									
	200	130	10	165	3.5		50				11									
M0452	140	95	11	115	3	-	60	-	91	115	9	91	-	30 k6	60	4	50	33	8	M10 x 1.5 22 deep
	160	110	11	130	3.5		60				9									
	200	130	11	165	3.5		60				11									
	250	180	11	215	4		60				13.5									
M0552	140	95	11	115	3	-	70	-	91	115	9	91	-	35 k6	70	7	60	38	10	M12 x 1.75 28 deep
	160	110	11	130	3.5		70				9									
	200	130	11	165	3.5		70				11									
	250	180	11	215	4		70				13.5									
M0652	200	130	11	165	4	14.5	70	113	81	130	11	91	-	35 k6	70	7	60	38	10	M12 x 1.75 28 deep
	250	180	11	215	4		70				13.5									
	300	230	11	265	4		70				13.5									
M0752	200	130	11	165	3.5	-	80	152	107	140	11	91	-	40 k6	80	5	70	43	12	M16 x 2.0 36 deep
	250	180	11	215	4		80				13.5									
	300	230	11	265	4		80				13.5									
M0852	300	230	17	265	4	-	100	175	125	182	13.5	115	-	50 k6	100	10	80	53.5	14	M16 x 2.0 36 deep
	350	250	17	300	5		100				17.5									
M0951	450	350	18	400	5	-	140	198	-	230	18	115	-	60 m6	120	10	100	64	18	M20 x 2.5 42 deep
M1051	450	350	22	400	5	-	140	245	-	260	18	140	155	70 m6	140	15	110	74.5	20	M20 x 2.5 42 deep
M1351	550	450	25	500	5	-	170	288	-	278	18	140	155	90 m6	170	15	140	95	25	M20 x 3.0 50 deep
M1451	550	450	25	500	5	-	210	320	-	318	18	140	155	100 m6	210	15	180	106	28	M20 x 3.0 50 deep

MOTOR FRAME SIZE	M0352	M0452	M0552	M0652	M0752	M0852	M0951	M1051	M1351	M1451
	K1	K1	K1	K1	K1	K1	K1	K1	K1	K1
63	441	507	517	538	575	682	763	869	990	1105
71	445	511	521	542	579	686	767	875	996	1111
80	458	524	534	555	592	699	780	893	1014	1129
90	468	534	544	565	602	709	790	903	1024	1139
100	-	-	-	-	-	-	-	930	1051	1166
112	-	-	-	-	-	-	-	930	1051	1166

SERIES M

MOTORISED BACKSTOP MODULE

Motorised backstop modules can be fitted between the gear unit and motor. The backstop device incorporates high quality centrifugal lift off sprags which are wear free above the lift off speed (n min).

To ensure correct operation motor speed must exceed lift off speed.

Suitable for ambient temperature -40°C to + 50°C

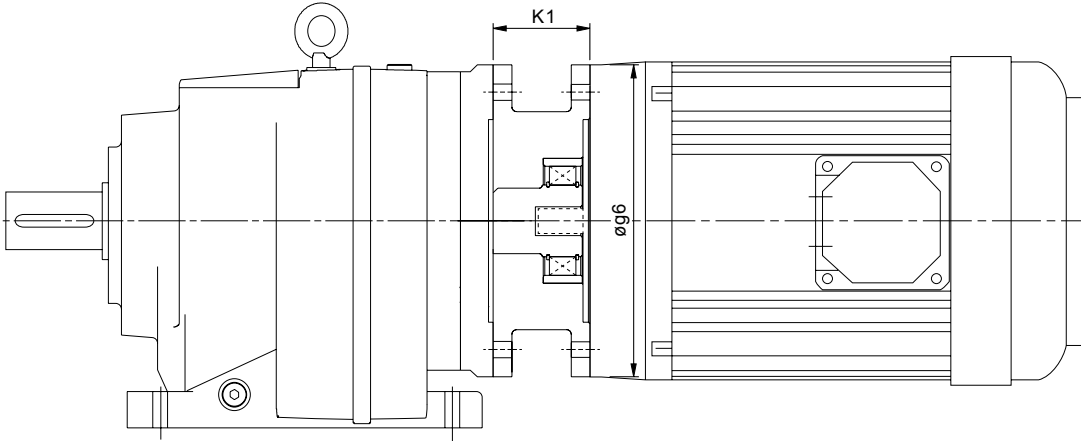

Warning

Removal of motor or backstop will release the drive. Ensure all driven machinery is secure prior to any maintenance work

IEC B5 FLANGE

Motor Frame Size	Lift off Speed ('n' min) (rev/min)	Rated Locking Torque ('T max') (at motor) (Nm)	øg6	K1
100	670	170	250	70
112	670	170	250	70
132	620	940	300	95
160	620	940	350	130
180	620	940	350	130
200	550	1260	400	130

NEMA C FLANGE

Motor Frame Size	Lift off Speed ('n' min) (rev/min)	Rated Locking Torque ('T max') (at motor) (Nm)	øg6	K1
182TC / 184TC	670	300	228	95.25
213TC / 215 TC	670	300	228	95.25
254TC / 256TC	620	940	228	120.65
284TC / 286TC	620	940	280	136.5
324TC / 326TC	550	1260	330	152.4

When a backstop module is fitted dimension K1 should be added to the overall length of the geared motor assembly.

Rotation of outputshaft must be specified when ordering as viewed from the outputshaft end (as shown in the diagram) see page 20 for column 20 entry

CW	-	Free Rotation	-	Clockwise
		Locked	-	Anticlockwise
AC	-	Free Rotation	-	Anticlockwise
		Locked	-	Clockwise

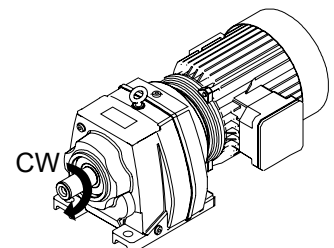

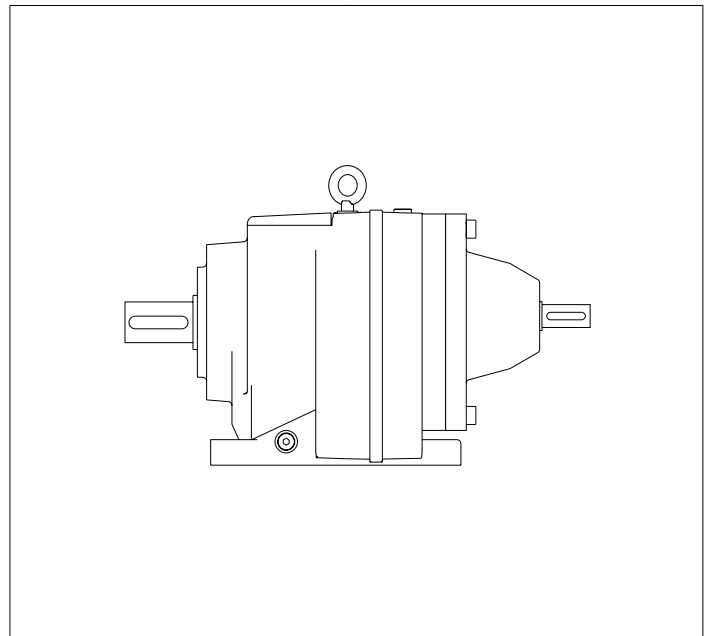

REDUCER
SERIES M

SERIES M

OVERHUNG & AXIAL LOADS (NEWTONS) ON SHAFTS

Maximum permissible overhung loads

When a sprocket, gear etc. is mounted on the shaft a calculation, as below, must be made to determine the overhung load on the shaft, and the results compared to the maximum permissible overhung loads tabulated. Overhung loads can be reduced by increasing the diameter of the sprocket, gear, etc. If the maximum permissible overhung load is exceeded, the sprocket, gear, etc. should be mounted on a separate shaft, flexibly coupled and supported in its own bearings, or the gear unit shaft should be extended to run in an outboard bearing. Alternatively, a larger gear is often a less expensive solution.

Permissible overhung loads vary according to the direction of rotation. The values tabulated are for the most unfavourable direction with the unit transmitting full rated power and the load P applied midway along the shaft extension. Hence they can sometimes be increased for a more favourable direction of rotation, or if the power transmitted is less than the rated capacity of the gear unit, or if the load is applied nearer to the gear unit case. Refer to our Application Engineers for further details. In any event, the sprocket, gear etc. should be positioned as close as possible to the gear unit case in order to reduce bearing loads and shaft stresses, and to prolong life.

All units will accept 100% momentary overload on stated capacities.

Overhung load (Newtons)

$$P = \frac{\text{kW} \times 9,500,000 \times K}{N \times R}$$

where

- P = equivalent overhung load (Newtons)
 kW = power transmitted by the shaft (kilowatts)
 N = speed of shaft (rev/min)
 R = pitch radius of sprocket, etc. (mm)
 K = factor

Overhung member

Overhung member	K (factor)
Chain sprocket*	1.00
Spur or helical pinion	1.25
Vee belt sheave	1.50
Flat belt pulley	2.00

* If multistrand chain drives are equally loaded and the outer strand is further than dimension Fra output or Frb input, refer to our Application Engineers.

Note: 1 Newton = 0.101972 kp = 0.227809 lbf.

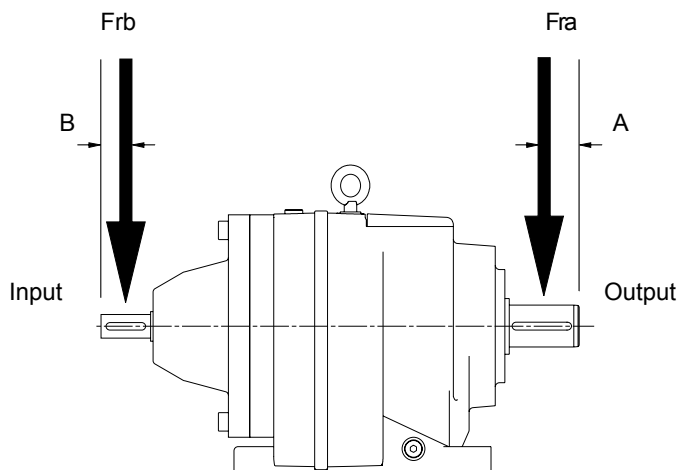

Distance midway along the shaft extension

Size of unit	No. of Reductions	Dimension A (mm)	Dimension B (mm)
M01	2 - 3	20	20
M02	2 - 3	25	20
M03	2 - 5	25	20
M04	2 - 5	30	20
M05	2 - 5	35	20
M06	2 - 5	35	20
M07	2	40	25
	3	40	20
	4 - 5	40	20
M08	2	50	30
	3	50	25
	4 - 5	50	20
M09	2	60	40
	3	60	30
	4 - 5	60	20
M10	2	70	55
	3	70	40
	4 - 5	70	25
M13	2 - 3	85	55
	4	85	25
	5	85	20
M14	2 - 3	105	55
	4	105	25
	5	105	20

SERIES M

OVERHUNG & AXIAL LOADS (NEWTONS) ON SHAFTS

Inputshaft Overhung Loads, Frb (Kn) 1450 rpm

Two, Three, Four and Five Stage Units

	M01	M02	M03	M04	M05	M06	M07	M08	M09	M10	M13	M14
2 Stage	1.5	1.65	1.56	1.2	1.1	0.9	1.65	1.5	1.5	2.55	6.9	7.1
3 stage	1.65	1.75	1.75	1.5	1.5	1.5	1.8	2.25	3.5	4.2	12	12
4 Stage	-	-	1.5	1.5	1.5	1.5	1.5	1.75	1.75	2.25	2.25	2.25
5 Stage	-	-	1.5	1.5	1.5	1.5	1.5	1.75	1.75	2.25	2.25	2.25

For output overhung load Fra consult ratings tables

Axial Thrust Capacities (Newtons)

No check or calculation is required for axial loads (F_A) towards or away from the unit up to 50% of the permissible overhung load. If the axial thrust considerably exceeds these values or if there is a combination of axial thrust loads and overhung loads please contact our Application Engineers.

SERIES M

TRIPLE REDUCTION RATINGS SIZES M01 - M04

Pm - Input Power (kW) *N2* - Output Speed (rpm)
M2 - Output Torque (Nm) *fra* - Overhung Load (kN)
i - Exact Ratio (:1)

TRIPLE REDUCTION

Column Entry	Input Speed N1 (rpm)	M0132					M0232					M0332					M0432				
		N2 (rpm)	i (:1)	M2 (Nm)	Pm (kW)	fra (kN)	N2 (rpm)	i (:1)	M2 (Nm)	Pm (kW)	fra (kN)	N2 (rpm)	i (:1)	M2 (Nm)	Pm (kW)	fra (kN)	N2 (rpm)	i (:1)	M2 (Nm)	Pm (kW)	fra (kN)
6 7 8	2900	50	58.461	90	0.5	1.50	51	57.027	159	0.89	4.00	51	57.027	209	1.17	2.80	50	58.382	287	1.57	6.70
	1450	25		90	0.25	1.90	25		160	0.45	4.00	25		209	0.58	3.15	25		338	0.92	7.20
	960	16		90	0.16	1.90	17		160	0.3	4.00	17		209	0.39	3.15	16		338	0.61	7.20
	725	12		90	0.12	1.90	13		160	0.22	4.00	13		209	0.29	3.15	12		338	0.46	7.20
6 3	2900	45	64.453	90	0.45	1.50	46	62.872	160	0.81	4.00	46	62.872	209	1.06	2.90	45	64.290	293	1.46	7.10
	1450	22		90	0.22	1.90	23		160	0.41	4.00	23		209	0.53	3.15	23		338	0.84	7.20
	960	15		90	0.15	1.90	15		160	0.27	4.00	15		209	0.35	3.15	15		338	0.55	7.20
	725	11		90	0.11	1.90	12		160	0.2	4.00	12		209	0.26	3.15	11		338	0.42	7.20
7 1	2900	41	70.933	90	0.41	1.60	42	69.193	160	0.74	4.00	42	69.193	209	0.97	3.00	39	73.950	302	1.31	7.20
	1450	20		90	0.2	1.90	21		160	0.37	4.00	21		209	0.48	3.15	20		338	0.73	7.20
	960	14		90	0.13	1.90	14		160	0.24	4.00	14		209	0.32	3.15	13		338	0.48	7.20
	725	10		90	0.1	1.90	10		160	0.18	4.00	10		209	0.24	3.15	9.8		338	0.36	7.20
8 0	2900	35	83.104	90	0.35	1.70	36	81.066	160	0.63	4.00	36	81.066	209	0.82	3.10	36	80.397	307	1.22	7.20
	1450	17		90	0.17	1.90	18		160	0.31	4.00	18		209	0.41	3.15	18		338	0.67	7.20
	960	12		90	0.12	1.90	12		160	0.21	4.00	12		209	0.27	3.15	12		338	0.44	7.20
	725	8.7		90	0.09	1.90	8.9		160	0.16	4.00	8.9		209	0.2	3.15	9.0		338	0.33	7.20
1 0 0	2900	29	99.702	90	0.29	1.90	30	97.257	160	0.53	4.00	30	97.257	209	0.69	3.15	30	96.516	324	1.07	7.20
	1450	15		90	0.14	1.90	15		160	0.26	4.00	15		209	0.34	3.15	15		338	0.56	7.20
	960	9.6		90	0.1	1.90	9.9		160	0.17	4.00	9.9		209	0.23	3.15	9.9		338	0.37	7.20
	725	7.3		90	0.07	1.90	7.5		160	0.13	4.00	7.5		209	0.17	3.15	7.5		338	0.28	7.20
1 1 2	2900	25	116.22	90	0.25	1.90	26	113.37	160	0.45	4.00	26	113.37	209	0.59	3.15	25	115.819	338	0.93	7.20
	1450	12		90	0.12	1.90	13		160	0.23	4.00	13		209	0.29	3.15	13		338	0.47	7.20
	960	8.3		90	0.08	1.90	8.5		160	0.15	4.00	8.5		209	0.19	3.15	8.3		338	0.31	7.20
	725	6.2		90	0.06	1.90	6.4		160	0.11	4.00	6.4		209	0.15	3.15	6.3		338	0.23	7.20
1 2 5	2900	22	129.134	90	0.22	1.90	23	125.967	160	0.41	4.00	23	125.967	209	0.53	3.15	22	130.500	338	0.83	7.20
	1450	11		90	0.11	1.90	12		160	0.2	4.00	12		209	0.27	3.15	11		338	0.41	7.20
	960	7.4		90	0.07	1.90	7.6		160	0.14	4.00	7.6		209	0.18	3.15	7.4		338	0.27	7.20
	725	5.6		90	0.06	1.90	5.6		160	0.1	4.00	5.6		209	0.13	3.15	5.6		338	0.21	7.20
1 6 0	2900	19	155.506	90	0.19	1.90	19	151.692	160	0.34	4.00	19	151.692	209	0.44	3.15	19	151.706	338	0.71	7.20
	1450	9.3		90	0.09	1.90	9.6		160	0.17	4.00	10		209	0.22	3.15	9.6		338	0.36	7.20
	960	6.2		90	0.06	1.90	6.3		160	0.11	4.00	6.3		209	0.15	3.15	6.3		338	0.23	7.20
	725	4.7		90	0.05	1.90	4.8		160	0.08	4.00	4.8		209	0.11	3.15	4.8		338	0.18	7.20
1 8 0	2900	16	178.241	90	0.16	1.90	17	173.87	160	0.29	4.00	17	173.87	209	0.39	3.15	17	172.188	338	0.63	7.20
	1450	8.1		90	0.08	1.90	8.3		160	0.15	4.00	8.3		209	0.19	3.15	8.4		338	0.31	7.20
	960	5.4		90	0.05	1.90	5.5		160	0.1	4.00	5.5		209	0.13	3.15	5.6		338	0.21	7.20
	725	4.1		90	0.04	1.90	4.2		160	0.07	4.00	4.2		209	0.1	3.15	4.2		338	0.16	7.20
2 0 0	2900	14	202.567	90	0.14	1.90	15	197.599	160	0.26	4.00	15	197.599	209	0.34	3.15	15	195.75	338	0.55	7.20
	1450	7.2		90	0.07	1.90	7.3		160	0.13	4.00	7.3		209	0.17	3.15	7.7		338	0.28	7.20
	960	4.7		90	0.05	1.90	4.9		160	0.09	4.00	4.9		209	0.11	3.15	4.9		338	0.18	7.20
	725	3.6		90	0.04	1.90	3.7		160	0.06	4.00	3.7		209	0.09	3.15	3.7		338	0.14	7.20

SERIES M

TRIPLE REDUCTION RATINGS SIZES M05 - M08

Pm - Input Power (kW) *N2* - Output Speed (rpm)
M2 - Output Torque (Nm) *fra* - Overhung Load (kN)
i - Exact Ratio (:1)

TRIPLE REDUCTION

Column Entry	Input Speed N1 (rpm)	M0532					M0632					M0732					M0832					
		N2 (rpm)	i (:1)	M2 (Nm)	Pm (kW)	fra (kN)	N2 (rpm)	i (:1)	M2 (Nm)	Pm (kW)	fra (kN)	N2 (rpm)	i (:1)	M2 (Nm)	Pm (kW)	fra (kN)	N2 (rpm)	i (:1)	M2 (Nm)	Pm (kW)	fra (kN)	
5 6 .	2900	50	58.382	443	2.42	4.20					49	58.950	640	3.47	4.50	48	60.330	1300	6.94	9.25		
	1450	25		450	1.22	7.20					25		754	2.03	8.10	24		1600	4.23	16.20		
	960	16		450	0.81	7.20					16		865	1.54	9.20	16		1700	2.96	16.20		
	725	12		450	0.61	7.20					12		868	1.17	9.20	12		1700	2.23	16.20		
6 3 .	2900	45	64.290	431	2.14	4.50	40	72.282	549	2.42	7.20	46	62.834	649	3.3	4.65	44	66.02	1340	6.5	9.50	
	1450	23		450	1.11	7.20	20		626	1.38	7.20	23		770	1.95	9.20	22		1650	3.97	16.20	
	960	15		450	0.74	7.20	13		626	0.91	7.20	15		868	1.45	9.20	15		1700	2.71	16.20	
	725	11		450	0.56	7.20	10		626	0.69	7.20	12		868	1.09	9.20	11		1700	2.04	16.20	
7 1 .	2900	39	73.950	443	1.91	5.00	36	79.598	534	2.14	7.20	39	74.467	673	2.88	5.10	39	74.691	1390	5.96	10.00	
	1450	20		450	0.97	7.20	18		623	1.24	7.20	19		815	1.74	9.20	19		1700	3.62	16.20	
	960	13		450	0.64	7.20	12		626	0.82	7.20	13		868	1.22	9.20	13		1700	2.39	16.20	
	725	10		450	0.48	7.20	9.1		626	0.62	7.20	10		868	0.92	9.20	10		1700	1.8	16.20	
8 0 .	2900	36	80.397	450	1.78	5.60	32	91.557	549	1.91	7.20	36	79.507	682	2.74	6.30	34	84.31	1440	5.47	12.30	
	1450	18		450	0.89	7.20	16		626	1.09	7.20	18		833	1.67	9.20	17		1700	3.21	16.20	
	960	12		450	0.59	7.20	10.4		626	0.72	7.20	12		868	1.15	9.20	11		1700	2.12	16.20	
	725	9.0		450	0.44	7.20	7.8		626	0.54	7.20	9		868	0.87	9.20	9		1700	1.6	16.20	
1 0 0	2900	30	96.516	450	1.49	6.30	29	99.54	558	1.79	7.20	29	98.661	714	2.31	7.40	28	102.204	1520	4.78	14.00	
	1450	15		450	0.74	7.20	15		626	1	7.20	15		868	1.4	9.20	14		1700	2.65	16.20	
	960	9.9		450	0.49	7.20	9.6		626	0.66	7.20	10		868	0.93	9.20	9		1700	1.75	16.20	
	725	7.5		450	0.37	7.20	7.3		626	0.5	7.20	7		868	0.7	9.20	7		1700	1.32	16.20	
1 1 2	2900	25	115.819	450	1.24	7.20	24	119.496	585	1.56	7.20	25	116.342	751	2.06	9.20	24	119.188	1600	4.29	16.20	
	1450	13		450	0.62	7.20	12		626	0.83	7.20	12		868	1.19	9.20	12		1700	2.27	16.20	
	960	8.3		450	0.41	7.20	8.0		626	0.55	7.20	8		868	0.79	9.20	8		1700	1.5	16.20	
	725	6.3		450	0.31	7.20	6.1		626	0.42	7.20	6		874	0.6	9.20	6		1700	1.13	16.20	
1 2 5	2900	22	130.500	450	1.1	7.20	20	143.395	613	1.37	7.20	23	127.392	774	1.94	9.20	22	130.924	1640	4.02	16.20	
	1450	11		450	0.55	7.20	10.1		626	0.7	7.20	11		868	1.09	9.20	11		1700	2.07	16.20	
	960	7.4		450	0.36	7.20	6.7		626	0.46	7.20	8		868	0.72	9.20	7		1700	1.37	16.20	
	725	5.6		450	0.28	7.20	5.1		626	0.35	7.20	6		883	0.55	9.20	6		1700	1.03	16.20	
1 6 0	2900	19	151.706	450	0.95	7.20	18	161.571	626	1.24	7.20	19	156.123	828	1.7	9.20	18	160.446	1700	3.39	16.20	
	1450	9.9		450	0.47	7.20	9.0		626	0.62	7.20	9		868	0.89	9.20	9		1700	1.69	16.20	
	960	6.3		450	0.31	7.20	5.9		626	0.41	7.20	6		875	0.59	9.20	6		1700	1.12	16.20	
	725	4.8		450	0.24	7.20	4.5		626	0.31	7.20	5		888	0.45	9.20	5		1720	0.85	16.20	
1 8 0	2900	17	172.188	450	0.83	7.20	15	187.827	626	1.06	7.20	17	174.012	858	1.58	9.20	17	175.207	1700	3.1	16.20	
	1450	8.4		450	0.42	7.20	7.7		626	0.53	7.20	8		868	0.8	9.20	8		1700	1.55	16.20	
	960	5.6		450	0.28	7.20	5.1		626	0.35	7.20	6		886	0.54	9.20	5		1700	1.02	16.20	
	725	4.2		450	0.21	7.20	3.9		626	0.26	7.20	4		888	0.41	9.20	4		1730	0.79	16.20	
2 0 0	2900	15	195.75	450	0.74	7.20	14	213.185	626	0.94	7.20	15	195.154	868	1.43	9.20	14	201.754	1700	2.7	16.20	
	1450	7.4		450	0.37	7.20	6.8		626	0.47	7.20	7		868	0.71	9.20	7		1700	1.35	16.20	
	960	4.9		450	0.24	7.20	4.5		626	0.31	7.20	5		888	0.48	9.20	5		1710	0.9	16.20	
	725	3.7		450	0.18	7.20	3.4		626	0.23	7.20	4		888	0.36	9.20	4		1750	0.69	16.20	
2 2 5	2900						12	242.36	626	0.83	7.20											
	1450						6.0		626	0.41	7.20											
	960						4.0		626	0.27	7.20											
	725						3.0		626	0.21	7.20											

SERIES M

QUINTUPLE REDUCTION RATINGS

SIZES M03 - M07

Pm - Input Power (kW) *N2* - Output Speed (rpm)
M2 - Output Torque (Nm) *fra* - Overhung Load (kN)
i - Exact Ratio (:1)

QUINTUPLE REDUCTION

Column Entry	Input Speed N1 (rpm)	M0352					M0452					M0552					M0652					M0752				
		N2 (rpm)	i (:1)	M2 (Nm)	Pm (kW)	fra (kN)	N2 (rpm)	i (:1)	M2 (Nm)	Pm (kW)	fra (kN)	N2 (rpm)	i (:1)	M2 (Nm)	Pm (kW)	fra (kN)	N2 (rpm)	i (:1)	M2 (Nm)	Pm (kW)	fra (kN)	N2 (rpm)	i (:1)	M2 (Nm)	Pm (kW)	fra (kN)
6 7 8	2900	1.102		210	0.026	3.15	1.092		340	0.041	7.20	1.092		450	0.054	7.20	1.095		625	0.075	7.20	1.107		865	0.106	9.20
	1450	0.551	2632	210	0.013	3.15	0.546	2655	340	0.021	7.20	0.546	2655	450	0.027	7.20	0.547	2649	625	0.038	7.20	0.554	2619	865	0.053	9.20
	960	0.365		210	0.009	3.15	0.362		340	0.014	7.20	0.362		450	0.018	7.20	0.362		625	0.025	7.20	0.367		865	0.035	9.20
	725	0.274		210	0.006	3.15	0.271		340	0.010	7.20	0.271		450	0.014	7.20	0.272		625	0.019	7.20	0.275		865	0.026	9.20
3 2 C	2900	0.945		210	0.022	3.15	0.937		340	0.035	7.20	0.937		450	0.046	7.20	0.939		625	0.065	7.20	0.95		865	0.046	9.20
	1450	0.473	3068	210	0.011	3.15	0.468	3095	340	0.018	7.20	0.468	3095	450	0.023	7.20	0.47	3088	625	0.033	7.20	0.475	3053	865	0.046	9.20
	960	0.313		210	0.007	3.15	0.310		340	0.012	7.20	0.31		450	0.016	7.20	0.311		625	0.022	7.20	0.314		865	0.046	9.20
	725	0.235		210	0.005	3.15	0.233		340	0.009	7.20	0.233		450	0.012	7.20	0.233		625	0.016	7.20	0.236		865	0.046	9.20
3 6 C	2900	0.788		210	0.018	3.15	0.795		340	0.030	7.20	0.795		450	0.039	7.20	0.757		625	0.052	7.20	0.796		865	0.076	9.20
	1450	0.394	3681	210	0.009	3.15	0.397	3650	340	0.015	7.20	0.397	3650	450	0.02	7.20	0.378	3832	625	0.026	7.20	0.398	3641	865	0.038	9.20
	960	0.261		210	0.006	3.15	0.263		340	0.010	7.20	0.263		450	0.013	7.20	0.251		625	0.017	7.20	0.264		865	0.025	9.20
	725	0.196		210	0.005	3.15	0.197		340	0.007	7.20	0.197		450	0.01	7.20	0.188		625	0.013	7.20	0.198		865	0.019	9.20
4 0 C	2900	0.709		210	0.016	3.15	0.715		340	0.027	7.20	0.715		450	0.035	7.20	0.681		625	0.047	7.20	0.717		865	0.068	9.20
	1450	0.354	4091	210	0.008	3.15	0.358	4055	340	0.014	7.20	0.358	4055	450	0.018	7.20	0.341	4258	625	0.024	7.20	0.358	4046	865	0.035	9.20
	960	0.235		210	0.005	3.15	0.237		340	0.009	7.20	0.237		450	0.012	7.20	0.225		625	0.016	7.20	0.237		865	0.023	9.20
	725	0.176		210	0.004	3.15	0.178		340	0.007	7.20	0.178		450	0.009	7.20	0.169		625	0.012	7.20	0.178		865	0.017	9.20
4 6 C	2900	0.629		210	0.015	3.15	0.653		340	0.024	7.20	0.653		450	0.032	7.20	0.578		625	0.04	7.20	0.655		865	0.062	9.20
	1450	0.315	4609	210	0.007	3.15	0.327	4440	340	0.012	7.20	0.327	4440	450	0.016	7.20	0.289	5021	625	0.02	7.20	0.327	4431	865	0.032	9.20
	960	0.208		210	0.005	3.15	0.216		340	0.008	7.20	0.216		450	0.011	7.20	0.191		625	0.013	7.20	0.217		865	0.021	9.20
	725	0.156		210	0.004	3.15	0.162		340	0.006	7.20	0.162		450	0.008	7.20	0.143		625	0.01	7.20	0.163		865	0.016	9.20
5 5 C	2900	0.522		210	0.012	3.15	0.542		340	0.020	7.20	0.542		450	0.027	7.20	0.48		625	0.033	7.20	0.544		865	0.052	9.20
	1450	0.261	5550	210	0.006	3.15	0.271	5347	340	0.010	7.20	0.271	5347	450	0.014	7.20	0.24	6046	625	0.017	7.20	0.272	5335	865	0.026	9.20
	960	0.173		210	0.004	3.15	0.180		340	0.007	7.20	0.18		450	0.009	7.20	0.159		625	0.011	7.20	0.18		865	0.017	9.20
	725	0.13		210	0.003	3.15	0.135		340	0.005	7.20	0.135		450	0.007	7.20	0.119		625	0.008	7.20	0.135		865	0.013	9.20
6 5 C	2900	0.449		203	0.01	3.15	0.443		340	0.017	7.20	0.443		450	0.022	7.20	0.438		625	0.03	7.20	0.453		865	0.043	9.20
	1450	0.225	6452	203	0.005	3.15	0.221	6553	340	0.008	7.20	0.221	6553	450	0.011	7.20	0.219	6620	625	0.015	7.20	0.226	6403	865	0.022	9.20
	960	0.149		203	0.003	3.15	0.146		340	0.006	7.20	0.146		450	0.007	7.20	0.145		625	0.01	7.20	0.15		865	0.014	9.20
	725	0.112		203	0.003	3.15	0.110		340	0.004	7.20	0.11		450	0.006	7.20	0.109		625	0.008	7.20	0.112		865	0.011	9.20
7 4 C	2900	0.392		203	0.009	3.15	0.386		340	0.014	7.20	0.386		450	0.019	7.20	0.382		625	0.026	7.20	0.395		865	0.038	9.20
	1450	0.196	7396	203	0.004	3.15	0.193	7511	340	0.007	7.20	0.193	7511	450	0.01	7.20	0.191	7588	625	0.013	7.20	0.198	7339	865	0.019	9.20
	960	0.13		203	0.003	3.15	0.128		340	0.005	7.20	0.128		450	0.006	7.20	0.127		625	0.009	7.20	0.131		865	0.013	9.20
	725	0.097		203	0.002	3.15	0.096		340	0.004	7.20	0.096		450	0.005	7.20	0.095		625	0.007	7.20	0.098		865	0.009	9.20
8 4 C	2900	0.345		203	0.008	3.15	0.346		340	0.013	7.20	0.346		380	0.015	7.20	0.336		625	0.023	7.20	0.343		725	0.027	9.20
	1450	0.173	8394	203	0.004	3.15	0.173	8372	340	0.007	7.20	0.173	8372	380	0.007	7.20	0.168	8624	625	0.012	7.20	0.172	8443	725	0.014	9.20
	960	0.114		203	0.003	3.15	0.115		340	0.004	7.20	0.115		380	0.005	7.20	0.111		625	0.008	7.20	0.114		725	0.009	9.20
	725	0.086		203	0.002	3.15	0.086		340	0.003	7.20	0.086		380	0.004	7.20	0.083		625	0.006	7.20	0.085		725	0.007	9.20
9 5 C	2900	0.304		203	0.007	3.15	0.305		340	0.011	7.20	0.305		380	0.013	7.20	0.312		620	0.021	7.20	0.302		725	0.024	9.20
	1450	0.152	9540	203	0.003	3.15	0.152	9514	340	0.006	7.20	0.152	9514	380	0.006	7.20	0.156	9300	620	0.011	7.20	0.151	9596	725	0.012	9.20
	960	0.101		203	0.002	3.15	0.101		340	0.004	7.20	0.101		380	0.004	7.20	0.103		620	0.007	7.20	0.1		725	0.008	9.20
	725	0.075		203	0.002	3.15	0.076		340	0.003	7.20	0.076		380	0.003	7.20	0.077		620	0.005	7.20	0.075		725	0.006	9.20
1 0 K	2900	0.267		203	0.006	3.15	0.272		270	0.008	7.20	0.272		270	0.008	7.20	0.274		620	0.019	7.20	0.272		725	0.022	9.20
	1450	0.134	10845	203	0.003	3.15	0.136	10670	270	0.004	7.20	0.136	10670	270	0.004	7.20	0.137	10569	620	0.009	7.20	0.136	10662	725	0.011	9.20
	960	0.089		203	0.002	3.15	0.090		270	0.003	7.20	0.09		270	0.003	7.20	0.091		620	0.006	7.20	0.09		725	0.007	9.20
	725	0.066		203	0.002	3.15	0.067		270	0.002	7.20	0.067		270	0.002	7.20	0.068		620	0.005	7.20	0.068		725	0.005	9.20

SERIES M

DIMENSIONS - DOUBLE REDUCTION BASE MOUNT

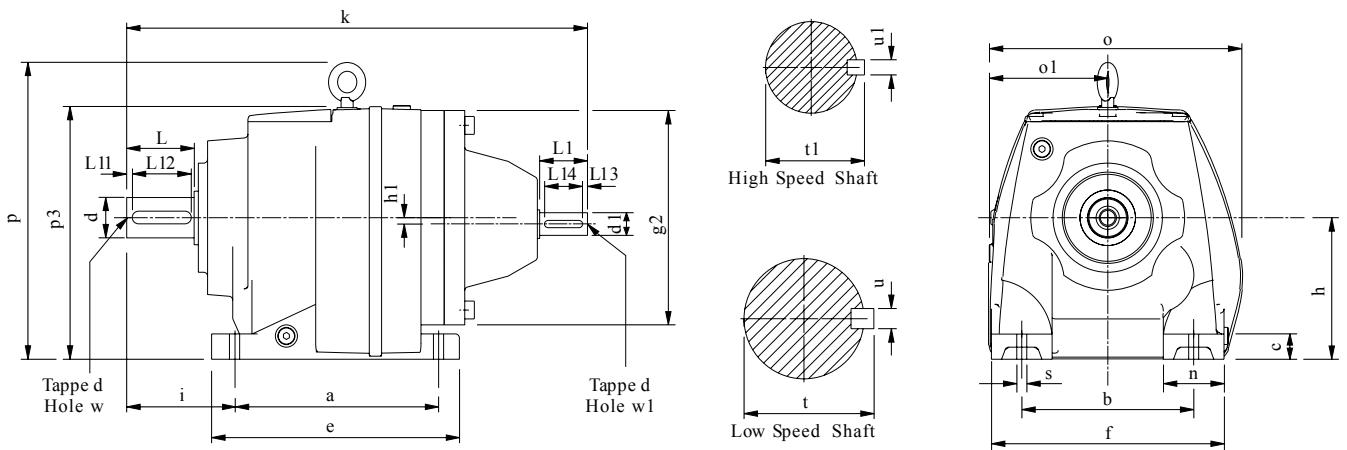

all parallel keys are to DIN 6885

size	a	b	c	e	f	g2	h	h1	i	k	n	o	o1	p	p3	s
M0122	110	110	12	131	135	140	75	-	58	286	25	152	76	-	149	10
M0222	130	110	16	152	145	140	90	-	75	317	35	170	84	-	180	10
M0322	130	110	16	152	145	140	90	-	75	317	35	170	84	-	180	10
M0422	165	135	20	200	190	180	115	-	90	369	55	204	97	-	208	15
M0522	165	135	20	200	190	180	115	-	100	379	55	204	97	-	208	15
M0622	195	150	24	235	210	180	130	14.5	100	400	60	220	110	246	214	15
M0722	205	170	25	245	230	212	140	-	115	440	60	252	119	295	250	19
M0822	260	215	35	310	290	250	180	-	140	555	75	320	167	360	310	19
M0921	310	250	40	365	340	300	225	-	160	660	90	372	200	433	394	23
M1021	370	290	45	440	400	360	250	-	185	782	110	428	225	505	446	27
M1321	410	340	50	490	450	400	265	-	220	907	110	470	242	563	483	34
M1421	500	380	50	590	530	460	300	-	260	1022	150	546	278	630	551	41

SIZE	High Speed shaft							Low Speed shaft						
	d1	L1	L13	L14	t1	u1	w1	d	L	L11	L12	t	u	w
M0122	16 k6	40	4	32	18	5	M5 x 0.8 12 deep	20 k6	40	4	32	22.5	6	M6 x 1 16 deep
M0222	16 k6	40	4	32	18	5	M5 x 0.8 12 deep	25 k6	50	4	40	28	8	M10 x 1.5 22 deep
M0322	16 k6	40	4	32	18	5	M5 x 0.8 12 deep	25 k6	50	4	40	28	8	M10 x 1.5 22 deep
M0422	16 k6	40	4	32	21.5	6	M6 x 1.0 16 deep	30 k6	60	4	50	33	8	M10 x 1.5 22 deep
M0522	16 k6	40	4	32	21.5	6	M6 x 1.0 16 deep	35 k6	70	7	60	38	10	M12 x 1.75 28 deep
M0622	16 k6	40	4	32	21.5	6	M6 x 1.0 16 deep	35 k6	70	7	60	38	10	M12 x 1.75 28 deep
M0722	19 k6	50	5	40	27	8	M8 x 1.25 19 deep	40 k6	80	5	70	43	12	M16 x 2.0 36 deep
M0822	24 k6	60	5	50	31	8	M10 x 1.5 22 deep	50 k6	100	10	80	53.5	14	M16 x 2.0 36 deep
M0921	28 k6	80	5	70	41	10	M12 x 1.75 28 deep	60 m6	120	10	100	64	18	M20 x 2.5 42 deep
M1021	38 k6	110	10	70	45	12	M16 x 2.0 36 deep	70 m6	140	15	110	74.5	20	M20 x 2.5 42 deep
M1321	55 m6	110	10	90	59	16	M20 x 2.5 42 deep	90 m6	170	15	140	95	25	M24 x 3.0 50 deep
M1421	55 m6	110	10	90	59	16	M20 x 2.5 42 deep	100 m6	210	15	180	106	28	M24 x 3.0 50 deep

SERIES M

DIMENSIONS - TRIPLE REDUCTION BASE MOUNT

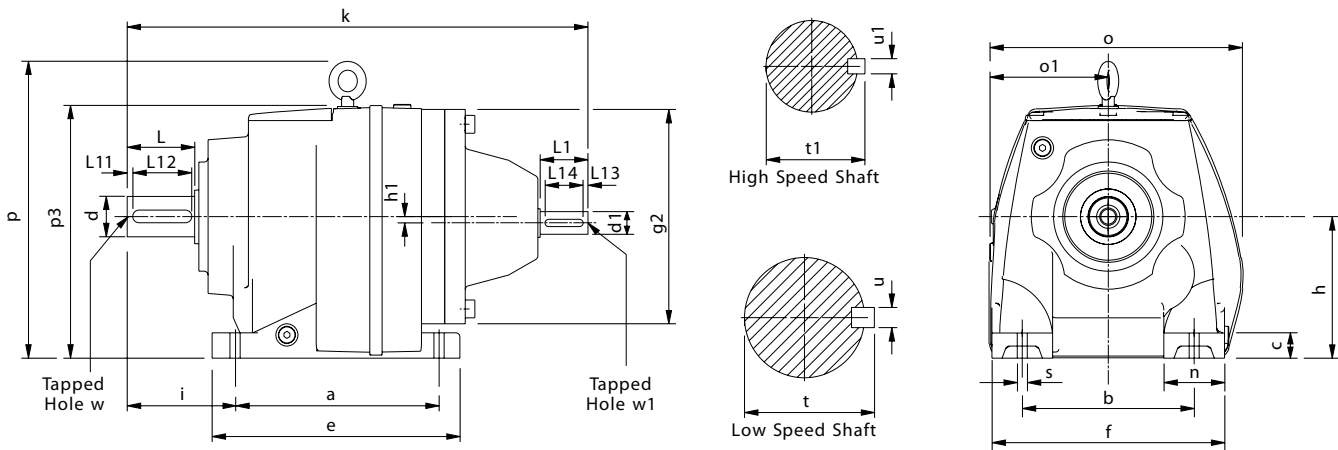

all parallel keys are to DIN 6885

size	a	b	c	e	f	g2	h	h1	i	k	n	o	o1	p	p3	s
M0132	110	110	12	131	135	140	75	-	58	301	25	152	76	-	149	10
M0232	130	110	16	152	145	140	90	-	75	330	35	170	84	-	180	10
M0332	130	110	16	152	145	140	90	-	75	330	35	170	84	-	180	10
M0432	165	135	20	200	190	180	115	-	90	377	55	204	97	-	208	15
M0532	165	135	20	200	190	180	115	-	100	387	55	204	97	-	208	15
M0632	195	150	24	235	210	180	130	14.5	100	408	60	220	110	246	214	15
M0732	205	170	25	245	230	212	140	-	115	452	60	252	119	295	250	19
M0832	260	215	35	310	290	250	180	-	140	540	75	320	167	360	310	19
M0931	310	250	40	365	340	250	225	-	160	662	90	372	200	433	394	23
M1031	370	290	45	440	400	300	250	-	185	784	110	428	225	505	446	27
M1331	410	340	50	490	450	400	265	-	220	969	110	470	242	563	483	34
M1431	500	380	50	590	530	460	300	-	260	1094	150	546	278	630	551	41

SIZE	High Speed shaft							Low Speed shaft						
	d1	L1	L13	L14	t1	u1	w1	d	L	L11	L12	t	u	w
M0132	16 k6	40	4	32	18	5	M5 x 0.8 12 deep	20	40	4	32	22.5	6	M6 x 1.16 deep
M0232	16 k6	40	4	32	18	5	M5 x 0.8 12 deep	25	50	4	40	28	8	M10 x 1.5 22 deep
M0332	16 k6	40	4	32	18	5	M5 x 0.8 12 deep	25	50	4	40	28	8	M10 x 1.5 22 deep
M0432	16 k6	40	4	32	18	5	M5 x 0.8 12 deep	30	60	4	50	33	8	M10 x 1.5 22 deep
M0532	16 k6	40	4	32	18	5	M5 x 0.8 12 deep	35	70	7	60	38	10	M12 x 1.75 28 deep
M0632	16 k6	40	4	32	18	5	M5 x 0.8 12 deep	35	70	7	60	38	10	M12 x 1.75 28 deep
M0732	19 k6	40	4	32	21.5	6	M6 x 1.0 16 deep	40	80	5	70	43	12	M16 x 2.0 36 deep
M0832	24 k6	50	5	40	27	8	M8 x 1.25 19 deep	50	100	10	80	53.5	14	M16 x 2.0 36 deep
M0931	28 k6	60	5	50	31	8	M10 x 1.5 22 deep	60	120	10	100	64	18	M20 x 2.5 42 deep
M1031	38 k6	80	5	70	41	10	M12 x 1.75 28 deep	70	140	15	110	74.5	20	M20 x 2.5 42 deep
M1331	55 m6	110	10	90	59	16	M20 x 2.5 42 deep	90	170	15	140	95	25	M24 x 3.0 50 deep
M1431	55 m6	110	10	90	59	16	M20 x 2.5 42 deep	100	210	15	180	106	28	M24 x 3.0 50 deep

SERIES M

DIMENSIONS - QUADRUPLE REDUCTION BASE MOUNT

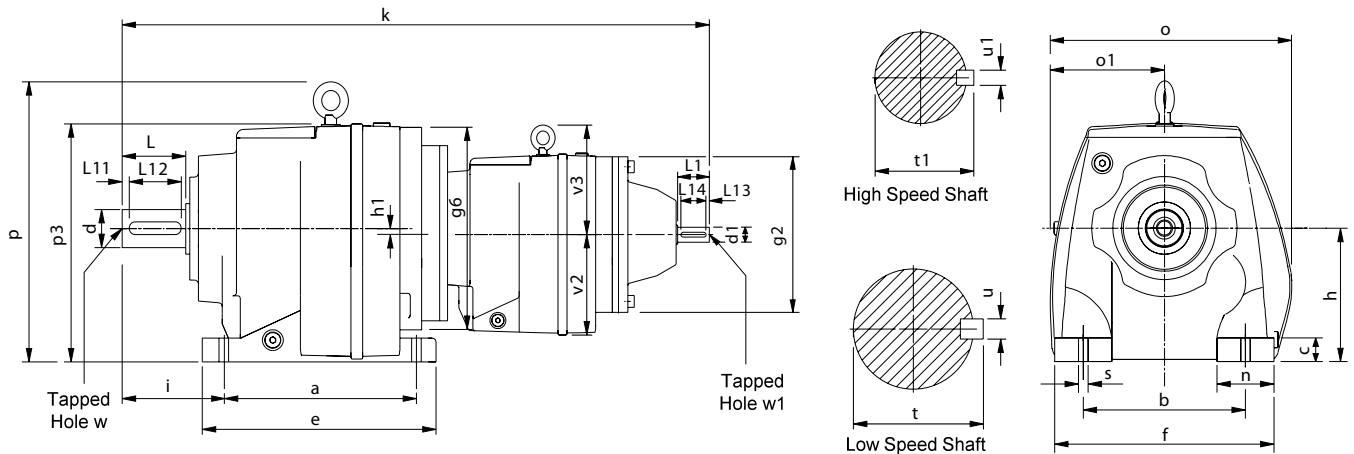

all parallel keys are to DIN 6885

size	a	b	c	e	f	g2	g6	h	h1	i	k	n	o	o1	p	p3	s	v2	v3
M0342	130	110	16	152	145	140	140	90	-	75	503	35	170	84	-	180	10	76	-
M0442	165	135	20	200	190	140	180	115	-	90	571	55	204	97	-	208	15	91	-
M0542	165	135	20	200	190	140	180	115	-	100	581	55	204	97	-	208	15	91	-
M0642	195	150	24	235	210	140	180	130	14.5	100	602	60	220	110	246	214	15	91	-
M0742	205	170	25	245	230	140	212	140	-	115	639	60	252	119	295	250	19	91	-
M0842	260	215	35	310	290	180	250	180	-	140	751	75	320	167	360	310	19	115	-
M0941	310	250	40	365	340	180	250	225	-	160	832	90	372	200	433	394	23	113	-
M1041	370	290	45	440	400	180	300	250	-	185	956	110	428	225	505	446	27	138	155
M1341	410	340	50	490	450	212	350	265	-	220	1077	110	470	242	563	483	34	187	155
M1441	500	380	50	590	530	212	350	300	-	260	1192	150	546	278	630	551	41	187	155

SIZE	High Speed shaft							Low Speed shaft						
	d1	L1	L13	L14	t1	u1	w1	d	L	L11	L12	t	u	w
M0342	16 k6	40	4	32	18	5	M5 x 0.8 12 deep	25 k6	50	4	40	28	8	M10 x 1.5 22 deep
M0442	16 k6	40	4	32	18	5	M5 x 0.8 12 deep	30 k6	60	4	50	33	8	M10 x 1.5 22 deep
M0542	16 k6	40	4	32	18	5	M5 x 0.8 12 deep	35 k6	70	7	60	38	10	M12 x 1.75 28 deep
M0642	16 k6	40	4	32	18	5	M5 x 0.8 12 deep	35 k6	70	7	60	38	10	M12 x 1.75 28 deep
M0742	16 k6	40	4	32	18	5	M5 x 0.8 12 deep	40 k6	80	5	70	43	12	M16 x 2.0 36 deep
M0842	19 k6	40	4	32	21.5	6	M6 x 1.0 16 deep	50 k6	100	10	80	53.5	14	M16 x 2.0 36 deep
M0941	19 k6	40	4	32	21.5	6	M6 x 1.0 16 deep	60 m6	120	10	100	64	18	M20 x 2.5 42 deep
M1041	24 k6	50	5	40	27	8	M8 x 1.25 19 deep	70 m6	140	15	110	74.5	20	M20 x 2.5 42 deep
M1341	24 k6	50	5	40	27	8	M8 x 1.25 19 deep	90 m6	170	15	140	95	25	M24 x 3.0 50 deep
M1441	24 k6	50	5	40	27	8	M8 x 1.25 19 deep	100 m6	210	15	180	106	28	M24 x 3.0 50 deep

SERIES M

DIMENSIONS - QUINTUPLE REDUCTION BASE MOUNT

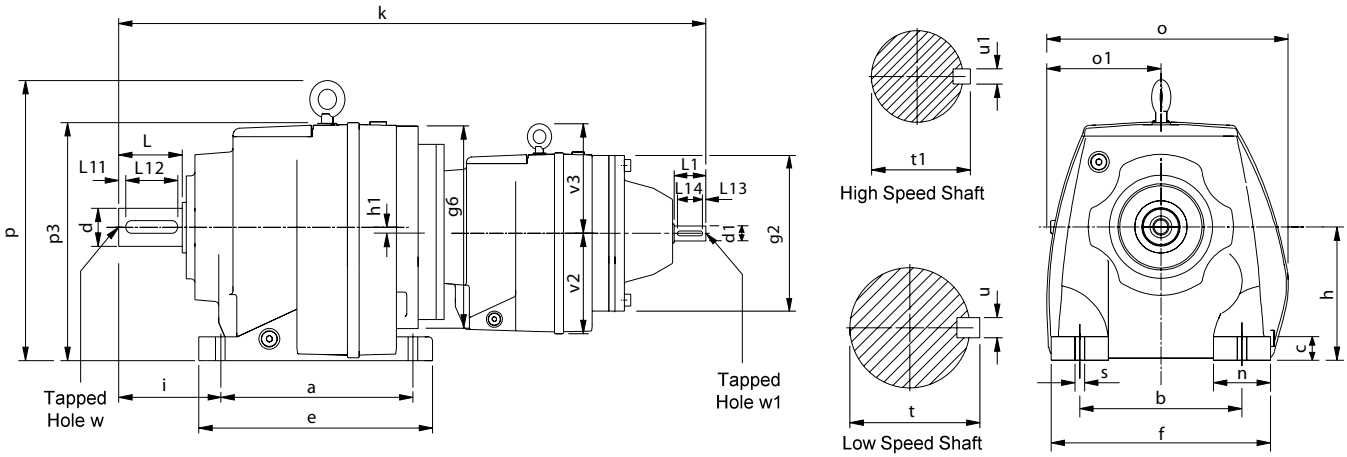

all parallel keys are to DIN 6885

size	a	b	c	e	f	g2	g6	h	h1	i	k	n	o	o1	p	p3	s	v2	v3
M0352	130	110	16	152	145	140	140	90	-	75	518	35	170	84	-	180	10	76	-
M0452	165	135	20	200	190	140	180	115	-	90	584	55	204	97	-	208	15	91	-
M0552	165	135	20	200	190	140	180	115	-	100	594	55	204	97	-	208	15	91	-
M0652	195	150	24	235	210	140	180	130	14.5	100	615	60	220	110	246	214	15	91	-
M0752	205	170	25	245	230	140	212	140	-	115	651	60	252	119	295	250	19	91	-
M0852	260	215	35	310	290	180	250	180	-	140	759	75	320	167	360	310	19	115	-
M0951	310	250	40	365	340	180	250	225	-	160	840	90	372	200	433	394	23	113	-
M1051	370	290	45	440	400	180	300	250	-	185	968	110	428	225	505	446	27	138	155
M1351	410	340	50	490	450	212	350	265	-	220	1089	110	470	242	563	483	34	187	155
M1451	500	380	50	590	530	212	350	300	-	260	1204	150	546	278	630	551	41	187	155

SIZE	High Speed shaft							Low Speed shaft						
	d1	L1	L13	L14	t1	u1	w1	d	L	L11	L12	t	u	w
M0352	16 k6	40	4	32	18	5	M5 x 0.8 12 deep	25 k6	50	4	40	28	8	M10 x 1.5 22 deep
M0452	16 k6	40	4	32	18	5	M5 x 0.8 12 deep	30 k6	60	4	50	33	8	M10 x 1.5 22 deep
M0552	16 k6	40	4	32	18	5	M5 x 0.8 12 deep	35 k6	70	7	60	38	10	M12 x 1.75 28 deep
M0652	16 k6	40	4	32	18	5	M5 x 0.8 12 deep	35 k6	70	7	60	38	10	M12 x 1.75 28 deep
M0752	16 k6	40	4	32	18	5	M5 x 0.8 12 deep	40 k6	80	5	70	43	12	M16 x 2.0 36 deep
M0852	16 k6	40	4	32	18	5	M5 x 0.8 12 deep	50 k6	100	10	80	53.5	14	M16 x 2.0 36 deep
M0951	16 k6	40	4	32	18	5	M5 x 0.8 12 deep	60 m6	120	10	100	64	18	M20 x 2.5 42 deep
M1051	19 k6	40	4	32	21.5	6	M6 x 1.0 16 deep	70 m6	140	15	110	74.5	20	M20 x 2.5 42 deep
M1351	19 k6	40	4	32	21.5	6	M6 x 1.0 16 deep	90 m6	170	15	140	95	25	M24 x 3.0 50 deep
M1451	19 k6	40	4	32	21.5	6	M6 x 1.0 16 deep	100 m6	210	15	180	106	28	M24 x 3.0 50 deep

SERIES M

DIMENSIONS - DOUBLE REDUCTION FLANGE MOUNT

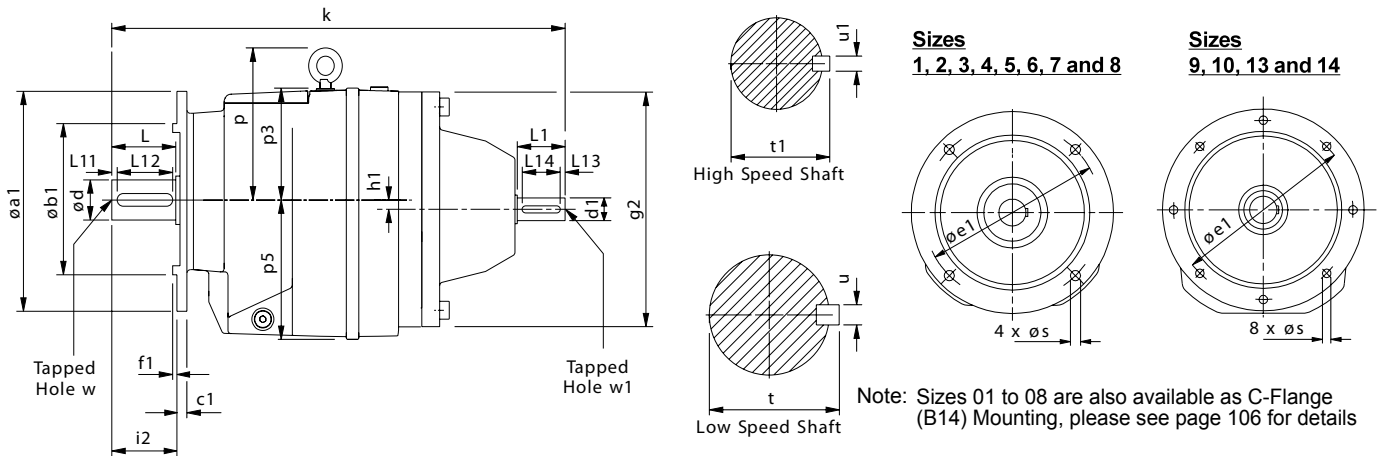

all parallel keys are to DIN 6885

Size	Øa1	Øb1	c1	Øe1	f1	Øg2	h1	i2	k	p	p3	p5	s
M0122	120	80	9	100	3	140	-	40	286	-	74	76	7
	140	95	9	115	3			40					9
	160	110	10	130	3.5			40					9
	200	130	10	165	3.5			40					11
M0222	120	80	10	100	3	140	-	50	317	-	90	91	6.6
	140	95	10	115	3			50					9
	160	110	10	130	3.5			50					9
	200	130	10	165	3.5			50					11
M0322	120	80	10	100	3	140	-	50	317	-	90	91	6.6
	140	95	10	115	3			50					9
	160	110	10	130	3.5			50					9
	200	130	10	165	3.5			50					11
M0422	140	95	11	115	3	180	-	60	369	-	93	115	9
	160	110	11	130	3.5			60					9
	200	130	11	165	3.5			60					11
	250	180	11	215	4			60					13.5
M0522	140	95	11	115	3	180	-	70	379	-	93	115	9
	160	110	11	130	3.5			70					9
	200	130	11	165	3.5			70					11
	250	180	11	215	4			70					13.5
M0622	200	130	11	165	4	180	14.5	70	400	116	84	130	11
	250	180	11	215	4			70					13.5
	300	230	11	265	4			70					13.5
M0722	200	130	11	165	3.5	212	-	80	440	155	110	140	11
	250	180	11	215	4			80					13.5
	300	230	11	265	4			80					13.5
M0822	300	230	17	265	4	250	-	100	55	180	130	182	13.5
	350	250	17	300	5			100					17.5
M0921	450	350	18	400	5	300	-	140	660	198	-	230	18
M1021	450	350	22	400	5	360	-	140	782	245	-	260	18
M1321	550	450	25	500	5	400	-	170	907	288	-	278	18
M1421	550	450	25	500	5	460	-	210	1022	320	-	318	18

SIZE	High Speed shaft							Low Speed shaft						
	d1	L1	L13	L14	t1	u1	w1	d	L	L11	L12	t	u	w1
M0122	16 k6	40	4	32	18	5	M5 x 0.8 12 deep	20 k6	40	4	32	22.5	6	M6 x 1.16 deep
M0222	16 k6	40	4	32	18	5	M5 x 0.8 12 deep	25 k6	50	4	40	28	8	M10 x 1.5 22 deep
M0322	16 k6	40	4	32	18	5	M5 x 0.8 12 deep	25 k6	50	4	40	28	8	M10 x 1.5 22 deep
M0422	19 k6	40	4	32	21.5	6	M6 x 1.0 16 deep	30 k6	60	4	50	33	8	M10 x 1.5 22 deep
M0522	19 k6	40	4	32	21.5	6	M6 x 1.0 16 deep	35 k6	70	7	60	38	10	M12 x 1.75 28 deep
M0622	19 k6	40	4	32	21.5	6	M6 x 1.0 16 deep	35 k6	70	7	60	38	10	M12 x 1.75 28 deep
M0722	24 k6	50	5	40	27	8	M8 x 1.25 19 deep	40 k6	80	5	70	43	12	M16 x 2.0 36 deep
M0822	28 k6	60	5	50	31	8	M10 x 1.5 22 deep	50 k6	100	10	80	53.5	14	M16 x 2.0 36 deep
M0921	38 k6	80	5	70	41	10	M12 x 1.75 28 deep	60 m6	120	10	100	64	18	M20 x 2.5 42 deep
M1021	42 k6	110	10	70	45	12	M16 x 2.0 36 deep	70 m6	140	15	110	74.5	20	M20 x 2.5 42 deep
M1321	55 m6	110	10	90	59	16	M20 x 2.5 42 deep	90 m6	170	15	140	95	25	M24 x 3.0 50 deep
M1421	55 m6	110	10	90	59	16	M20 x 2.5 42 deep	100 m6	210	15	180	106	28	M24 x 3.0 50 deep

SERIES M

DIMENSIONS - TRIPLE REDUCTION FLANGE MOUNT

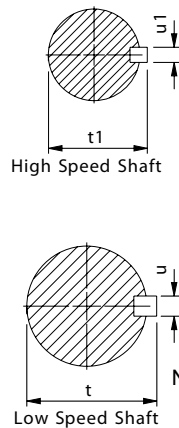
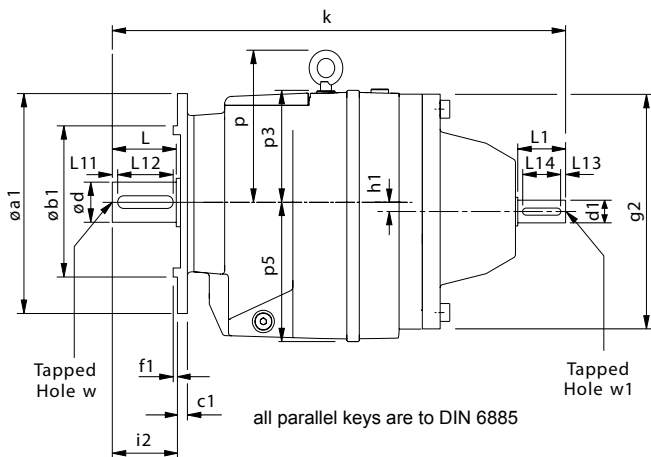

Sizes
1, 2, 3, 4, 5, 6, 7 and 8

Sizes
9, 10, 13 and 14

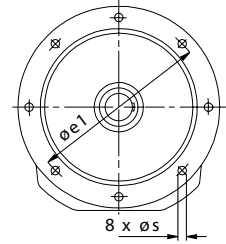
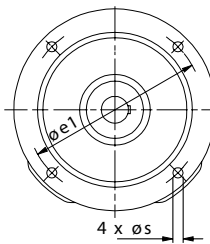

Note: Sizes 01 to 08 are also available as C-Flange (B14) Mounting, please see page 106 for details

Size	Øa1	Øb1	c1	Øe1	f1	Øg2	h1	i2	k	p	p3	p5	s
M0132	120	80	9	100	3	140	-	40	301	-	74	76	7
	140	95	9	115	3			40					9
	160	110	10	130	3.5			40					9
	200	130	10	165	3.5			40					11
M0232	120	80	10	100	3	140	-	50	330	-	90	91	6.6
	140	95	10	115	3			50					9
	160	110	10	130	3.5			50					9
	200	130	10	165	3.5			50					11
M0332	120	80	10	100	3	140	-	50	330	-	90	91	6.6
	140	95	10	115	3			50					9
	160	110	10	130	3.5			50					9
	200	130	10	165	3.5			50					11
M0432	140	95	11	115	3	180	-	60	377	-	93	115	9
	160	110	11	130	3.5			60					9
	200	130	11	165	3.5			60					11
	250	180	11	215	4			60					13.5
M0532	140	95	11	115	3	180	-	70	387	-	93	115	9
	160	110	11	130	3.5			70					9
	200	130	11	165	3.5			70					11
	250	180	11	215	4			70					13.5
M0632	200	130	11	165	4	180	14.5	70	408	116	84	130	11
	250	180	11	215	4			70					13.5
	300	230	11	265	4			70					13.5
M0732	200	130	11	165	3.5	212	-	80	452	155	110	140	11
	250	180	11	215	4			80					13.5
	300	230	11	265	4			80					13.5
M0832	300	230	17	265	4	250	-	100	540	180	130	182	13.5
	350	250	17	300	5			100					17.5
M0931	450	350	18	400	5	300	-	140	662	198	-	230	18
M1031	450	350	22	400	5	360	-	140	784	245	-	260	18
M1331	550	450	25	500	5	400	-	170	969	288	-	278	18
M1431	550	450	25	500	5	460	-	210	1094	320	-	318	18

Size	High Speed shaft						Low Speed shaft							
	d1	L1	L13	L14	t1	u1	d	L	L11	L12	t	u	w1	
M0132	16 k6	40	4	32	18	5	M5 x 0.8 12 deep	20 k6	40	4	32	22.5	6	M6 x 1 16 deep
M0232	16 k6	40	4	32	18	5	M5 x 0.8 12 deep	25 k6	50	4	40	28	8	M10 x 1.5 22 deep
M0332	16 k6	40	4	32	18	5	M5 x 0.8 12 deep	25 k6	50	4	40	28	8	M10 x 1.5 22 deep
M0432	16 k6	40	4	32	18	5	M5 x 0.8 12 deep	30 k6	60	4	50	33	8	M10 x 1.5 22 deep
M0532	16 k6	40	4	32	18	5	M5 x 0.8 12 deep	35 k6	70	7	60	38	10	M12 x 1.75 28 deep
M0632	16 k6	40	4	32	18	5	M5 x 0.8 12 deep	35 k6	70	7	60	38	10	M12 x 1.75 28 deep
M0732	19 k6	40	4	32	21.5	6	M6 x 1.0 19 deep	40 k6	80	5	70	43	12	M16 x 2.0 36 deep
M0832	24 k6	50	5	40	27	6	M8 x 1.25 22 deep	50 k6	100	10	80	53.5	14	M16 x 2.0 36 deep
M0931	28 k6	60	5	50	31	8	M10 x 1.5 28 deep	60 m6	120	10	100	64	18	M20 x 2.5 42 deep
M1031	38 k6	80	5	70	41	10	M12 x 1.75 36 deep	70 m6	140	15	110	74.5	20	M20 x 2.5 42 deep
M1331	55 m6	110	10	90	59	16	M20 x 2.5 42 deep	90 m6	170	15	140	95	25	M24 x 3.0 50 deep
M1431	55 m6	110	10	90	59	16	M20 x 2.5 42 deep	100 m6	210	15	180	106	28	M24 x 3.0 50 deep

SERIES M

DIMENSIONS - QUADRUPLE REDUCTION FLANGE MOUNT

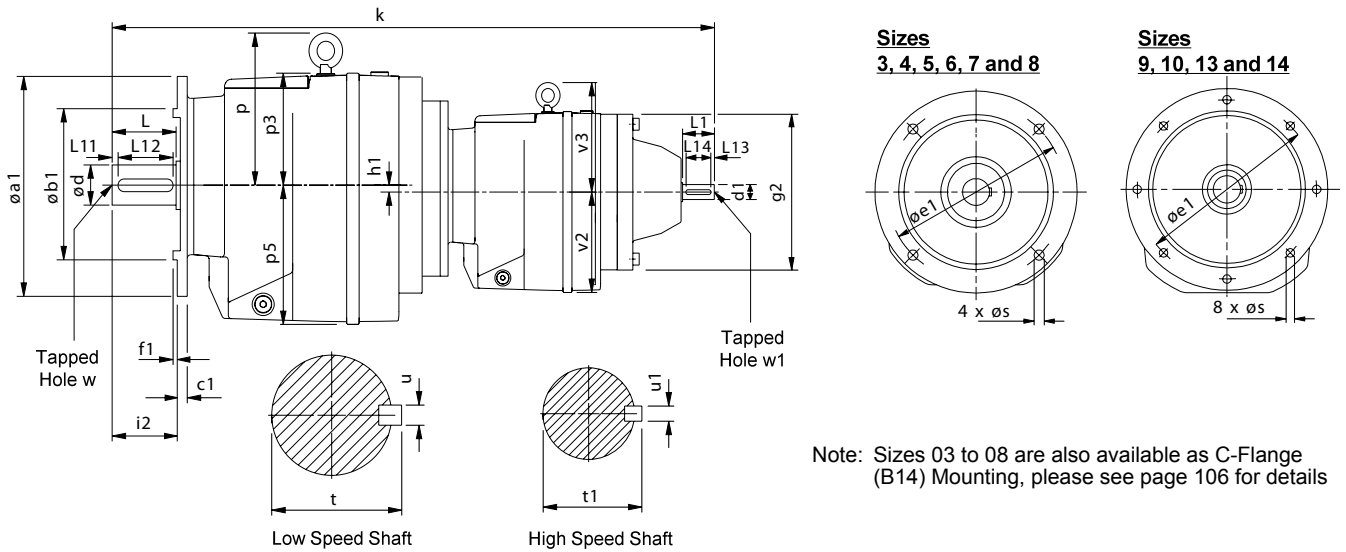

Sizes
3, 4, 5, 6, 7 and 8

Sizes
9, 10, 13 and 14

Note: Sizes 03 to 08 are also available as C-Flange (B14) Mounting, please see page 106 for details

all parallel keys are to DIN 6885

Size	$\varnothing a1$	$\varnothing b1$	c1	$\varnothing e1$	f1	$\varnothing g2$	h1	i2	k	p	p3	p5	s	v2	v3
M0342	120	80	10	100	3	140	-	50	503	-	90	91	6.6	76	-
	140	95	10	115	3			50					9		
	160	110	10	130	3.5			50					9		
	200	130	10	165	3.5			50					11		
M0442	140	95	11	115	3	140	-	60	571	-	93	115	9	91	-
	160	110	11	130	3.5			60					9		
	200	130	11	165	3.5			60					11		
	250	180	11	215	4			60					13.5		
M0542	140	95	11	115	3	140	-	70	581	-	93	115	9	91	-
	160	110	11	130	3.5			70					9		
	200	130	11	165	3.5			70					11		
	250	180	11	215	4			70					13.5		
M0642	200	130	11	165	4	140	14.5	70	602	116	84	130	11	91	-
	250	180	11	215	4			70					13.5		
	300	230	11	265	4			70					13.5		
M0742	200	130	11	165	3.5	140	-	80	639	155	110	140	11	91	-
	250	180	11	215	4			80					13.5		
	300	230	11	265	4			80					13.5		
M0842	300	230	17	265	4	180	-	100	751	180	130	182	13.5	115	-
	350	250	17	300	5			100					17.5		
M0941	450	350	18	400	5	180	-	140	832	198	-	230	18	115	-
M1041	450	350	22	400	5	212	-	140	956	245	-	260	18	140	155
M1341	550	450	25	500	5	212	-	170	1077	288	-	278	18	140	155
M1441	550	450	25	500	5	212	-	210	1192	320	-	318	18	140	155

Size	High Speed shaft							Low Speed shaft						
	d1	L1	L13	L14	t1	u1	w1	d	L	L11	L12	t	u	w1
M0342	16 k6	40	4	32	18	5	M5 x 0.8 12 deep	25 k6	50	4	40	28	8	M10 x 1.5 22 deep
M0442	16 k6	40	4	32	18	5	M5 x 0.8 12 deep	30 k6	60	4	50	33	8	M10 x 1.5 22 deep
M0542	16 k6	40	4	32	18	5	M5 x 0.8 12 deep	35 k6	70	7	60	38	10	M12 x 1.75 28 deep
M0642	16 k6	40	4	32	18	5	M5 x 0.8 12 deep	35 k6	70	7	60	38	10	M12 x 1.75 28 deep
M0742	16 k6	40	4	32	18	5	M5 x 0.8 12 deep	40 k6	80	5	70	43	12	M16 x 2.0 36 deep
M0842	19 k6	40	4	32	21.5	6	M6 x 1.0 16 deep	50 k6	100	10	80	53.5	14	M16 x 2.0 36 deep
M0941	19 k6	40	4	32	21.5	6	M6 x 1.0 16 deep	60 m6	120	10	100	64	18	M20 x 2.5 42 deep
M1041	24 k6	50	5	40	27	8	M8 x 1.25 19 deep	70 m6	140	15	110	74.5	20	M20 x 2.5 42 deep
M1341	24 k6	50	5	40	27	8	M8 x 1.25 19 deep	90 m6	170	15	140	95	25	M24 x 3.0 50 deep
M1441	24 k6	50	5	40	27	8	M8 x 1.25 19 deep	100 m6	210	15	180	106	28	M24 x 3.0 50 deep

SERIES M

DIMENSIONS - QUINTUPLE REDUCTION FLANGE MOUNT

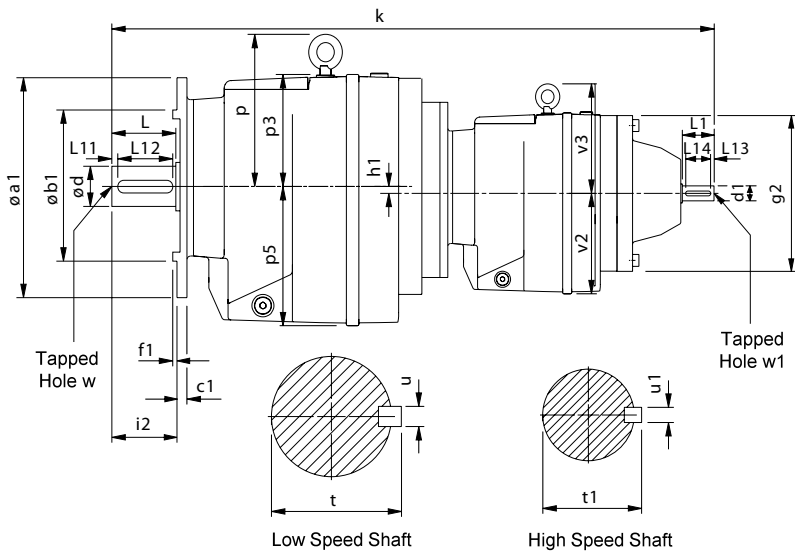

Sizes
3, 4, 5, 6, 7 and 8

Sizes
9, 10, 13 and 14

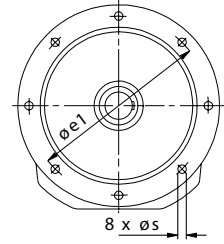
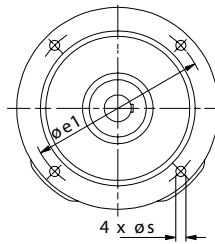

Note: Sizes 03 to 08 are also available as C-Flange (B14) Mounting, please see page 106 for details

all parallel keys are to DIN 6885

Size	Øa1	Øb1	c1	Øe1	f1	Øg2	h1	i2	k	p	p3	p5	s	v2	v3
M0352	120	80	10	100	3	140	-	50	518	-	90	91	6.6	76	-
	140	95	10	115	3			50					9		
	160	110	10	130	3.5			50					9		
	200	130	10	165	3.5			50					11		
M0452	140	95	11	115	3	140	-	60	584	-	93	115	9	91	-
	160	110	11	130	3.5			60					9		
	200	130	11	165	3.5			60					11		
	250	180	11	215	4			60					13.5		
M0552	140	95	11	115	3	140	-	70	594	-	93	115	9	91	-
	160	110	11	130	3.5			70					9		
	200	130	11	165	3.5			70					11		
	250	180	11	215	4			70					13.5		
M0652	200	130	11	165	4	140	14.5	70	615	116	84	130	11	91	-
	250	180	11	215	4			70					13.5		
	300	230	11	265	4			70					13.5		
M0752	200	130	11	165	3.5	140	-	80	651	155	110	140	11	91	-
	250	180	11	215	4			80					13.5		
	300	230	11	265	4			80					13.5		
M0852	300	230	17	265	4	180	-	100	759	180	130	182	13.5	115	-
	350	250	17	300	5			100					17.5		
M0951	450	350	18	400	5	180	-	140	840	198	-	230	18	115	-
M1051	450	350	22	400	5	212	-	140	968	245	-	260	18	140	155
M1351	550	450	25	500	5	212	-	170	1089	288	-	278	18	140	155
M1451	550	450	25	500	5	212	-	210	1204	320	-	318	18	140	155

Size	High Speed shaft							Low Speed shaft						
	d1	L1	L13	L14	t1	u1	w1	d	L	L11	L12	t	u	w1
M0352	16 k6	40	4	32	18	5	M5 x 0.8 12 deep	25 k6	50	4	40	28	8	M10 x 1.5 22 deep
M0452	16 k6	40	4	32	18	5	M5 x 0.8 12 deep	30 k6	60	4	50	33	8	M10 x 1.5 22 deep
M0552	16 k6	40	4	32	18	5	M5 x 0.8 12 deep	35 k6	70	7	60	38	10	M12 x 1.75 28 deep
M0652	16 k6	40	4	32	18	5	M5 x 0.8 12 deep	35 k6	70	7	60	38	10	M12 x 1.75 28 deep
M0752	16 k6	40	4	32	18	5	M5 x 0.8 12 deep	40 k6	80	5	70	43	12	M16 x 2.0 36 deep
M0852	16 k6	40	4	32	18	5	M5 x 0.8 12 deep	50 k6	100	10	80	53.5	14	M16 x 2.0 36 deep
M0951	16 k6	40	4	32	18	5	M5 x 0.8 12 deep	60 m6	120	10	100	64	18	M20 x 2.5 42 deep
M1051	19 k6	40	4	32	21.5	6	M6 x 1.0 16 deep	70 m6	140	15	110	74.5	20	M20 x 2.5 42 deep
M1351	19 k6	40	4	32	21.5	6	M6 x 1.0 16 deep	90 m6	170	15	140	95	25	M24 x 3.0 50 deep
M1451	19 k6	40	4	32	21.5	6	M6 x 1.0 16 deep	100 m6	210	15	180	106	28	M24 x 3.0 50 deep

SERIES M

DIMENSIONS - C-FLANGE (B14) MOUNTING

Column 9 Entry

- E C-Flange (B14) Mounting (For sizes M01 to M08 only)
- V Base and C-Flange (B14) Mounting (non standard - special orders only)

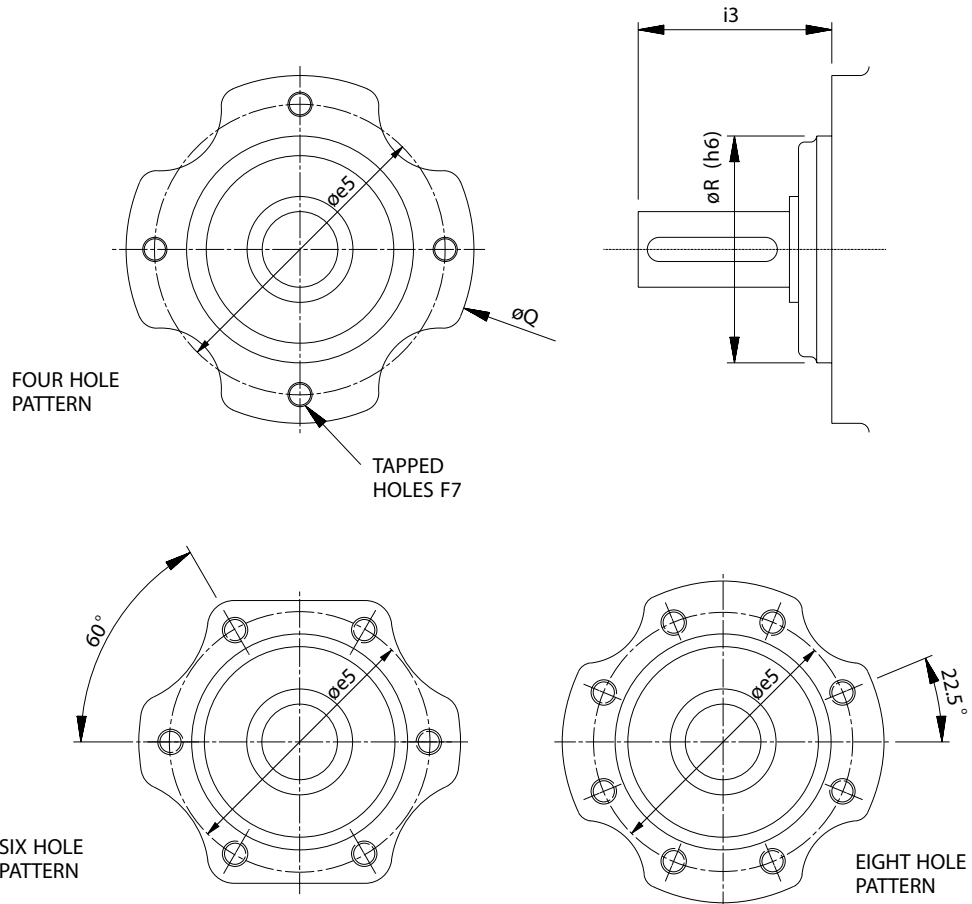

2, 3, 4 & 5 Stage Units

SIZE	Øe5	F7	i3	ØQ	ØR
M01	75 pcd	4 Holes M8 x 1.25 12 Deep	54	98	52
M02 / M03	96 pcd	4 Holes M8 x 1.25 15 Deep	62 / 62	115	75
M04 / M05	105 pcd	4 Holes M12 x 1.75 21 Deep	74 / 84	130	85
M06 / M07	124 pcd	6 Holes M12 x 1.75 21 Deep	84 / 94	152	102
M08	170 pcd	8 Holes M12 x 1.75 21 Deep	120	195	145

SERIES M

THERMAL POWER RATINGS

Thermal Ratings kW

Thermal ratings are a measure of the units ability to dissipate heat, if they are exceeded the lubricant may break down resulting in premature gear failure.

Thermal rating are based on an ambient temperature of 20°C, where units are to operate in other ambient temperatures thermal ratings must be adjusted by the following factors

Unit Size								
	-20	-10	0	10	20	30	40	50
All Units	1.57	1.43	1.29	1.14	1.00	0.86	0.71	0.5

Thermal Power (kW) - Two Stage Units

Overall Ratios	Type Of Cooling	Input rev/min	Unit Size											
			M01	M02	M03	M04	M05	M06	M07	M08	M09	M10	M13	M14
1.4 to 5.6	Units with no additional cooling	2900	Consult Application Engineering											
		1450	4.1	6	6	9.9	9.9	11.5	14.5	22	31	42	54	73
		960	4	5.7	5.7	9.5	9.5	11	13.8	21	30	40	51	70
		725	3.9	5.6	5.6	9.2	9.2	10.6	13.4	20	29	39	50	68
6.3 & over	Units with no additional cooling	2900	3	4.4	4.4	7.2	7.2	8.3	10.5	16	23	31	39	53
		1450	4.1	5.8	5.8	9.8	9.8	11.3	14.2	22	31	42	53	72
		960	3.9	5.5	5.5	9.4	9.4	10.8	13.6	21	29	40	50	69
		725	3.8	5.4	5.4	9.1	9.1	10.5	13.1	20	28	38	49	67
1.4 to 5.6	Units with Fan cooling	2900	N/A	N/A	N/A	N/A	N/A	N/A	N/A	N/A	N/A	N/A	N/A	N/A
		1450	-	-	-	-	-	-	29	44	63	85	107	146
		960	-	-	-	-	-	-	25	39	55	74	94	128
		725	-	-	-	-	-	-	22	33	47	63	81	110
6.3 & over	Units with Fan cooling	2900	-	-	-	-	-	-	N/A	N/A	N/A	N/A	N/A	N/A
		1450	-	-	-	-	-	-	28	43	62	83	105	144
		960	-	-	-	-	-	-	25	38	54	73	92	126
		725	-	-	-	-	-	-	21	33	46	62	79	108

Note: When checking thermal capacities use actual load required to be transmitted, not rating of prime mover.

SERIES M

FAN COOLED UNITS

Column 10 Entry

For reducer fan kit modules enter **S** in column 10

or if used in conjunction with a reducer backstop module kit

Y

CW rotation

Z

CCW rotation

Dimensions of Fan Cooled Units

Double Reduction Units

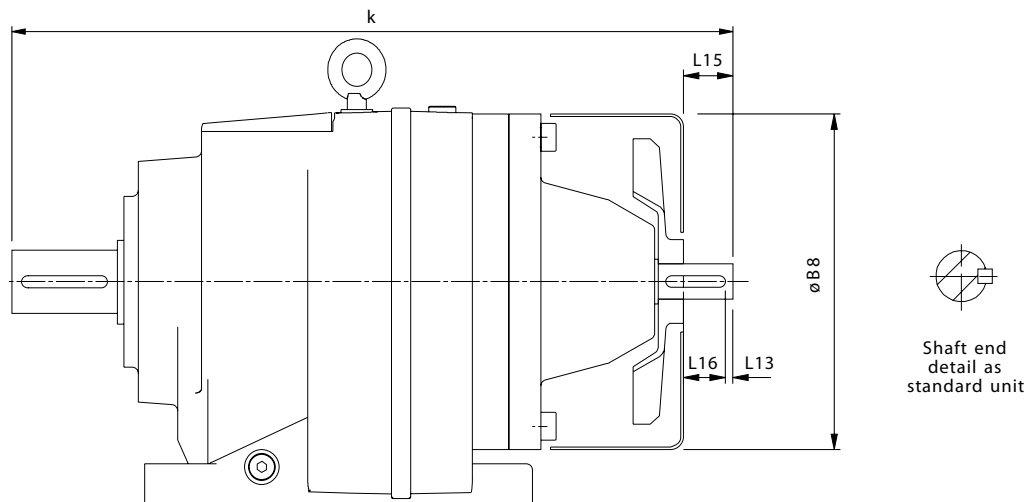

Unit Size	ØB8	k	L13	L15	L16
M0722	225	440	5	35	30
M0822	265	555	5	45	40
M0921	320	660	5	65	60
M1021	380	782	10	95	85
M1321	420	907	10	85	75
M1421	480	1022	10	85	75

SERIES M

REDUCER BACKSTOP MODULE

The reducer units listed below can be fitted with an internal backstop, this has no effect of the external unit size. The backstop device incorporates high quality centrifugal lift off sprags which are wear free above the lift off speed (n min). To ensure correct operation input speed must exceed lift off speed.

Suitable for ambient temperature -40°C to + 50°C

Column 10 Entry

For reducer backstop modules enter W for CCW rotation (or Z if used in conjunction with a fan kit)
 X for CW rotation (or Y if used in conjunction with a fan kit)

Unit Size	Lift off Speed ('n' min) (at inputshaft) (rev/min)	Rated Locking Torque ('T max') (at inputshaft) (Nm)
M0422	800	100
M0522	800	100
M0622	800	100
M0712	670	170
M0722	670	170
M0732	800	100
M0822	670	300
M0832	670	170
M0921	620	940
M0931	670	300
M1021	550	1260
M1031	670	300
M1321	550	2400
M1331	550	2400
M1421	550	2400
M1431	550	2400

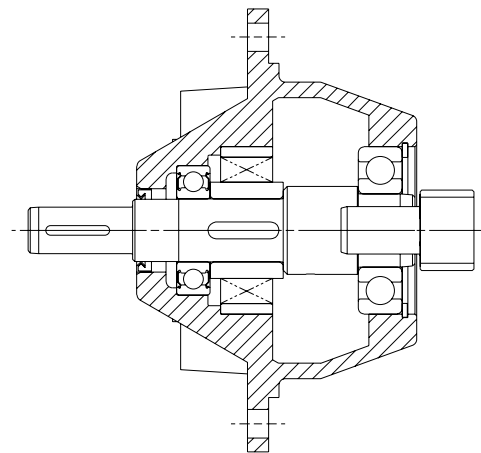

Rotation of outputshaft must be specified when ordering as viewed from the outputshaft end (as shown in the diagram)

CW - Free Rotation - Clockwise
 Locked - Anticlockwise

AC - Free Rotation - Anticlockwise
 Locked - Clockwise

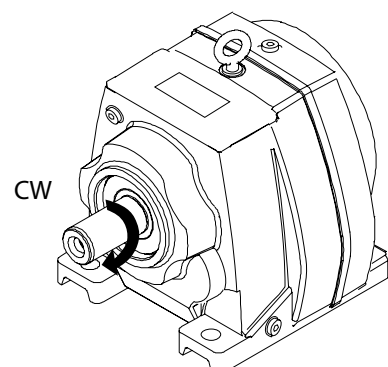

SERIES M

SHIPPING SPECIFICATION

BASE MOUNT UNITS

UNIT SIZE & No OF REDUCTIONS		M0122	M0132	M0222	M0232	M0322	M0332	M0342	M0352	M0422	M0432	M0442	M0452	M0522	M0532	M0542	M0552	M0622	M0632	M0642	M0652	M0722	
REDUCER VERSION		8.2	8.8	12	13	12	13	21.1	21.7	22	22	33	34	22	22	35	36	27	27	40	41	38	
MOTORISED	63	Without Motor	8.9	11	12	14	12	14	22	23		24	36	37		24	36	37		29	41	43	
		With Motor	13	15	17	18	17	18	26	28		28	40	42		28	40	42		33	45	47	
	71	Without Motor	8.5	10	12	14	12	14	21	23		23	35	37		23	35	37		29	41	42	
		With Motor	15	17	19	20	19	20	28	29		30	42	43		30	42	44		35	47	49	
	80A	Without Motor	9.0	12	13	14	13	14	22	23	21	24	36	37	22	24	36	38	27	29	41	43	34
		With Motor	19	21	22	24	22	24	31	33	31	33	45	47	31	33	45	47	36	39	51	52	44
	80B	Without Motor	9.0	12	13	14	13	14	22	23	21	24	36	37	22	24	36	38	27	29	41	43	34
		With Motor	20	23	24	25	24	25	33	34	32	35	47	48	33	35	47	49	38	40	52	54	45
	90S	Without Motor	10	12	13	16	13	15	23	24	22	24	37	38	23	25	37	38	28	30	42	44	35
		With Motor	23	25	27	30	27	28	36	38	36	38	50	52	36	38	50	52	41	43	55	57	48
	90L	Without Motor	10	12	13	16	13	15	23	24	22	24	37	38	23	25	37	38	28	30	42	44	35
		With Motor	24	26	28	31	28	29	37	39	37	39	51	53	37	39	51	53	42	44	56	58	49
	100L	Without Motor	12		15		15				25				25				31				38
		With Motor	36		39		39				49				51				54				62
	112M	Without Motor	12		15		15				25				25				31				38
		With Motor	43		46		46				56				56				62				69
	132S	Without Motor																					40
		With Motor																					88
	132M	Without Motor																					40
		With Motor																					92
	160M	Without Motor																					
		With Motor																					
	160L	Without Motor																					
		With Motor																					

ALL WEIGHTS IN KG

ALL WEIGHTS EXCLUDE LUBRICANT

SERIES M

SHIPPING SPECIFICATION

BASE MOUNT UNITS

UNIT SIZE & No OF REDUCTIONS		M0732	M0742	M0752	M0822	M0832	M0842	M0852	M0921	M0931	M0941	M0951	M1021	M1031	M1041	M1051	M1321	M1331	M1341	M1351	M1421	M1431	M1441	M1451	
REDUCER VERSION		39	48	49	67	74	96	96	114	123	140	140	170	179	204	206	248	270	279	280	360	405	395	396	
MOTORISED	80A	Without Motor	39	48	52	73	71	96	99	117	127	145	148		182	194	199			336	342			446	452
		With Motor	49	57	61	82	81	106	108	127	137	154	157		192	203	209			346	351			456	461
	80B	Without Motor	39	48	52	73	71	96	99	117	127	145	148		182	194	199			336	342			446	452
		With Motor	50	59	63	84	82	107	110	128	138	156	159		193	205	210			347	353			457	463
	90S	Without Motor	40	48	52	73	72	97	100	117	127	145	149		182	194	200			337	342			445	450
		With Motor	53	62	66	86	85	110	113	131	141	159	162		196	208	213			350	356			458	464
	90L	Without Motor	40	48	52	73	72	97	100	117	127	145	149		182	194	200			337	342			445	450
		With Motor	54	63	67	87	86	111	114	132	142	160	163		197	209	214			351	357			459	465
	100L	Without Motor	39			73	75	97		117	127	145		163	182	197	203	239	271	340	345	344	394	450	455
		With Motor	63			97	99	121		141	151	169		187	206	221	227	263	295	364	369	368	418	474	479
	112M	Without Motor	43			73	75			117	127			163	182	197	203	239	271	340	345	344	394	450	455
		With Motor	74			104	106			148	158			194	213	228	234	270	302	371	376	375	425	481	486
	132S	Without Motor				72				117				163	182	199		239	271	342	347	344	394	452	
		With Motor				120				165				211	230	247		287	319	390	395	392	442	500	
	132M	Without Motor				72				117				163	182	199		239	271	342	347	344	394	452	
		With Motor				124				169				215	234	251		291	323	394	399	396	446	504	
	160M	Without Motor				72				124				172	189			247	279			357	402		
		With Motor				153				205				253	270			328	360			438	483		
	160L	Without Motor				72				124				172	189			247	279			357	402		
		With Motor				167				219				267	284			342	374			452	497		
	180M	Without Motor								124				172	189			247	279			357	402		
		With Motor								291				339	356			414	446			524	569		
	180L	Without Motor								124				172	189			247	279			357	402		
		With Motor								305				353	370			428	460			538	583		
	200L	Without Motor								124				172				247	279			357	402		
		With Motor								356				404				479	511			589	634		
	225S	Without Motor								138				186				261	293			371	416		
		With Motor								425				473				548	580			658	703		
	225M	Without Motor								138				186				261	293			371	416		
		With Motor								460				508				583	615			693	738		
	250M	Without Motor																310				420			
		With Motor																695				805			
	280S	Without Motor																310				420			
		With Motor																820				930			
	280M	Without Motor																310				420			
		With Motor																910				1020			

ALL WEIGHTS IN KG

ALL WEIGHTS EXCLUDE LUBRICANT

IMPORTANT

Product Safety Information

General - The following information is important in ensuring safety. It **must** be brought to the attention of personnel involved in the selection of the equipment, those responsible for the design of the machinery in which it is to be incorporated and those involved in its installation, use and maintenance.

The equipment will operate safely provided it is selected, installed, used and maintained properly. As with any power transmission equipment **proper precautions must** be taken as indicated in the following paragraphs, to ensure safety.

Potential Hazards - these are **not** necessarily listed in any order of severity as the degree of danger varies in individual circumstances. It is important therefore that the list is studied in its entirety:-

- 1) Fire/Explosion
 - (a) Oil mists and vapour are generated within gear units. It is therefore dangerous to use naked lights in the proximity of gearbox openings, due to the risk of fire or explosion.
 - (b) In the event of fire or serious overheating (over 300 °C), certain materials (rubber, plastics, etc.) may decompose and produce fumes. Care should be taken to avoid exposure to the fumes, and the remains of burned or overheated plastic/rubber materials should be handled with rubber gloves.
- 2) Guards - Rotating shafts and couplings must be guarded to eliminate the possibility of physical contact or entanglement of clothing. It should be of rigid construction and firmly secured.
- 3) Noise - High speed gearboxes and gearbox driven machinery may produce noise levels which are damaging to the hearing with prolonged exposure. Ear defenders should be provided for personnel in these circumstances. Reference should be made to the Department of Employment Code of Practice for reducing exposure of employed persons to noise.
- 4) Lifting - Where provided (on larger units) only the lifting points or eyebolts must be used for lifting operations (see maintenance manual or general arrangement drawing for lifting point positions). Failure to use the lifting points provided may result in personal injury and/or damage to the product or surrounding equipment. Keep clear of raised equipment.
- 5) Lubricants and Lubrication
 - (a) Prolonged contact with lubricants can be detrimental to the skin. The manufacturer's instruction must be followed when handling lubricants.
 - (b) The lubrication status of the equipment must be checked before commissioning. Read and carry out all instructions on the lubricant plate and in the installation and maintenance literature. Heed all warning tags. Failure to do so could result in mechanical damage and in extreme cases risk of injury to personnel.
- 6) Electrical Equipment - Observe hazard warnings on electrical equipment and isolate power before working on the gearbox or associated equipment, in order to prevent the machinery being started.
- 7) Installation, Maintenance and Storage
 - (a) In the event that equipment is to be held in storage, for a period exceeding 6 months, prior to installation or commissioning, application engineering must be consulted regarding special preservation requirements. Unless otherwise agreed, equipment must be stored in a building protected from extremes of temperature and humidity to prevent deterioration.

The rotating components (gears and shafts) must be turned a few revolutions once a month (to prevent bearings brinelling).
 - (b) External gearbox components may be supplied with preservative materials applied, in the form of a "waxed" tape overwrap or wax film preservative. Gloves should be worn when removing these materials. The former can be removed manually, the latter using white spirit as a solvent.

Preservatives applied to the internal parts of the gear units do not require removal prior to operation.
 - (c) Installation must be performed in accordance with the manufacturer's instructions and be undertaken by suitably qualified personnel.
 - (d) Before working on a gearbox or associated equipment, ensure that the load has been removed from the system to eliminate the possibility of any movement of the machinery and isolate power supply. Where necessary, provide mechanical means to ensure the machinery cannot move or rotate. Ensure removal of such devices after work is complete.
 - (e) Ensure the proper maintenance of gearboxes in operation. Use only the correct tools and approved spare parts for repair and maintenance. Consult the Maintenance Manual before dismantling or performing maintenance work.
- 8) Hot Surfaces and Lubricants
 - (a) During operation, gear units may become sufficiently hot to cause skin burns. Care must be taken to avoid accidental contact.
 - (b) After extended running the lubricant in gear units and lubrication systems may reach temperatures sufficient to cause burns. Allow equipment to cool before servicing or performing adjustments.
- 9) Selection and Design
 - (a) Where gear units provide a backstop facility, ensure that back-up systems are provided if failure of the backstop device would endanger personnel or result in damage.
 - (b) The driving and driven equipment must be correctly selected to ensure that the complete machinery installation will perform satisfactorily, avoiding system critical speeds, system torsional vibration, etc.
 - (c) The equipment must not be operated in an environment or at speeds, powers, torques or with external loads beyond those for which it was designed.
 - (d) As improvements in design are being made continually the contents of this catalogue are not to be regarded as binding in detail, and drawings and capacities are subject to alterations without notice.

The above guidance is based on the current state of knowledge and our best assessment of the potential hazards in the operation of the gear units.

Any further information or clarification required may be obtained by contacting an Application Engineer.

CONTACT US

AUSTRALIA

**Radicon Transmission
(Australia) PTY Ltd**
Australia

Tel: +61 488 054 028

EUROPE

Benzler TBA BV

Jachthavenweg 2
NL-5928 NT Venlo

Austria

Tel: +43 7 229 618 91

Fax: +43 7 229 618 84

France

Tel: +33 687 718 711

Fax: +31 77 324 59 01

Germany

Tel: 0800 350 40 00

Fax: 0800 350 40 01

Italy

Tel: +39 02 824 3511

Netherlands & the rest of Europe

Tel: +31 77 324 59 00

Fax: +31 77 324 59 01

DENMARK

Benzler Transmission A/S

Fuglebævej 3D
DK-2770 Kastrup,
Denmark

Tel: +45 36 34 03 00

Fax: +45 36 77 02 42

FINLAND

Oy Benzler AB

Vanha Talvitie 3C
FI-00580 Helsingfors,
Finland

Tel: +358 9 340 1716

Fax: +358 10 296 2072

INDIA

Elecon. Engineering Company Ltd.

Anand Sojitra Road
Vallabh Vidyanagar
388120 Gujarat
India

Tel: +91 2692 236513

Fax: +91 2692 227484

SWEDEN & NORWAY

AB Benzlers

Box 922 (Landskronavägen 1)
251 09 Helsingborg
Sweden

Tel: +46 42 18 68 00

Fax: +46 42 21 88 03

THAILAND

Radicon Transmission (Thailand) Ltd

700/43 Moo 6
Amata Nakorn Industrial Estate
Tumbol Klongtumru
Muang,
Chonburi
20000
Thailand

Tel: +66 3845 9044

Fax: +66 3821 3655

UNITED KINGDOM

Radicon Transmission UK Ltd

Unit J3
Lowfields Business Park,
Lowfields Way, Elland
West Yorkshire, HX5 9DA

Tel: +44 (0) 1484 465 800

Fax: +44 (0) 1484 465 801

USA

Radicon USA Transmission Ltd

1599 Lunt Avenue
Elk Grove Village
Chicago
Illinois
60007
USA

Tel: +1 847 593 9910

Fax: +1 847 593 9950

www.benzlers.com

www.radicon.com

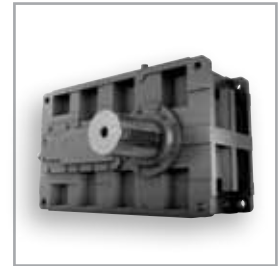
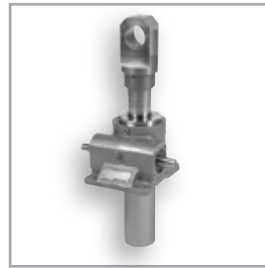

benzlers^{⚙️}
radicon^{⚙️}

Benzlers

Denmark +45 36 34 03 00
Finland +358 9 340 1716
Germany +49 800-350 4000
Italy +39 02 824 3511
Sweden +46 42 186800
The Netherlands +31 77 324 59 00
www.benzlers.com

Radicon

Thailand +66 3845 9044
United Kingdom +44 (0) 1484 465 800
USA +1 847 593 9910
www.radicon.com